

USER MANUAL

MERACH MR-S19 RECUMBENT BIKE

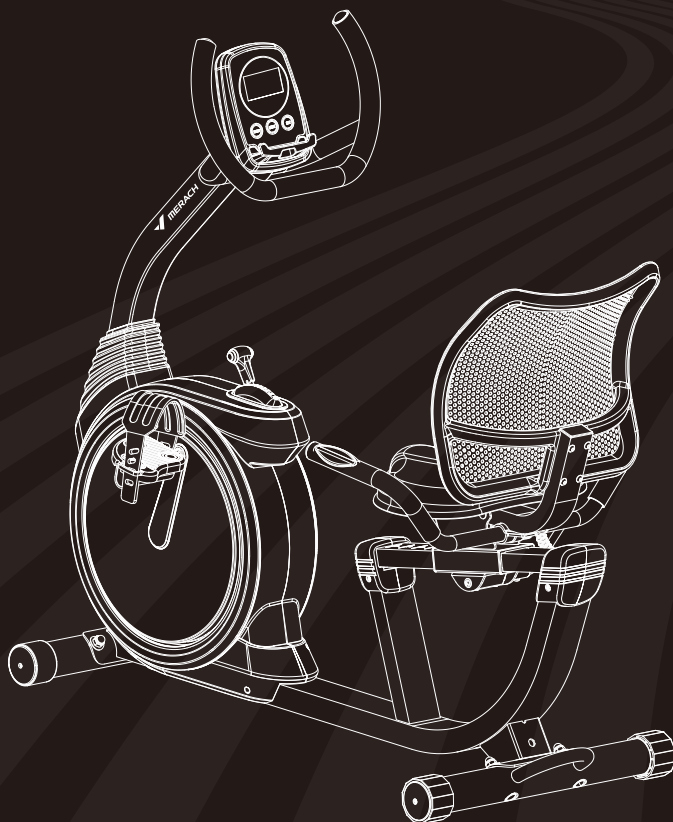

Questions or Concerns?

IMPORTANT!

Please read all details before use, and keep this user manual for future reference.
PLEASE CONTACT US BEFORE THE RETURN: Mon-Fri,9:00 am-5:00 pm PST/PDT
support@merach.com



WHO WE ARE



Our customers aren't just important; their health, fitness, and pure enjoyment for life is at the core of everything we do at MERACH. From innovative fitness research and cutting-edge product development, to our exceptional purchasing & after-sales service, we are our customers' life-long partner in crafting a better fitness future.

Through quality fat-burning & muscle-building fitness equipment such as our quality rowing machines and exercise bikes, plus our innovative MERACH APP, and digital courses, we give the opportunity and support to all to pursue their health and fitness goals and discover a new way of healthy living.

Welcome to MERACH

Contents

Safety Instructions.....	01
Parts List.....	03
Parts Tool List.....	04
Assembly Instructions.....	05
Product Usage Instructions.....	13
Instructions for the Monitor.....	16
Technical Details.....	19
MERACH APP SETUP.....	20
Warm-up.....	21
Troubleshooting.....	22
Warranty Information.....	23

This device contains a radio transmitter module with type approval code
FCC ID: 2A6QWMMR-BLE001 IC: 29678- MRBLE001 HVIN: MRBLE001



Please read the entire manual carefully
before installing and using the bike, and
save for further use.

Safety Instructions

Please keep this manual in a safe place for future reference.

- It is very important to read the entire manual thoroughly before installing and using the machine. Safe and effective training can only be achieved if the machine is properly assembled, properly maintained and used. Make sure all users are familiar with all warnings and precautions of this machine.
- Please consult your physician to determine if you have any medical or physical conditions that could put your health and safety at risk or prevent you from using the equipment properly. Your physician's advice is essential if you are taking medication that affects your heart rate, blood pressure, or cholesterol level.
- Please always pay attention to your body signals, improper use of the machine may affect your health. If you experience any symptoms (including headache, chest pain, irregular heartbeat, shortness of breath, dizziness, or any discomfort), stop exercising immediately and consult your physician, get the permission before training again.
- Always keep children and pets away from the machine. The machine is for adult use only.
- Please use this machine on stable and horizontal ground level, and put a protective layer on the floor or carpet to prevent a floor from damaging. Make sure the distance between the machine and each obstacle is at least 1.6 ft (0.5m).
- Please check all screws and nuts are properly tightened before using the machine.
- The safe use of the machine can only be guaranteed if the regular maintenance and repairs of undertaken, and worn out and broken parts are changed.
- Please follow the instructions in this manual to use this machine. Please stop using and operating immediately when you find any defective parts or hear any abnormal sound. Make sure all issues are resolved before using it again.
- Please wear sports clothes, sports shoes, or other proper clothes. Loose-fitting clothing is not recommended, as loose clothing may get caught in the machine, hindering operation and possibly causing an injury.
- This machine is only for home use. The maximum user weight is 330lbs.

Safety Instructions

- This machine is not for professional medical treatment.
- This product is only for family use.
- The overall performance of the machine and all moving parts must be checked regularly to ensure the safety of the machine.
- If the moving parts are damaged, please do not use the machine until the parts are repaired.
- Keep the children away from the machine. The equipment is not for children to use or play with. They can injure themselves accidentally.







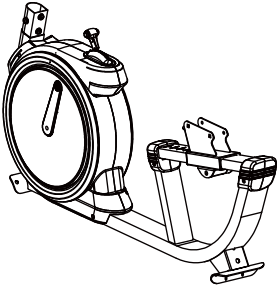
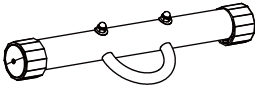
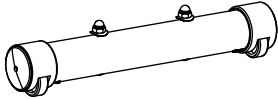
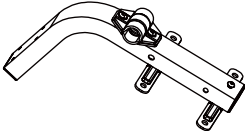

Care & Maintenance

- Do not store the machine in a place exposed to direct sunlight, wind and rain, or with high humidity. If needed, please pack the machine to keep children away from touching or playing with it.
- Please check if there's rust or cracks after long-term storage.
- Please understand that for the consumable parts, the wear and tear may also occur even with proper maintenance.
- For long-term use of this machine, please wipe the dust regularly. Do not water it directly, or wipe with gasoline, abrasive powder, etc. Otherwise, it might cause cracks on the parts or main body, electric shock or fire. Please use Dilute neutral detergent for maintenance.

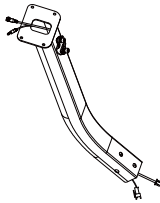
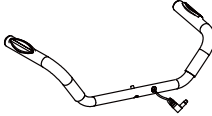

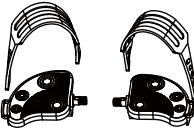
Before starting any training, please consult your physician, especially for those who are over 35 years old or with pre-existing health conditions. Please read all instructions before using the machine.

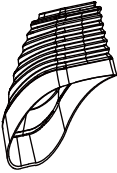
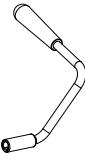
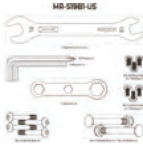
Parts List

 <p>#8 Main Frame X 1</p>	 <p>#22 Rear Foot Tube X 1</p>	 <p>#21 Front Foot Tube X 1</p>	
	 <p>#18 Backrest Support X 1</p>	 <p>#10 Seat Cushion X 1</p>	
 <p>#9 Handrail X 1</p>	 <p>#5 Handlebar Post X 1</p>	 <p>#15 Rear Handle X 1</p>	 <p>#26 Backrest X 1</p>
 <p>#4 Handlebar Cap X 1</p>	 <p>#20R Right Pedal X 1 #20L Left Pedal X 1</p>	 <p>#1 Monitor X 1 AA Battery X 2</p>	 <p>#27 Bottle Cage X 1</p>
 <p>#7 Decorative Cover X 1</p>	 <p>#25 Seat Cushion Adjustment Lever X 1</p>	 <p>Screw kit x1</p>	 <p>User Manual X 1</p>

Parts Tool List

Please check if all the parts and tools are in the package.

Step 1

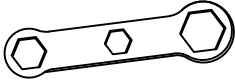

#C Closed-end Spanner X 1

Step 2



#14 Pan-head Hexagon Socket Set Screws
M6*45 X 4

#B Cross Hexagon Wrench X 1

Step 3

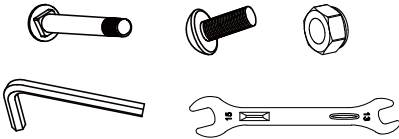

#11 Bolts M8*66 X 2

#12 Pan Head Hexagon Socket Full Tooth Screws
M6*13 X 5

#13 Nuts M8 X 2

#A Allen Key X 1

#D Open Spanner X 1

Step 4



#12 Pan Head Hexagon Socket Full Tooth Screws
M6*13 X 2

#B Cross Hexagon Wrench X 1

Step 5



#B Cross Hexagon Wrench X 1

Step 6

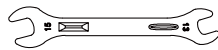

#D Open Spanner X 1

Step 7



#B Cross Hexagon Wrench X 1

Step 8



#28 Cross Recessed Pan Head Screws M5*13 X 2

#B Cross Hexagon Wrench X 1

Assembly Instructions



Tips

Scan QR code to watch installation video

Step 1: Install the Foot Tubes

A. Remove pre-assembled Cured Washer(#23) and Cap Nuts(#24) from the Front Foot Tube(#21) and Rear Foot Tube(#22).

B. Use 4 Cured Washer(#23) and 4 Cap Nuts(#24) to install Front Foot Tube(#21) and Rear Foot Tube(#22) onto Main Frame(#8) by the Closed-end Spanner#C).

Note: Please ensure the both tubes are installed on the correct position as shown below.

C. Tighten Cap Nuts(#24) at the both foot tubes.

Note: The Cured Washer(#23) and Cap Nuts(#24) is pre-assembled onto the foot tube.

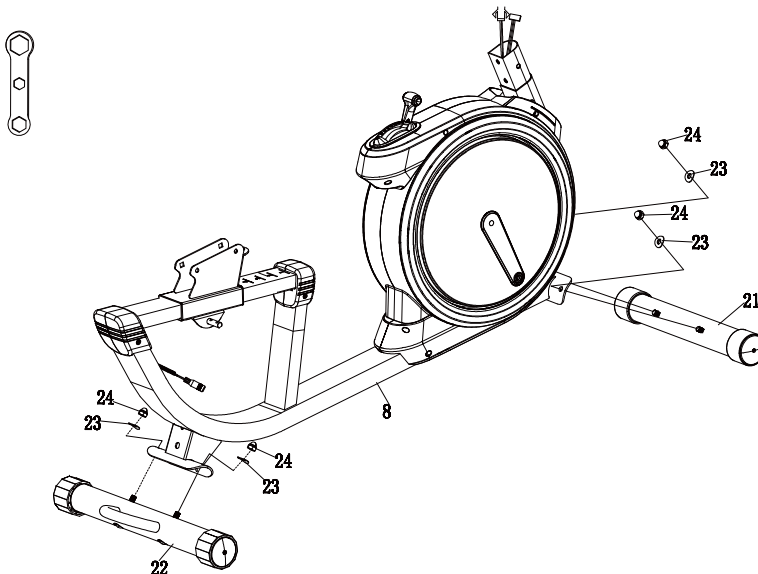

Assembly Instructions

Step 2: Lock the Back Cushion and Rear Handle

A. Attach the Seat Cushion(#10) to the Backrest Support(#18) with Pan Head Hexagon Socket Full Tooth Screws (#12) by the Allen Key(#A).

B. Attach the Backrest(#26) to the Backrest Support(#18) with Pan-head Hexagon Socket Set Screws(#14) by the Allen Key(#A).

C. Attach the Rear Handle(#15) to the Backrest Support(#18) with Seat Handle Hook(#16) and Pan Head Hexagon Socket Full Tooth Screws(#17) by the Cross Hexagon Wrench(#B).

Note: The 2 Pan Head Hexagon Socket Full Tooth Screws(#17) is pre-assembled onto the Seat Handle Hook(#16).

Note: The Rear Handle(#15) is rotatable (maximum 90 degrees) for the user to seat into cushion easily.

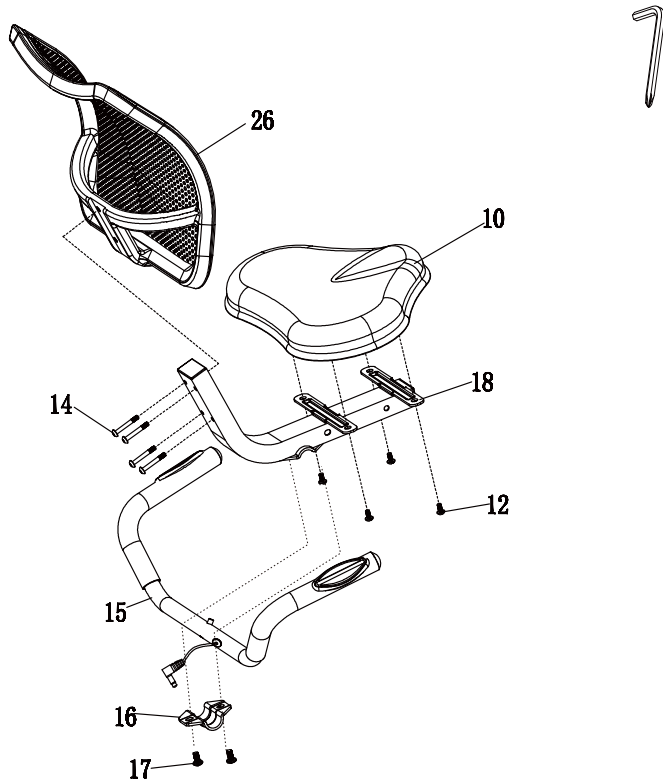

Assembly Instructions

Step 3: Install the Seat Set to the Main Frame

A. Attach the Backrest Support(#18) to the seat slider on the Main Frame(#8) with Pan Head Hexagon Socket Full Tooth Screws(#11), Nuts(#13) and Bolts(#12) from the bottom of the seat slider. And then tighten it with Open Spanner(#D).

Note: Please unscrew the pre-assembled 1 Pan Head Hexagon Socket Full Tooth Screws (#12) from the Backrest Support(#18) firstly.

B. Connect the Handle Wire(#27) to the Handle Chip Trunk(#28).

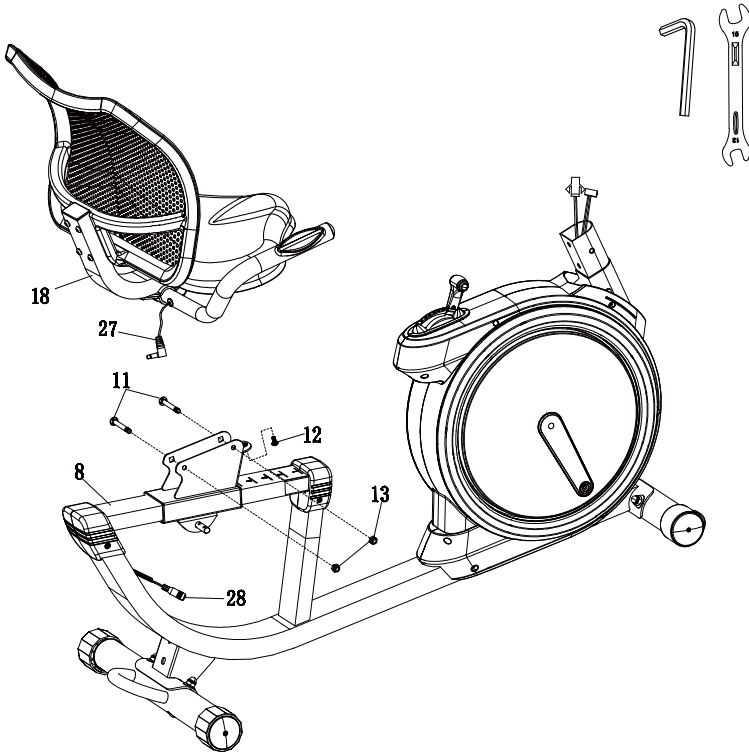

Assembly Instructions

Step 4: Install the Seat Cushion Adjustment Lever

A. Slider the Seat Cushion Adjustment Lever(#25) onto the Lever Connect Located under the Seat(#10) and secure with Bolts(#12) and Cross Hexagon Wrench(#B).

Note: The Bolts(#12) is pre-assembled on the Main Frame(#8).

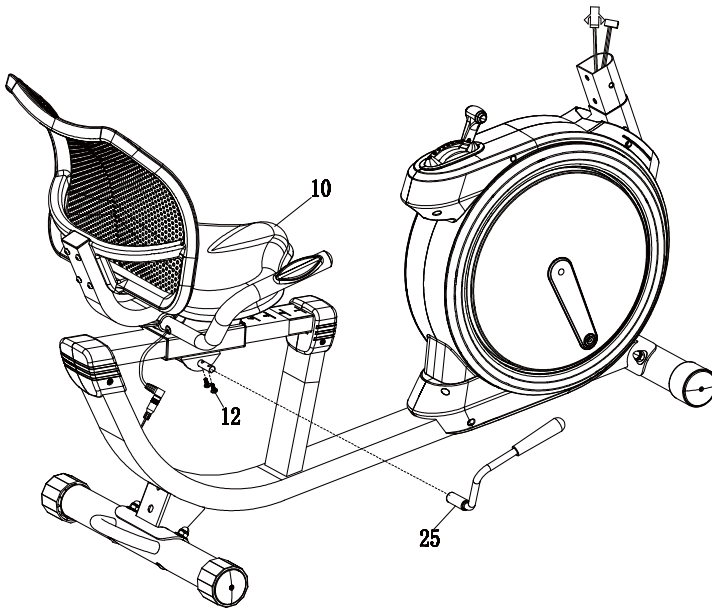

Assembly Instructions

Step 5: Install the Support Tube

A. Slide the Decorative Cover (#7) on the Support Tube (#5) as shown in the illustration below.

B. Connect the Middle Meter Wire on the Support Tube (#5) to the Lower Meter Wire on the Main Frame (#8).

C. Connect the Pulse Sensor Wire on the Support Tube (#5) to the Pulse Sensor Wire on the Main Frame (#8).

D. Insert the Support Tube(#5) onto the Main Frame(#8) and secure it with Bolts(#6) and Cross Hexagon Wrench(#B).

E. Slide the Decorative Cover (#7) down to cover the bolts.

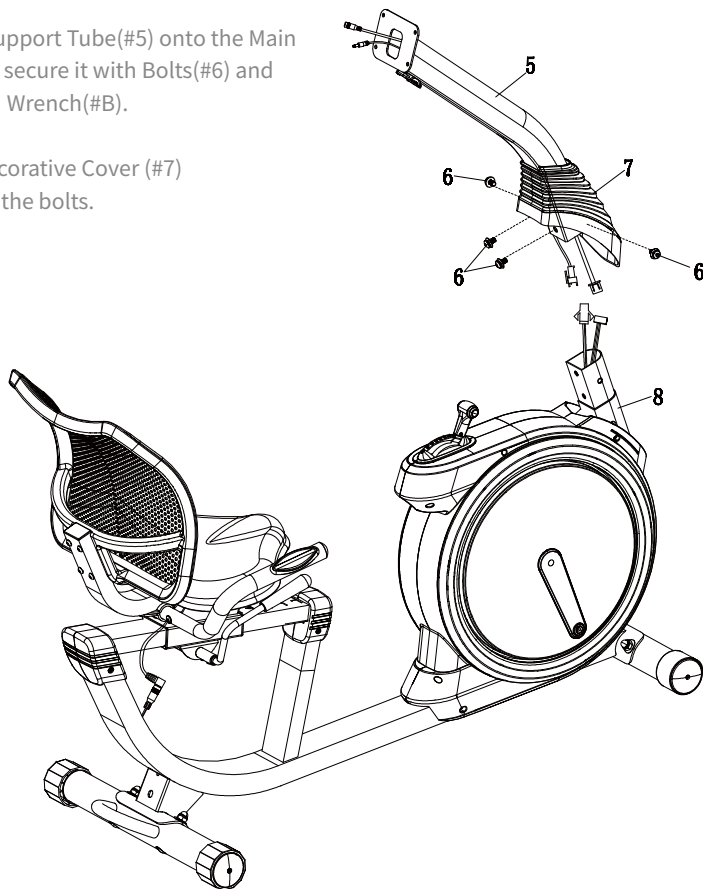

Assembly Instructions

Step 6: Install the Pedals

A. Assemble the left and right pedals (#20L) and (#20R) with the straps as shown in Figure.

B. Lock the left and right pedals (#20L) and (#20R) on the crank (#29) respectively.

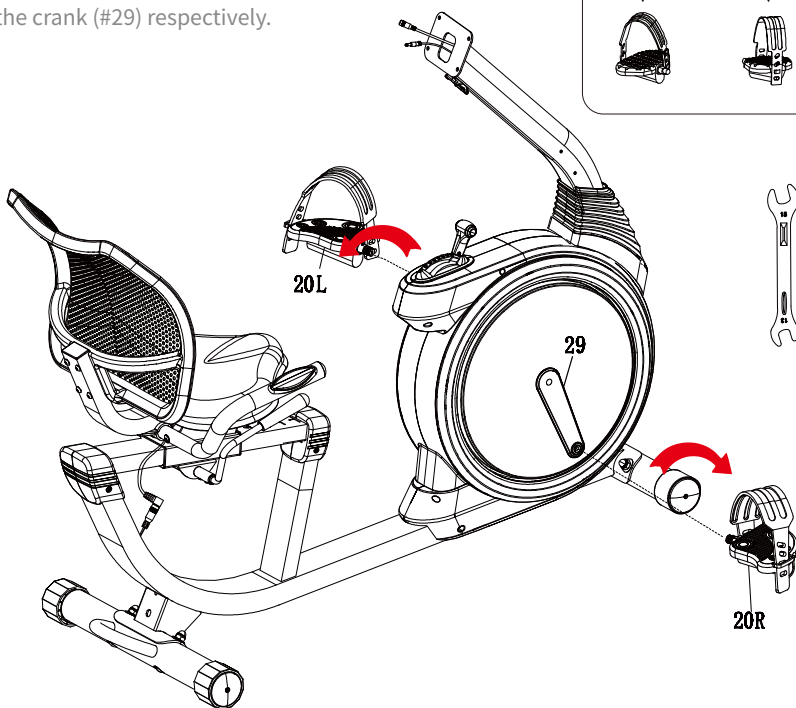
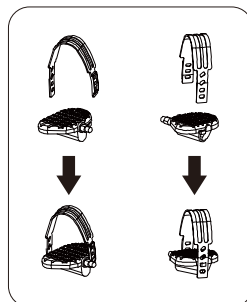

Left Pedal: Align the Left Pedal(#20L) with the Left Crank Arm at 90 degrees. Insert pedal into crank arm, then turn pedal counter-clockwise as tightly as you can by hand. Tighten and secure with Open Spanner(#D).

Right Pedal: Align the Right Pedal(#20R) with the Right Crank Arm at 90 degrees. Insert pedal into crank arm, then turn pedal clockwise as tightly as you can by hand. Tighten and secure with Open Spanner(#D).

Assembly Instructions

Step 7: Install the Handlebar and the Monitor

A. Attach the Handlebar (#9) to the Support Tube (#5) with Bolts (#3). Clip the Handlebar Cap (#4) onto the Handlebar (#9) to cover the Bolts (#3).

B. Plug the Middle Meter Wire on the Support Tube (#5) and the Pulse Sensor Wire into the connecting wires of the Monitor(#1), and push the excess wires back into the Support Tube (#5).

C. Attach the Monitor(#1) to the plate on the Support Tube(#5) with Bolts(#2) and Cross Hexagon Wrench (#8)

NOTE: Please be careful not to damage the wires when attaching the Monitor(#1), and 4 Bolts(#2) are pre-assembled onto the back of Monitor(#1).

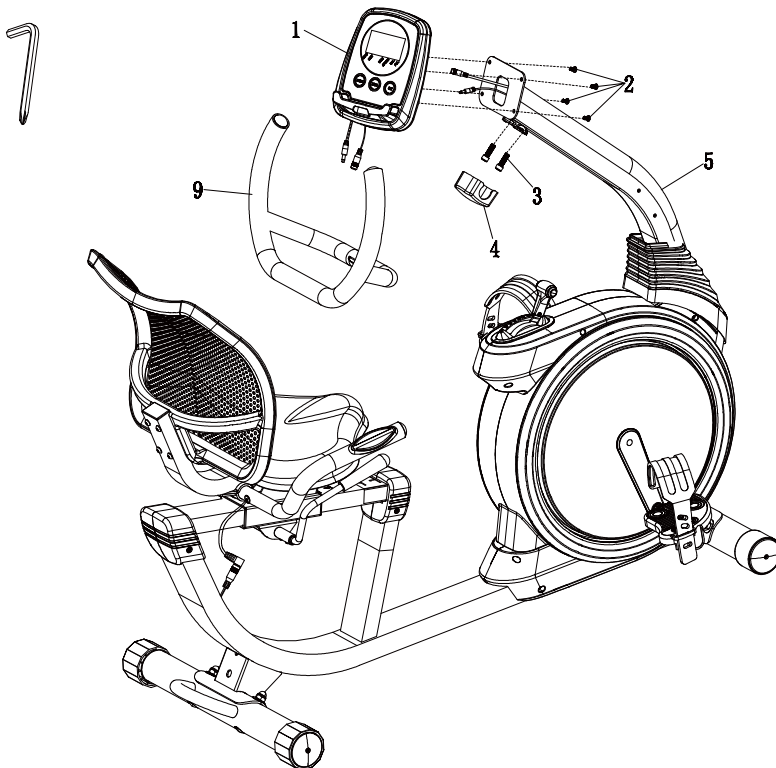

Assembly Instructions

Step 8: Fix the bottle cage

A. Use the Cross Hexagon Wrench(#B) to tighten the Bottle Cage(#27) with Cross Recessed Pan Head Screws(#28) to lock on the Handlebar Post(#5).

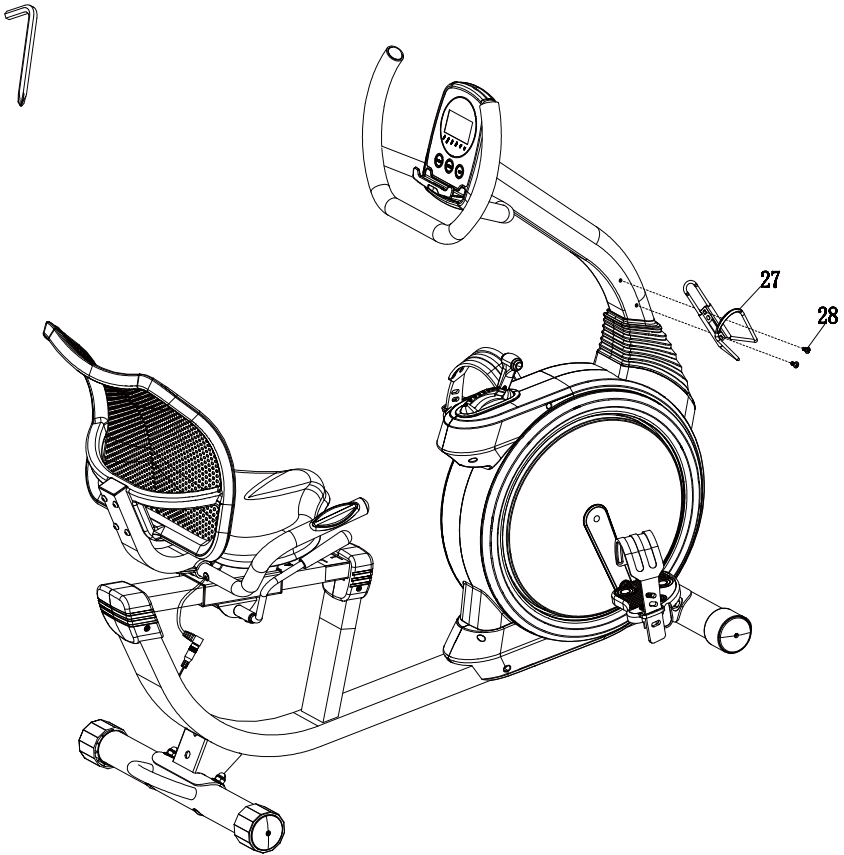

Product Usage Instructions

Seat Cushion Adjustment Instructions

A. Carry the Seat Cushion Adjustment Lever(#25) up, and then move the Seat Cushion(#10) back or forth to choose a suitable position for users.

B. Press the Seat Cushion Adjustment Lever(#25) down completely.

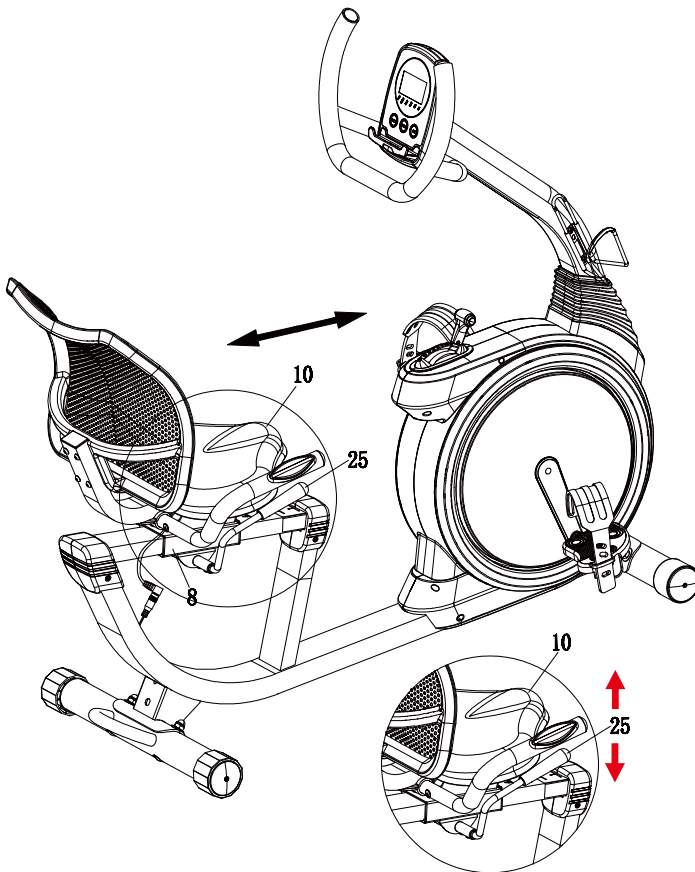

Product Usage Instructions

Resistance Adjustment Instructions

Adjust the Resistance Gear Handle to change the gear of bike as shown.

Pull the gear handle back to increase resistance
(The number 8 represents the maximum resistance);

Push the gear handle forward to decrease resistance
(The number 1 represents the minimum resistance).

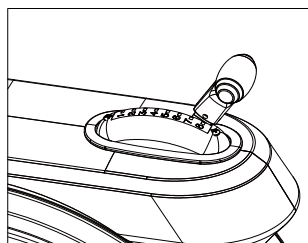
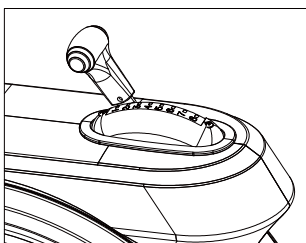
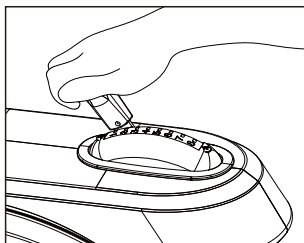

Machine Movement Instructions

Drag back and forth by grasping the curved handle of Rear Foot Tube(#22)with your hand and the front foot tube(#21)touching the ground.

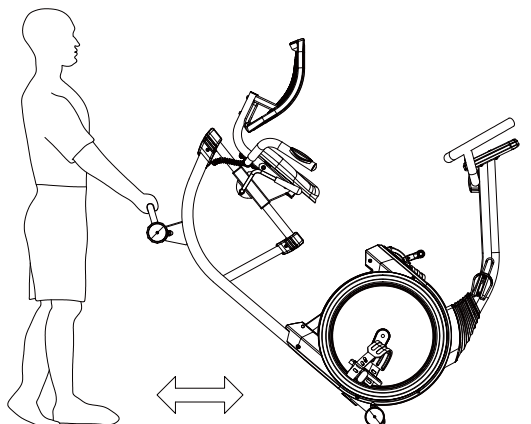

Product Usage Instructions

Rear Foot Tube Adjustment Instructions

Please adjust the twelve eccentric foot sleeve (#30) on the rear foot tube (#22) as needed to make the exercise bike stable without shaking.

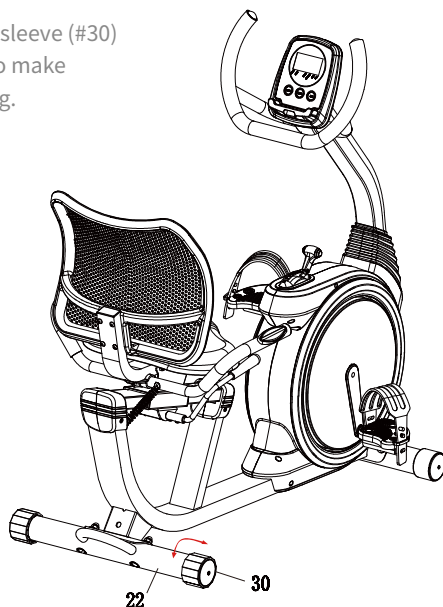

Batteries Installation Instructions

Remove the back cover by hand (Figure A), then prepare the batteries (Figure B), then install two batteries, cover the back cover (Figure C), and the battery assembly is completed (Figure D).

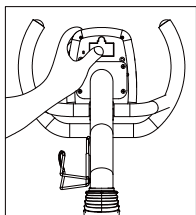

A

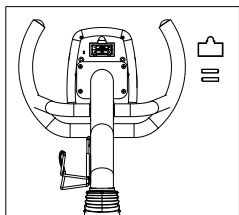

B

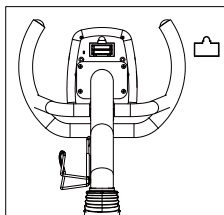

C

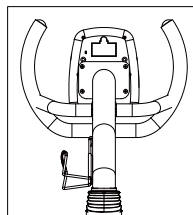

D

Instruction of Monitor

Functional Buttons:



MODE: Push down for selecting functions.

(If the long time holds down MODE button will turn completely 0.)

SET: To set the values of time, distance, pulse and calories when not in scan mode.

RESET: Push down for resetting time, distance and calories.

The current data change is 0. If the long time holds down RESET, besides the ODO position, the material will turn completely 0.

Instruction of Monitor

Function and Operations :

1. SCAN:

Press "MODE" button until "SCAN" appears, monitor will rotate through all the 5~6 functions. Time, speed, distance, calorie, ODO and pulse. Each display will be hold 6 seconds.

2. TIME:

(1) Count the total time from exercise start to end.

(2) Press "MODE" button until "TIME" appears, press "SET" button to set exercise time.

When the "SET" is zero, the monitor will alarm 10 seconds.

3. SPEED:

Display current speed.

4. DIST:

(1) Count the distance from exercise start to end.

(2) Press "MODE" button until "DIST" appears, press "SET" button to set exercise distance.

When the "SET" is zero.

5. CALORIES:

(1) Count the total calories from exercise start to end.

(2) Press "MODE" button until "CAL" appears, press "SET" button to set exercise calories.

When the "SET" is zero, the monitor will alarm 10 seconds.

6. ODO:

The total distance that this function refers to from battery capacity period runs.

7. PULSE RATE:

Press MODE button until "PULSE" appears. Before measuring your pulse rate, please place the palms of your hands on both of your contact pads and the monitor will show your current heart beat rate in beats per minute(BPM) on the LCD after 6~7 seconds.

Remark: During the process of pulse measurement, because of the contact jamming, the measurement value may be higher than the virtual pulse rate during the first 2~3 seconds, then will return to normal level. The measurement value cannot be regarded as the basis of medical treatment.

8. ALARM:

The computer will "Beep" when press "MODE","SET" and "RESET" buttons.

9. AUTO ON/OFF & AUTO START/STOP:

Without any signal for 4 minutes, the power will turn off automatically. As long as the wheel is in motion or press any button, the monitor is in action.

Instruction of Monitor

FUNCTION	Auto Scan	Every 6 seconds
	Time	0:00-99:59
	Current Speed	Maximum speed 999.9 km/h
	Trip Distance	0.00~9999 (ML) KM
	Total Distance (ODO)	0.0~9999 (ML) KM
	Calories	0.0~9999 Kcal
	Pulse Rate	40~240 BPM
Battery Type		2 pcs of size - AA or UM - 3
Operating Temperature		0°C~+40°C
Storage Temperature		-10°C~+60°C

NOTE:

1. If the display is faint or shows no figures ,please replace the batteries.
2. The monitor will automatically shut off if there is no signal received after 4 minutes .
3. The monitor will turn on automatically after restarting the exercise or pressing the button.
4. The monitor will automatically start calculating when you start to exercise and will stop calculating when you stop exercising for 4 seconds .

Technical Details

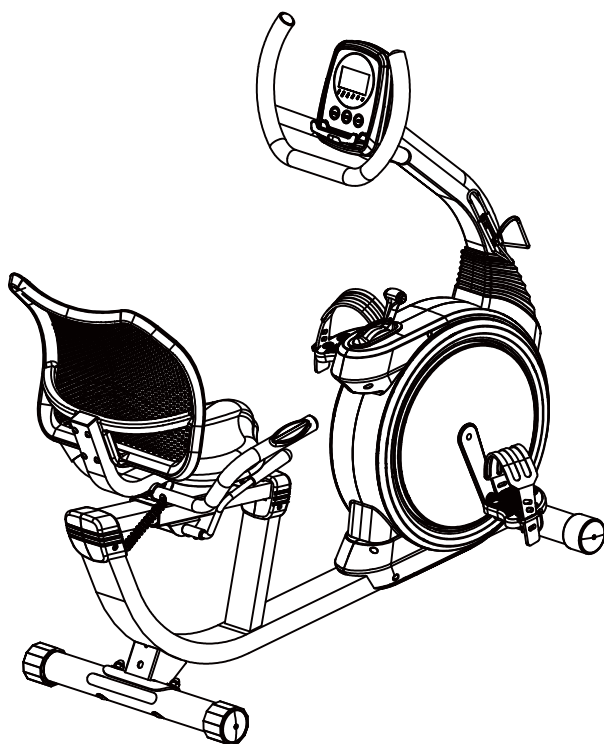

Resistance Mechanism :	Magnetic
Model Name :	MR-S19
Maximum User Weight :	330lbs
Item Weight :	85.32lbs/38.7kg
Item Dimensions :	48.03*23.62*46.46inch/1220*600*1180mm
Item Package Dimensions :	50.2*11.1*24.6inch/1275*282*625mm

MERACH APP SETUP

Download and use of MERACH

- * **Our customer can get a 180-day MERACH membership. Please contact us through support@merach.com after receiving the product to get an exclusive redemption code. Please include your order ID and MERACH app Username.**

1. To download the MERACH app, scan the QR code or search "MERACH" in the Apple App Store® or Google Play Store.



MERACH APP Download



APP Connection Guide



2. Open the MERACH app. Log In or Sign Up.
3. Follow the in-app instructions to set up your device.

KINOMAP APP SETUP

Download and use of KINOMAP



1. To download the Kinomap app, scan the QR code or search "Kinomap" in the Apple App Store® or Google Play Store.
2. Open the Kinomap app. Log In or Sign Up.
3. Select the corresponding fitness equipment
4. Turn on Bluetooth, and choose Merach.
5. Select "Recumbent Bike", and find your "MR-S19-XXXX".
6. Start training and explore different workout methods.

Warm-up

Do stretches before exercising. Warm muscles are easier to stretch, so start with a 5-10 minute warm-up, then do some stretches shown below - 5 times, 10 seconds or more per leg. Do it again after the workout.

1. Stretch down

Bend your knees slightly, slowly bend your body forward, relax your back and shoulders, and try to touch your toes with your hands. Hold for 10-15 seconds, then relax.

Repeat 3 times (see Figure 1).



2. Seated hamstring stretch

Sit with one leg straight. Bring the other leg in so that it is snug on the inside of the straightened leg. Try to touch your feet with your hand's toe. Hold for 10-15 seconds, then relax.

Repeat 3 times for each leg (see Figure 2).

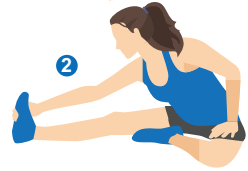

3. Calf and Achilles tendon stretch

Stand with both hands against the wall or a tree, put one foot behind another. Keep the back leg straight and your heel on the ground, lean toward a wall or a tree. Hold for 10-15 seconds, then relax. Repeat 3 times for each leg (see Figure 3).

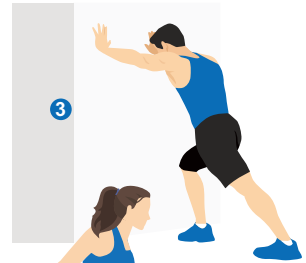

4. Quadriceps stretch

Reach back with your right hand, grab your right foot and slowly pull it toward your hips until you feel the muscles in the front of your thigh tense. Hold for 10-15 seconds, then relax.

Repeat 3 times for each leg (see Figure 4).



5. Sartorius (inner thigh muscle) stretch

Sit with your feet facing each other and your knees facing out. Grab your feet with both hands and pull toward your groin. Hold for 10-15 seconds, then relax.

Repeat 3 times (see Figure 5).



Troubleshooting

Problem	Possible Soutlion
Monitor no data display	Check whether the batteries are installed correctly.
	Replace the batteries.
	If the recumbent bike is still malfunctioning, please contact Customer Support (see page 24)
How to adjust gear?	Pull the gear handle back to increase resistance and push the gear handle forward to decrease resistance. The resistance of items is available with 8 gears.
	If the recumbent bike is still malfunctioning, please contact Customer Support (see page 24)
What to do when the handle shakes slightly?	Check whether the connecting screws of the handle and the front column tube are firmly fixed.
	If the recumbent bike is still malfunctioning, please contact Customer Support (see page 24)
Loose pedals while riding	Check whether the front and rear foot tubes are fastened enough.
	If the recumbent bike is still malfunctioning, please contact Customer Support (see page 24)

Warranty Information

Product Name	MERACH RECUMBENT BIKE
Model	MR-S19
Default Warranty Period	12 Months
For your own reference, we strongly recommend that you record your order number and date of purchase.	
Date of Purchase	
Serial Number	

Terms & Policy

The MERACH products are premium in material, craftsmanship, and service.

MERACH 1-year limited warranty is effective from the date of purchase.

MERACH will replace defective products based on eligibility. Refunds are available to the original purchasers of our products within the first 30 days of purchase.

This warranty extends only to personal use and doesn't apply to commercial, rental, or any other uses for which the product is not intended for.

There are no warranties other than the warranties expressly set forth with each product.

This warranty is non-transferable. MERACH is not responsible for any damages, losses, or inconveniences caused by equipment failure, user negligence, user abuse, or improper operation that does not follow the included user manual.

This warranty does not apply to the following situations:

- Damage due to abuse, accident, alteration or vandalism.
- Improper or inadequate maintenance.
- Damage in return transit.
- Unsupervised use by children under 18 years old.

MERACH and its subsidiaries are only responsible for damages caused by the intended use or as instructed in the user manual. Some states do not allow this exclusion or limitation of incidental or consequential losses, so the above disclaimer may not apply to you. This warranty gives you specific legal rights and you may also have other rights, which may vary from state to state.

All expressed and implied warranties, including the warranty of merchantability, are limited to the period of the limited warranty.

MERACH

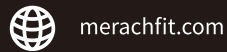

Customer Service: support@merach.com

Official Website: merachfit.com