

Bread Maker

User's manual

EN



SENCOR®

SBR 1031WH
SBR 1032SS

Before first use, please read all instructions contained in this user's manual carefully, even if you are already familiar with using similar products. Only use this product in accordance with the instructions described in the user's manual. Keep this manual for future use.

Save the original packaging, including the internal packing material, warranty card and proof of purchase receipt at least for the duration of the warranty. If you need to ship this product, pack it in the original cardboard box to ensure maximum protection during shipping or transport (e.g. when moving or when you need to send this product for repair).

EN-1

CONTENTS

IMPORTANT SAFETY NOTICE	3
DESCRIPTION OF THE BREAD MAKER	5
DESCRIPTION OF THE CONTROL PANEL	6
BEFORE FIRST USE	7
DESCRIPTION OF THE PROGRAMS	7
USING THE BREAD MAKER	8
OVERVIEW OF SOUND SIGNALS	9
USING THE TIMER	9
INTERRUPTION OF THE POWER SUPPLY	10
SLICING AND STORING THE BREAD	10
CLEANING AND MAINTENANCE	11
OVERVIEW OF INDIVIDUAL PROGRAM STAGES	12
BAKING BREAD	15
RECIPES	17
BAKING TROUBLESHOOTING GUIDE	26
TECHNICAL INFORMATION	28
INSTRUCTIONS AND INFORMATION REGARDING THE DISPOSAL OF USED PACKAGING MATERIALS	28
DISPOSAL OF USED ELECTRICAL AND ELECTRONIC EQUIPMENT	28

IMPORTANT SAFETY NOTICE

This appliance may be used by children 8 years of age and older and by persons with physical or mental impairments or by inexperienced persons if they are properly supervised or have been informed about how to use of the appliance in a safe manner and understand the potential dangers. Cleaning and maintenance must not be performed by children unless they are older than 8 years of age and under supervision. Do not allow children to play with the appliance.

Keep this appliance and the power cord out of reach of children younger than 8 years of age.

IMPORTANT SAFETY NOTICE

- 1) Before putting the product into operation, carefully read the entire user's manual.
- 2) Check that the voltage in your electricity grid corresponds to the voltage specified on the rating label of the appliance.
- 3) Never use the appliance if it has a damaged power cord or plug (e.g. by sharp or hot objects, an open flame, etc.), if it has broken down, if it has fallen on the floor and been damaged, or if it is damaged in any other way. In such cases, never attempt to repair the appliance yourself, but take it to an authorised service centre.
- 4) Please be aware that during baking, hot steam is emitted from the appliance and the surface of the appliance is hot.
- 5) Never submerge the appliance in water.
- 6) If you are not using the appliance, disconnect the power cord from the electrical mains socket. Likewise, when cleaning the appliance disconnect the power cord.
- 7) Do not leave the power cord hanging over the edge of a table or laying on a hot surface (e.g. hotplate). Likewise, do not leave the appliance standing on a hot surface.

**Note:**

This appliance is not designed to be controlled using a programmed device, external timer switch or remote control.

- 8) While in operation, do not touch any moving or rotating parts of the appliance.
- 9) Never attempt to switch on the appliance if the baking container is not correctly inserted together with the desired ingredients.
- 10) Never attempt to remove the baking container by banging on its top part or sides - this could damage it.
- 11) It is forbidden to place metal foils or other materials into the appliance. If this warning is not heeded there exists a danger of a fire or short circuit.
- 12) In the direction of the main heat emissions, a safety distance must be kept from the surface of flammable materials of at least 50 cm and in other directions of at least 10 cm.
- 13) Never cover the bread maker with a wiping cloth, towel or other materials - unhindered heat and steam removal must be made possible. If covered or other contact with flammable material exists this could lead to a fire.
- 14) Do not use the appliance for purposes other than those for which it is designed.
- 15) This appliance is designed for household use only.
- 16) Do not use the appliance for indoor heating purposes.
- 17) Do not use the appliance outdoors.
- 18) The manufacturer is not responsible for damages caused by the incorrect use of this appliance or its accessories. Such damages include food spoilage, injuries, burns, scalding, fire, etc.

Bread Maker

SBR 1031WH / SBR 1032SS

EN

DESCRIPTION OF THE BREAD MAKER

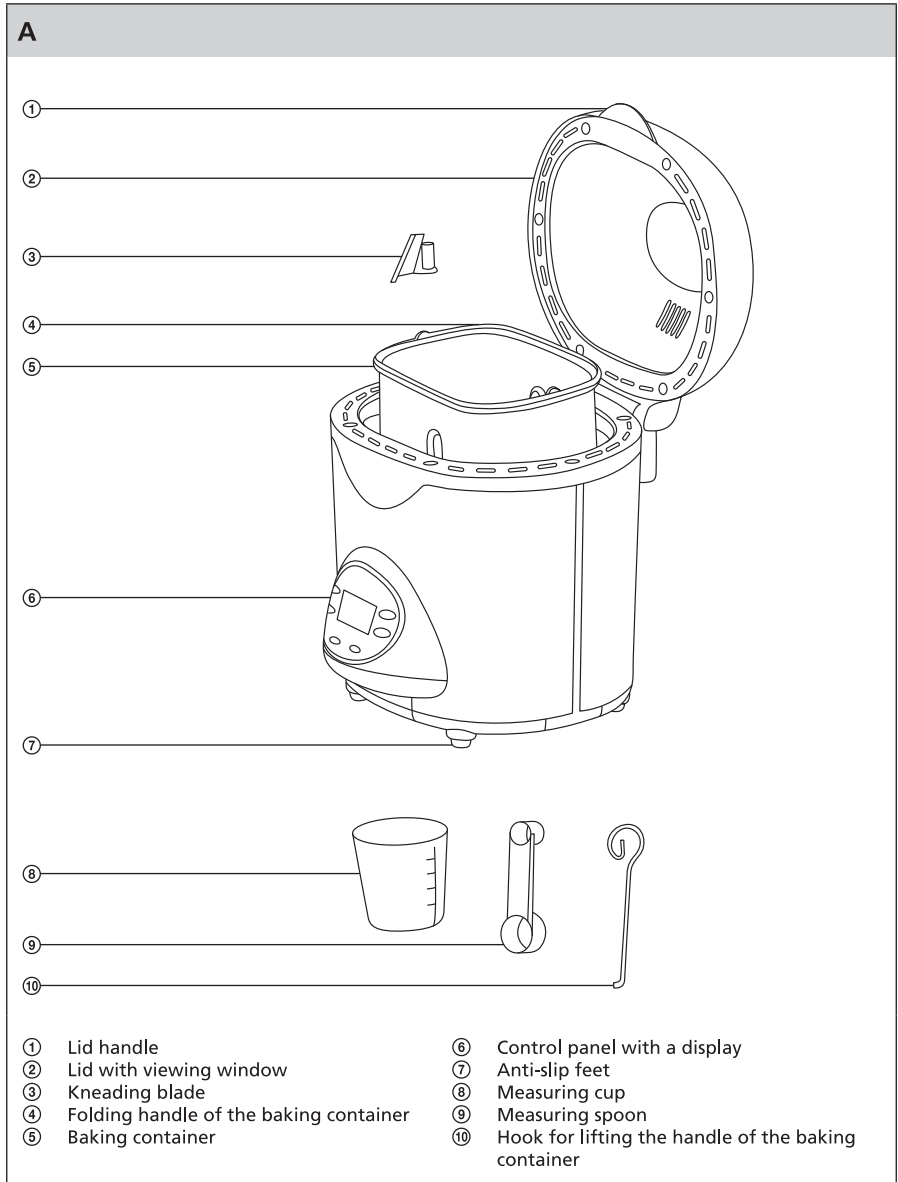

EN-5

DESCRIPTION OF THE CONTROL PANEL

B

- | | |
|----------------------------------|-------------------------------|
| 1. BASIC / Základní pečení | 7. KNEADING / Hnětění |
| 2. FRENCH / Francouzský chléb | 8. JAM / Džem |
| 3. SWEET / Sladký chléb | 9. YOGURT / Jogurtový chléb |
| 4. CAKE / Koláč | 10. DOUGH / Těsto |
| 5. WHOLE WHEAT / Celozrnný chléb | 11. FAST BAKE / Rychlé pečení |
| 6. SANDWICH / Toastový chléb | 12. BAKE / Pečení |

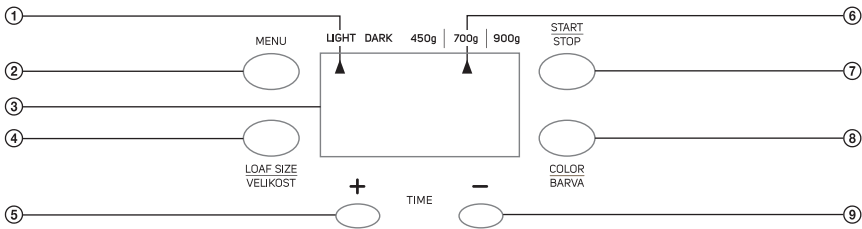

- ① Crust colour setting indicator
- ② Program selection button
- ③ Display
- ④ Loaf size setting button
- ⑤ Delayed start setting button

- ⑥ Loaf size setting indicator
- ⑦ START/STOP button
- ⑧ Crust colour selection button
- ⑨ Delayed start setting button

BEFORE FIRST USE

Before first use, please find a few minutes to read the user's manual and then store it in an appropriate location, so that it is on hand if needed. Pay attention namely to the safety instructions.

- 1) Carefully unpack the bread maker and remove all packaging materials.
- 2) Remove dust which may have accumulated during packaging.
- 3) Clean the baking container, kneading blade and the outside surface of the bread maker with a damp clean cloth.

The bread baking container has a non-stick layer. Do not use steel wool or any other objects with an abrasive effect to clean any part of the bread maker.

- 4) On first use, smear the bread pan with oil, butter or margarine and bake without any ingredients for a period of no longer than 3–5 minutes (select the Bake program).
- 5) Allow the bread maker to cool and clean it again.
- 6) Place the kneading blade on to the shaft in the baking container.

PROGRAM DESCRIPTION

1) BASIC (Standard baking)

This program is used for baking standard types of bread from white wheat flour.

2) FRENCH (French bread)

This program is used for baking traditional French white bread with a fluffy inside and crunchy crust.



Recommendation:

French style bread will not last long, consume it the same day that it was baked.

3) SWEET (Sweet bread)

This program is used for baking sweet bread with a higher content of fat and sugar and with additions like dried fruit, nuts, chocolate chips, sweetened orange peels, etc.

4) CAKE

This program is used for baking cakes and sweet baked goods made from dough containing baking powder.

5) WHOLE WHEAT (Whole wheat bread)

This program is used for baking bread containing whole grain flour.



Recommendation:

We do not recommend the delayed start function with this program. Otherwise the quality of the bread could be negatively affected.

6) SANDWICH (Sandwich bread)

This program is used for baking fluffy sandwich bread which is suitable for making sandwiches.

7) KNEADING

This program is used for mixing / kneading ingredients. In this program it is not possible to select the crust colour or loaf weight because it does not have a baking stage. When the program is finished, tip the dough out of the baking container and allow it to rest for approximately 10 minutes before working with it.

8) JAM

This program is used for making jams from various types of fruits. Cook the jam in smaller batches because its volume increases during the cooking process. Jam is sticky and if it flows out of the baking container, it is very hard to remove.

- 9) **YOGURT (Yogurt bread)**
This program is used for baking bread containing a yogurt component.
- 10) **DOUGH**
This program is used for mixing/kneading ingredients and then subsequently rising the dough, for example for pizza, bread rolls, etc. It does not, however, include the baking stage.
- 11) **FAST BAKE**
This program is a faster alternative of the Basic / Standard baking program.
- 12) **BAKE**
The Bake program makes your bread maker into a small oven. In this program, the baking time is preset to 1 hour. The preset baking time can be shortened by pressing the TIME- button. Confirm the setting using the START/STOP button. This program is usually used for baking store-bought ready-made dough or for additional baking of a just finished bread loaf when you feel the crust is too light.

USING THE BREAD MAKER

- 1) **Take out the container**
Open the lid and take out the baking container by lifting the handle - pull it out with a firm pull upwards. Place it on a work surface. It is important that the baking container is filled with ingredients outside the bread maker, so that if the ingredients are accidentally spilt they do not get into the bread maker.
- 2) **Attach the kneading blade**
Push the kneading blade down to attach it to the shaft, which is located on the bottom of the baking container.
- 3) **Measure out the ingredients**
Measure out the required ingredients and in the described sequence add them all into the baking container (see part "BAKING BREAD" in the next part of the user's manual).
- 4) **Insert the baking container back into the bread maker**
Insert the baking container back into the bread maker and press it down firmly so that it clicks into the correct position. Close the lid.
- 5) **Connect the bread maker to a power socket**
Connect the bread maker by inserting the power cord into a power socket. The connection to the power socket is indicated by a sound. The display will show "1" and "2:50", which means that the bread maker is preset to the default program 1 (Basic / Standard baking), which takes 2 h 50 mins to bake a 450g loaf.
- 6) **Select a program**
Press the "MENU" button to select the desired program number from the list.
- 7) **Set the weight**
Press the "LOAF SIZE" button to select the loaf size (450 g / 700 g / 900 g).



Attention:

Keep in mind that you are always selecting the total weight of the loaf and not just of the baking mix!

- 8) **Select the crust colour**
Press the "COLOUR" button to select the desired crust colour (**LIGHT** or **DARK**).
- 9) **Select the delay time**
If you wish to have the bread baked later, set a delay time – see description in another part.

- 10) **Start the bread maker**
Press the "START/STOP" button to start the bread maker. The display's backlight will start flashing in 5 second intervals. The remaining time will be counted down in minutes.
- 11) **Baking stages**
The bread maker will automatically proceed through the individual program phases. During the kneading stage (only in some programs) a sound is made (10 beeps), which indicates the option of adding dried fruit, nuts, etc.
- 12) **End of baking**
When the program finishes, "0:00" will appear on the display and a sound will be made (12 beeps).
- 13) **Keep warm**
The keep warm function will with most programs ensure the circulation of hot air for another 60 minutes (see part "OVERVIEW OF INDIVIDUAL PROGRAM STAGES"). A sound will be made when the keep warm time is finished. To end the keep warm function prematurely, press the "START/STOP" button and hold it pressed down until you hear a beep.
- 14) **Take out the baking container**
Press the "START/STOP" button and hold it pressed down until you hear a beep, then open the lid and use a hook to lift the handle of the baking container. Use a kitchen glove to take the baking container out of the bread maker.
- 15) **Take out the bread**
Allow the bread to cool in the baking container for 10–15 minutes, then turn the baking container over and pull the bread out of the pan to let it cool.
- 16) After you finish using the bread maker, always disconnect the power cord from the el. power supply.

OVERVIEW OF SOUND SIGNALS

1 long beep

– connection to the bread maker to the el. power socket.

1 short beep

– a button is pressed on the control panel;
– indication that a program is started in the delayed start mode.

5 beeps

The temperature inside the bread maker is too high. Before starting it again, it is necessary to wait until the bread maker cools down.

10 beeps

You can add ingredients such as dried fruit, nuts, in the Kneading 2 stage in the BASIC, FRENCH, SWEET, WHOLE WHEAT or SANDWICH programs.

12 beeps

End of program announcement. The Keep warm stage will follow in all programs that include the baking stage.

USING THE TIMER

Use the timer if you want to have your bread finished later. Do not use this function for recipes containing ingredients that spoil quickly, for example fresh eggs, milk, sour cream, cheese, etc.

Example:

It is 9:00 p.m. and you want a 700 g white bread from white wheat flour finished in the morning at 8:00 a.m. (i.e. a 11-hour time difference).

Bread Maker

SBR 1031WH / SBR 1032SS

- 1) Place the ingredients into the baking container and place the container into the bread maker.
- 2) Use the "**MENU**" button to set program 1 (Basic / Standard baking).
- 3) Use the "**LOAF SIZE**" button to select the loaf size 700 g.
- 4) Use the "**COLOUR**" button to select the crust colour.
- 5) The display will show the total program time of 2:55 (2 h 55 mins). Use the **TIME+** and **TIME-** button to adjust the time so that 11:00 is shown on the display. This is the time after which the bread will be ready to be taken out of the bread maker. Each time that the **TIME+** or **TIME-** button is pressed, the set time will be reduced or increased by 10 minutes.
- 6) To start the program in the delayed start mode, press the "**START/STOP**" button. The time will start to countdown on the display.

**Note:**

The start of the program can be delayed by a maximum of 10 hours.

As soon as the set program is started, regularly check the bread maker. During the Kneading 2 stage (time of 2:15 on the display), a sound will be made (10 beeps) indicating the option of adding dried fruit, nuts, etc. If you wish to add these ingredients, open the lid and add dried fruit, nuts, etc. The bread maker will continue with the set program. When the program ends, a sound is made (12 beeps) and the bread maker automatically switches to the keep warm mode.

**Attention:**

Do not press the **START/STOP** button before opening the lid otherwise the program will be cancelled.

INTERRUPTION OF ELECTRICAL POWER

After a short interruption to the power supply (max. 20 minutes) the bread maker will automatically continue on with the set program once electrical power is restored.

After a longer power supply interruption, the bread maker will return back to the start time:

- If the "rising 1" stage has not yet started, select the required program again and press the "**START/STOP**" button.
- If the program completed the "rising 1" stage, then you will need to start again with fresh ingredients.

SLICING AND STORING THE BREAD

- To achieve the best possible results, allow the bread to cool for a period of 30–40 minutes before slicing it.
- To achieve even slices use an electrical knife or a knife with a serrated edge.
- Bread that has not been consumed can be tightly packed into a plastic bag and stored at room temperature for a period of up to 3 days. If it is hot and humid then place the bread into the refrigerator overnight.
- If you wish to store the bread for a longer period of time (up to 1 month), place it into a sealed container and place this container into the freezer.
- If you put the bread into a refrigerator, wait until it has reached room temperature before serving.
- Because homemade bread does not contain any preservatives, it has a tendency to go dry and hard earlier than bread from the supermarket.

CLEANING AND MAINTENANCE

Before cleaning disconnect the appliance from the power source and allow it to cool down.

- 1) Baking container: Clean from inside and outside using a damp cloth. To prevent damaging the non-stick layer, do not use any sharp or abrasive cleaning products. The baking container must be completely dry before installation.
- 2) Kneading blade: If it is difficult to release the kneading blade from the shaft fill the pan with warm water and allow it to take effect for about 30 minutes. After 30 minutes, you should be able to easily remove the kneading blade. Carefully clean the kneading blade with a cotton cloth.
- 3) Lid and viewer window: Clean the lid from inside and outside using a slightly damp cloth.
- 4) Cover: Carefully clean the outside surface of the cover with a damp cloth. Do not use cleaning abrasive cleaning products because the high shine of the surface could be damaged. Never submerge the lid in water during cleaning.
- 5) Before packing up the bread maker for storage, ensure that it has cooled down completely, that it is clean and dry, and that the lid is closed.



Attention:

- Brown stains may appear on the inside surface of the lid and ventilation openings. These are the remains of vapours from ingredients which got into the escaping steam during baking. They do not have any harmful effect on the bread maker or on the quality of the baked bread. Simply, after each use (or when they appear) remove them using a cloth or sponge dipped into warm water.
- After a long period of use, the surface layer of the baking container may change colour – this is caused by heat and humidity. The change in colour does not have a negative effect on the function of the bread maker or the quality of the bread.



Tip:

After cleaning place a drop of cooking oil into the opening in the middle of the kneading blade and put it back on to the shaft in the baking container.

Bread Maker

SBR 1031WH / SBR 1032SS

OVERVIEW OF INDIVIDUAL PROGRAM STAGES

Program	1 – Basic					
	Light			Dark		
Crust colour						
Weight	450 g	700 g	900 g	450 g	700 g	900 g
Delayed start	0–10 h	0–10 h	0–10 h	0–10 h	0–10 h	0–10 h
Preheating	-	-	-	-	-	-
Kneading 1	15 min	15 min	15 min	15 min	15 min	15 min
Resting	10 min	10 min	10 min	10 min	10 min	10 min
Kneading 2	15 min	15 min	15 min	15 min	15 min	15 min
Rising 1	38 min	38 min	38 min	38 min	38 min	38 min
Creation of an opening	1 min	1 min	1 min	1 min	1 min	1 min
Rising 2	39 min	40 min	41 min	39 min	40 min	41 min
Baking	52 min	56 min	60 min	52 min	56 min	60 min
Reheating	60 min	60 min	60 min	60 min	60 min	60 min
Total time	02:50	02:55	03:00	02:50	02:55	03:00
Time for addition of dried fruit, nuts, etc.	02:15	02:20	02:25	02:15	02:20	02:25

Program	2 – French					
	Light			Dark		
Crust colour						
Weight	450 g	700 g	900 g	450 g	700 g	900 g
Delayed start	0–10 h	0–10 h	0–10 h	0–10 h	0–10 h	0–10 h
Preheating	-	-	-	-	-	-
Kneading 1	15 min	15 min	15 min	15 min	15 min	15 min
Resting	33 min	35 min	39 min	33 min	35 min	39 min
Kneading 2	15 min	15 min	15 min	15 min	15 min	15 min
Rising 1	42 min	45 min	45 min	42 min	45 min	45 min
Creation of an opening	1 min	1 min	1 min	1 min	1 min	1 min
Rising 2	49 min	49 min	50 min	49 min	49 min	50 min
Baking	55 min	60 min	65 min	55 min	60 min	65 min
Reheating	60 min	60 min	60 min	60 min	60 min	60 min
Total time	03:30	03:40	03:50	03:30	03:40	03:50
Time for addition of dried fruit, nuts, etc.	02:32	02:40	02:46	02:32	02:40	02:46

Program	3 – Sweet					
	Light			Dark		
Crust colour						
Weight	450 g	700 g	900 g	450 g	700 g	900 g
Delayed start	0–10 h	0–10 h	0–10 h	0–10 h	0–10 h	0–10 h
Preheating	-	-	-	-	-	-
Kneading 1	15 min	15 min	15 min	15 min	15 min	15 min
Resting	10 min	11 min	12 min	10 min	11 min	12 min
Kneading 2	15 min	15 min	15 min	15 min	15 min	15 min
Rising 1	34 min	34 min	34 min	34 min	34 min	34 min
Creation of an opening	1 min	1 min	1 min	1 min	1 min	1 min
Rising 2	43 min	43 min	43 min	43 min	43 min	43 min
Baking	52 min	56 min	60 min	52 min	56 min	60 min
Reheating	60 min	60 min	60 min	60 min	60 min	60 min
Total time	02:50	02:55	03:00	02:50	02:55	03:00
Time for addition of dried fruit, nuts, etc.	02:15	02:19	02:23	02:15	02:19	02:23

Bread Maker

SBR 1031WH / SBR 1032SS

EN

Program	4 – Cake					
	Light			Darker		
Baking level	450 g	700 g	900 g	450 g	700 g	900 g
Weight	450 g	700 g	900 g	450 g	700 g	900 g
Delayed start	-	-	-	-	-	-
Preheating	-	-	-	-	-	-
Kneading 1	-	-	-	-	-	-
Resting	-	-	-	-	-	-
Kneading 2	21 min	22 min	23 min	21 min	22 min	23 min
Rising 1	-	-	-	-	-	-
Creation of an opening	-	-	-	-	-	-
Rising 2	19 min	23 min	28 min	19 min	23 min	28 min
Baking	50 min	55 min	59 min	50 min	55 min	59 min
Reheating	60 min	60 min	60 min	60 min	60 min	60 min
Total time	01:30	01:40	01:50	01:30	01:40	01:50
Time for addition of dried fruit, nuts, etc.	-	-	-	-	-	-

Program	5 – Whole wheat					
	Light			Dark		
Crust colour	450 g	700 g	900 g	450 g	700 g	900 g
Weight	450 g	700 g	900 g	450 g	700 g	900 g
Delayed start	0–10 h	0–10 h	0–10 h	0–10 h	0–10 h	0–10 h
Preheating	-	-	-	-	-	-
Kneading 1	15 min	15 min	15 min	15 min	15 min	15 min
Resting	21 min	23 min	25 min	21 min	23 min	25 min
Kneading 2	15 min	15 min	15 min	15 min	15 min	15 min
Rising 1	42 min	42 min	42 min	42 min	42 min	42 min
Creation of an opening	1 min	1 min	1 min	1 min	1 min	1 min
Rising 2	58 min	59 min	61 min	58 min	59 min	61 min
Baking	53 min	57 min	61 min	53 min	57 min	61 min
Reheating	60 min	60 min	60 min	60 min	60 min	60 min
Total time	03:25	03:32	03:40	03:25	03:32	03:40
Time for addition of dried fruit, nuts, etc.	02:39	02:44	02:55	02:39	02:44	02:55

Program	6 – Sandwich					
	Light			Dark		
Crust colour	450 g	700 g	900 g	450 g	700 g	900 g
Weight	450 g	700 g	900 g	450 g	700 g	900 g
Delayed start	0–10 h	0–10 h	0–10 h	0–10 h	0–10 h	0–10 h
Preheating	-	-	-	-	-	-
Kneading 1	15 min	15 min	15 min	15 min	15 min	15 min
Resting	38 min	39 min	40 min	38 min	39 min	40 min
Kneading 2	5 min	5 min	5 min	5 min	5 min	5 min
Rising 1	37 min	37 min	37 min	37 min	37 min	37 min
Creation of an opening	1 min	1 min	1 min	1 min	1 min	1 min
Rising 2	27 min	27 min	27 min	27 min	27 min	27 min
Baking	52 min	56 min	60 min	52 min	56 min	60 min
Reheating	60 min	60 min	60 min	60 min	60 min	60 min
Total time	02:55	03:00	03:05	02:55	03:00	03:05
Time for addition of dried fruit, nuts, etc.	-	-	-	-	-	-

Bread Maker

SBR 1031WH / SBR 1032SS

Program	7 – Kneading
Crust colour	-
Weight	-
Delayed start	-
Preheating	-
Kneading 1	10 min
Resting	-
Kneading 2	-
Rising 1	-
Creation of an opening	-
Rising 2	-
Baking	-
Reheating	-
Total time	10 min
Time for addition of dried fruit, nuts, etc.	-

Program	8 – Jam
Crust colour	-
Weight	-
Delayed start	-
Preheating	-
Kneading 1	-
Rising 1 (cooking)	15 min
Kneading 2	-
Rising 2 (cooking)	45 min
Creation of an opening	-
Rising 3 (cooking)	20 min
Baking	-
Reheating	-
Total time	01:20
Time for addition of dried fruit, nuts, etc.	-

Program	9 – Yogurt (Yogurt bread)					
	Light			Dark		
Crust colour	450 g	700 g	900 g	450 g	700 g	900 g
Delayed start	0–10 h	0–10 h	0–10 h	0–10 h	0–10 h	0–10 h
Preheating	-	-	-	-	-	-
Kneading 1	15 min	15 min	15 min	15 min	15 min	15 min
Resting	19 min	21 min	23 min	19 min	21 min	23 min
Kneading 2	15 min	15 min	15 min	15 min	15 min	15 min
Rising 1	44 min	44 min	44 min	44 min	44 min	44 min
Creation of an opening	1 min	1 min	1 min	1 min	1 min	1 min
Rising 2	50 min	50 min	50 min	50 min	50 min	50 min
Baking	56 min	59 min	62 min	56 min	59 min	62 min
Reheating	60 min	60 min	60 min	60 min	60 min	60 min
Total time	03:20	03:25	03:30	03:20	03:25	03:30
Time for addition of dried fruit, nuts, etc.	02:36	02:39	02:42	02:36	02:39	02:42

Program	10 – Dough	11 – Fast bake	12 – Bake
Crust colour	-	-	-
Weight	-	-	-
Delayed start	-	-	-
Preheating	-	-	-
Kneading 1	15 min	12 min	-
Resting	10 min	5 min	-
Kneading 2	10 min	5 min	-
Rising 1	-	-	-
Creation of an opening	-	-	-
Rising 2	55 min	14 min	-
Baking	-	54 min	60 min
Reheating	-	60 min	60 min
Total time	01:30	01:30	01:00
Time for addition of dried fruit, nuts, etc.	--	-	-

BREAD BAKING

Brief description of most commonly used ingredients for baking bread

1) **Bread flour**

Bread flour has a high gluten content (therefore we can call it high gluten flour, which contains a high amount of proteins), it has good elastic properties and after rising it is able to hold the bread up so that it does not collapse. Because the gluten content is higher than in normal flour it is possible to use it for baking larger size breads with better internal fibres. Bread flour is the most important ingredient when baking bread.

2) **Plain flour**

Plain flour is made of carefully selected hard and soft wheat and it is suitable for fast bread baking or for cake and pastry baking.

3) **Whole wheat flour**

Whole wheat flour is made by milling wheat and contains wheat husks and gluten. Whole wheat flour is heavier and more nutritious than regular flour. Bread baked from whole wheat flour is usually smaller. That is why most recipes combine whole wheat with bread flour in order to achieve the best results.

4) **Black wheat flour**

Black wheat flour also called "wholemeal flour" is a type of flour with a high fibre content, similar to whole grain flour. To achieve bigger sizes after rising it is necessary to use in combination with a high amount of bread flour.

5) **Rye flour**

Rye flour is intended primarily for baking dark bread. It contains a large amount of mineral compounds. It has less gluten than wheat flour and for this reason it is usually used in combination with wheat flour.

6) **Baking powder**

Baking powder is made by milling fine wheat or wheat with a low protein content and is used especially for baking cakes. The various types of flour look similar, the effectiveness of yeasts or the absorption capacity of various types of flour vary significantly depending on where they are grown, growth conditions, milling processes and storage conditions. Try various brands of flour available on the market, taste them and compare the results - then select the flour, which according to your experience brings the best results.

7) **Corn flour and oat flour**

Corn flour and oat flour are made by milling corn and oats. Both are supplementary ingredients for baking a rougher bread and are used to improve the taste and structure of the bread.

8) **Sugar**

Sugar is a very important ingredient for achieving a sweet taste and bread colour. White sugar helps bread to rise and is used widely as a nutritional element. In special cases brown sugar, powder sugar or candy floss may be used.

9) **Yeast**

Yeast supports the dough rising process and produces carbon dioxide, which helps the bread increase its volume and makes the internal fibres finer. Quick rising, however, requires carbohydrates in the sugar and flour.

1 teaspoon of dry active yeast = 3/4 teaspoon of instant yeast

5 teaspoons of dry active yeast = 1 table spoon of instant yeast

2 teaspoons of dry active yeast = 1.5 teaspoons of instant yeast

Yeast must be stored in the refrigerator because high temperatures would spoil it; check the used-by date before using it. After each use, place them back in the refrigerator as soon as possible. The inability of bread to rise is usually the result of dead yeast.

**Tip:**

With the help of the procedure described below you can find out whether your yeast is fresh and active or not:

1. Into a measuring cup pour 1/2 cup of warm water (45-50 °C).
2. Add 1 teaspoon of white sugar and stir it. Then sprinkle it with 2 teaspoons of yeast.
3. Place the measuring cup in a warm place for about 10 minutes. Do not stir the mixture.
4. The foam should reach the edge of the measuring cup. If this does not occur, the yeast is dead or inactive.

10) Salt

Salt is necessary for improving the aroma of the bread and the colour of the crust. At the same time salt prevents yeast from working. Never use too much salt in a recipe. If you do not wish to use salt, you may leave it out. And the bread will be larger than if salt was used.

11) Eggs

Eggs can improve the structure of the bread, make the bread more nutritious and larger and add a specific egg aroma to the bread. If you wish to use eggs, you need to remove the egg shell and mix evenly.

12) Fat, butter and vegetable oil

Fat can make bread finer and keep it fresh for longer. Before butter is used it should be melted or cut into small pieces after being taken out of the fridge so that it is evenly mixed in.

13) Baking powder

Baking powder is used primarily for rising when baking bread and cakes in the Ultra Fast (Very fast baking) program. Thanks to chemical principles it does not need time for rising and creates a gas that creates bubbles or makes the structure of the bread finer.

14) Sodium bicarbonate

The same applies as for baking powder. It can also be used in combination with baking powder.

15) Water and other liquids

Water is a necessary ingredient for bread making. Generally, the most suitable water temperature is in the 20-25 °C range. For rising in accelerated programs, the water temperature should be in the 45-50 °C range. Instead of water, you can use fresh milk or water mixed with 2% milk power, which can improve the aroma of the bread and create a nicer crust colour. In some recipes in order to improve the aroma of the bread, juice may be used (e.g. apple, orange, lemon, etc.).

Sequence of adding ingredients

In all recipes it is important to follow a general sequence when adding individual ingredients:

- First we add liquids into the baking container (water, milk, beer, butter milk, clabbered milk, yoghurt, eggs, etc.)
- Then we add loose ingredients (flour, herbs, bread spices, bran, sprouts, flakes, seeds, etc.)
- Pour the salt into one corner
- Pour sugar into the second corner
- Pour spices into another
- In the middle of the baking container make a small hole, place the yeast or baking powder into it and cover it with flour. If fresh yeast is used, it is better to add sugar directly with the yeast. Place the yeast or baking powder always on dry flour!

**Tip:**

To achieve better results with heavy dough containing a high portion of rye flour or whole wheat components, we recommend to reverse the sequence of ingredients, i.e. first add the dry yeast and flour and then the liquids.

- We only add dried fruit, nuts, etc. during the Kneading 2 stage after the bread maker makes a sound (10 beeps). This function is only available with some programs.

Remember a few more important points for baking in a home bread maker:

- Salt and yeast must never come into direct contact!
- Let cereals soak in water over night before baking.
- In the case of a delayed start, always use cold ingredients
- When baking with a delayed start, do not use ingredients that spoil quickly such as eggs, fresh milk, fruit, onions, etc.
- After taking the bread out of the bread maker allow it to cool on a suitable surface (e.g. on a wooden or nylon cutting board).

RECIPES



Attention:

Please take all the weights, volumes and contents of all individual ingredients in the recipes below only as a guide. Baking results depend on many factors:

- the hardness of the water (when using water that is too soft the dough rises faster)
- air humidity in the kitchen (in the case of higher humidity, it is necessary to decrease the amount of water by 1 - 2 table spoons)
- above sea level altitude (at an altitude above 750 m above sea level the dough rises faster)
- the consistency of the ingredients

For the above mentioned reasons, we recommend that you modify the chosen recipe to your given conditions depending on the current conditions.

Standard accessories of the bread maker include a measuring spoon and measuring cup. The measuring spoon is double sided with a small and large end. The capacity of the small measuring spoon is 5 ml. The capacity of the large measuring spoon is 15 ml. The measuring cup has a capacity of 250 ml.

One levelled measuring cup is equivalent to 150 g of flour or 250 ml of water.

One levelled small measuring spoon is equivalent to 6 g of salt, 3.5 g of dried yeast, 4.5 g of flour improver, 3.5 g of cream of tartar or 6 g of potassium bicarbonate.

One levelled large measuring spoon is equivalent to 14 g of sugar, 7 g of raisins, 6 g of nuts, 6.5 g of dried milk, 16 g of oil. One whole egg weighs approximately 50 to 60 g.

When measuring out ingredients, have the measuring spoon/cup placed on an even surface. You can check the precise amount of liquids when the measuring spoon/cup is at your eye level.



Tip:

If for any reason you do not want to bake bread using the recipes, you can purchase ready-made bread mixes at your grocery store. With ready-mixes always follow the instructions on the pack. Please be aware that even these purchased ready-mixes from some producers require the addition of yeast as a separate ingredient.

Basic bread recipe

Ingredients:

340 ml of water

1 small measuring spoon of salt

3 large measuring spoons of white sugar

2 large measuring spoons of vegetable oil

3 $\frac{3}{4}$ measuring cups of bread flour

2 $\frac{1}{2}$ large measuring spoons of dried low-fat milk

2 small measuring spoons of flour improver

1 $\frac{1}{4}$ small measuring spoons of dried yeast

Bread maker settings: Program 1 – BASIC (standard baking), loaf size: 900 g, crust: select LIGHT or DARK according to taste

French bread**Ingredients:**

- 340 ml of water
- 1 ½ small measuring spoons of salt
- 2 ½ large measuring spoons of white sugar
- 1 ¼ large measuring spoons of vegetable oil
- 3 ¾ measuring cups of bread flour
- 2 ½ large measuring spoons of dried low-fat milk
- 2 small measuring spoons of flour improver
- 1 ¼ small measuring spoons of dried yeast

Bread maker settings: Program 2 – FRENCH (French bread), loaf size: 900 g, crust: select LIGHT or DARK according to taste

Sweet bread**Ingredients:**

- 240 ml of water
- 2 egg
- ½ measuring cup of white sugar
- ½ small measuring spoon of salt
- 1 ½ large measuring spoons of vegetable oil
- 3 measuring cups of bread flour
- 2 ½ large measuring spoons of dried low-fat milk
- 2 small measuring spoons of flour improver
- 1 small measuring spoon of dried yeast

Bread maker settings: Program 3 – SWEET (sweet bread), loaf size: 900 g, crust: select LIGHT or DARK according to taste

Cake**Ingredients:**

- 4 egg
- 80 ml of milk
- 1 large measuring spoon of melted butter
- ½ small measuring spoon of salt
- 2 ½ large measuring spoons of brown sugar
- 3 ¾ measuring cups of flour
- 1 ½ small measuring spoons of cream of tartar (potassium bitartrate)
- ½ small measuring spoons of sodium bicarbonate
- 2 large measuring spoons of dried yeast

**Note:**

First whip the egg separately and only then add it to the other ingredients in the baking container.

Bread maker settings: Program 4 – CAKE (cake), loaf size: 900 g, baking level: select LIGHT or DARK according to taste

Whole grain bread**Ingredients:**

- 340 ml of water
- 1 small measuring spoon of salt
- 2 ½ large measuring spoons of white sugar
- 1 ½ large measuring spoons of vegetable oil
- 1 ¾ measuring cups of whole wheat flour
- 2 measuring cups of bread flour
- 2 large measuring spoons of dried low-fat milk
- 2 small measuring spoons of flour improver

1 ¼ small measuring spoons of dried yeast

Bread maker settings: Program 5 – WHOLE WHEAT (whole wheat bread), loaf size: 900 g, crust: select LIGHT or DARK according to taste

Sandwich bread

Ingredients:

260 ml of water

1 egg

½ small measuring spoon of salt

2 ½ large measuring spoons of white sugar

2 large measuring spoons of vegetable oil

3 ½ measuring cups of bread flour

2 large measuring spoons of dried low-fat milk

2 small measuring spoons of flour improver

1 ¼ small measuring spoons of dried yeast

Bread maker settings: Program 6 – SANDWICH (toast bread), loaf size: 900 g, crust: select LIGHT or DARK according to taste

Yoghurt bread

Ingredients:

150 ml of water

200 g of yoghurt

2 ½ large measuring spoons of white sugar

⅔ small measuring spoons of salt

2 large measuring spoons of vegetable oil

3 ¾ measuring cups of bread flour

2 small measuring spoons of flour improver

1 ¼ small measuring spoons of dried yeast

Bread maker settings: Program 9 – YOGURT (yoghurt bread), loaf size: 900 g, crust: select LIGHT or DARK according to taste

Fine graham bread

Ingredients:

350 ml of water

3 large measuring spoons of oil

2 small measuring spoons of salt

1 small measuring spoon of caraway seed

1 large measuring spoon of dried milk

300 g of fine flour

100 g of rye flour

100 g of graham flour

1 small measuring spoon of dry yeast or 1/4 of fresh yeast

Bread maker settings: Program BASIC (standard baking) / size 900 g / crust LIGHT

White caraway bread

Ingredients:

300 ml of water

2 small measuring spoons of sugar

2 small measuring spoons of salt

1 small measuring spoon of caraway seed

500 g of fine flour

1 small measuring spoon of dry yeast or 1/4 of fresh yeast

Bread maker settings: Program BASIC (standard baking) / size 900 g / crust DARK

Beer bread

Ingredients:

250 ml of beer
100 ml of water
2.5 small measuring spoons of ground caraway seed
2 small measuring spoons of salt
350 g of fine flour
150 g of wheat bread flour
1 small measuring spoon of dry yeast or 1/4 of fresh yeast
seeds according to taste (e.g. sunflower seeds)
Bread maker settings: Program BASIC (standard baking) / size 900 g / crust DARK

Spelt bread

Ingredients:

350 ml of buttermilk
50 ml of water
1 large measuring spoon of vinegar
2 large measuring spoons of olive oil
1 small measuring spoon of salt
1 small measuring spoon of sugar
250 g of fine flour
250 g of whole wheat spelt flour
1 small measuring spoon of dry yeast or 1/4 of fresh yeast
shelled sunflower seeds according to taste
Bread maker settings: Program BASIC (standard baking) / size 900 g / crust DARK

Šumava bread

Ingredients:

320 ml of water
1 large measuring spoon of vinegar
2 large measuring spoons of oil
2 small measuring spoon of caraway seed
2.5 small measuring spoons of salt
220 g of fine flour
230 g of wheat bread flour
100 g of whole wheat flour
1 small measuring spoon of dry yeast or 1/4 cube of fresh yeast
2 large measuring spoons of sunflower seeds
Bread maker settings: BASIC (standard baking) / size 900 g / crust DARK

Bacon bit bread

Ingredients:

200 ml of buttermilk (or sour cream)
150 ml of water (possible to add depending on the thickness of the buttermilk)
1 large measuring spoon of vinegar
1 rounded tablespoon of milled pork crackle
1.5 small measuring spoons of salt
1 small measuring spoon of sugar
1 small measuring spoon of caraway seed
150 g of wholegrain rye flour
350 g of fine flour
1 1/4 small measuring spoons of dry yeast or 1/4 cube of fresh yeast
Bread maker settings: Program BASIC (standard baking) / size 900 g / crust DARK

Sunflower bread

Ingredients:

- 330 g of water
- 2 large measuring spoons of oil
- 1 large measuring spoon of vinegar
- 280 g of fine flour
- 120 g of fine wholegrain flour
- 60 g of spelt flour
- 80 g of wheat bread flour
- 2 small measuring spoons of salt
- 1 small measuring spoon of dry yeast or 1/4 cube of fresh yeast
- 5 large measuring spoons of shelled sunflower seeds

Bread maker settings: Program BASIC (standard baking) / size 900 g / crust DARK

Bacon-garlic bread

Ingredients:

- 320 ml of water
- 2 large measuring spoons of oil
- 1 large measuring spoon of vinegar
- 1,5 small measuring spoons of salt
- 1 small measuring spoon of sugar
- 2 small measuring spoons of dried mashed potatoes
- 1 small measuring spoon of dried garlic (or 1-2 cloves)
- 1 small measuring spoon of caraway seed
- 3 large measuring spoons of finely diced or milled pork crackle
- 350 g of fine flour
- 150 g of rye flour
- 1 small measuring spoon of dry yeast or 1/4 cube of fresh yeast

Bread maker settings: Program BASIC (standard baking) / size 900 g / crust DARK

Bread with honey and sunflower seeds

Ingredients:

- 280 ml of water
- 15 g of butter
- 1 large measuring spoon of dried milk
- 1 small measuring spoon of salt
- 1,5 small measuring spoons of honey
- 200 g of light flour
- 200g Granary flour (wholegrain flour with the addition of ground wheat and rye grains)
- 1/2 small measuring spoons of dry yeast or half a 1/4 cube of fresh yeast
- 2 large measuring spoons of shelled sunflower seeds

Bread maker setting: Program BASIC (standard baking) / size 700 g / crust DARK

Banana bread

Ingredients:

- 6 large measuring spoons of milk
- 200 g of bananas (purée or mashed with a fork)
- 1 egg
- 70 g of melted butter
- 70 g of sugar
- 450 g of fine flour
- 1 small measuring spoon of dry yeast or 1/4 cube of fresh yeast

Bread maker settings: Program BASIC (standard baking) / size 900 g / crust LIGHT

Leek bread with cheese**Ingredients:**

200 ml of water
2 small measuring spoons of oil
1 whipped egg
150 g of cottage cheese
200 g of semi-fine flour
100 g of spelt flour
100 g of wholegrain rye flour
100 g of wheat bread flour
2 small measuring spoons of salt
1 small measuring spoon of sugar
2 small measuring spoons of dry yeast or 1/2 cube of fresh yeast
After the sound is made during the Kneading 2 stage, add 1 small leek

Bread maker settings: Program BASIC (standard baking) / size 900 g / crust DARK

Cheese bread with ketchup**Ingredients:**

200 ml of lukewarm water
1 whipped egg
1 large measuring spoon of olive oil
4 large measuring spoons of ketchup
1 small measuring spoon of salt
1/4 small measuring spoon of ground black pepper
300 g of wheat bread flour
100 g of rye bread flour
100g of spelt flour
1 small measuring spoon of dry yeast or 1/4 cube of fresh yeast
After the sound is made during the Kneading 2 stage, add 250 g of grated Edam cheese

Bread maker settings: Program BASIC (standard baking) / 900 g / crust DARK

Old Bohemian bread**Ingredients:**

230 ml of water
1 large measuring spoon of vinegar
2 small measuring spoons of salt
75 g boiled potatoes
450 g of fine bread flour
1 small measuring spoon of ground caraway seed
1/4 small measuring spoon of ground fennel
1/4 small measuring spoon of ground aniseed
1/4 small measuring spoon of ground coriander
1 small measuring spoon of sugar
1 small measuring spoon of dry yeast or 1/4 cube of fresh yeast

Bread maker settings: Program BASIC (standard baking) / size 900 g / crust DARK

Olive and oregano bread**Ingredients:**

300 ml of lukewarm water
sprinkle of sugar
1 small measuring spoon of salt
1 large measuring spoon of olive oil
1 diced onion
540 g of fine flour
1 small measuring spoon of dry yeast or 1/4 cube of fresh yeast
1/4 small measuring spoon of freshly ground black pepper

50 g roughly sliced black olives without stones

1 large measuring spoon of fresh chopped oregano (or 1 teaspoon of dried oregano)

1 large measuring spoon of fresh chopped parsley

Procedure: Fry the onion on oil until golden. Into the container put water, fried onion with oil, flour, spices, sugar, salt and yeast. We add olives only after the sound is made during the Kneading 2 stage.

Bread maker settings: Program BASIC (standard baking) / size 900 g / crust DARK

Herb bread with buttermilk

Ingredients:

110 ml of lukewarm water

150 ml of buttermilk

1 small measuring spoon of sugar

2 small measuring spoons of salt

pepper

3 large measuring spoons of oil

250 g of fine flour

250 g of semi-fine flour

1 small measuring spoon of dry yeast or 1/4 cube of fresh yeast

2 large measuring spoons of parsley

2 large measuring spoons of chives

2 large measuring spoons of dill

Bread maker settings: Program BASIC (standard baking) / size 900 g / crust DARK

Bread with Olomoucké tvarůžky cheese

Ingredients:

300 ml of water

1 large measuring spoon of olive oil

2 egg whites or 1 whole egg

4 large measuring spoons of ketchup

1 small measuring spoon of salt

300 g of wheat bread flour

100 g of spelt flour

70 g of fine flour

1 small measuring spoon of dry yeast or 1/4 cube of fresh yeast

50 g of bran

170 g of roughly grated "olomoucké tvarůžky" cheese

Bread maker settings: Program BASIC (standard baking) / 900 g / crust DARK

Garlic bread with vegetables

Ingredients:

375 ml of water

2 large measuring spoons of olive oil

2 large measuring spoons of balsamic vinegar

2 small measuring spoons of salt

1 small measuring spoon of sugar

3 small measuring spoons of dried garlic

2 small measuring spoons of herbes de Provence

2 large measuring spoons of linseed

200 g of fine wheat flour

100 g of whole wheat flour

100 g of spelt wheat flour

200 g of rye bread flour

1,5 small measuring spoons of dry yeast or not full 1/2 cube of fresh yeast

Filling:

sterilised peas

Bread Maker

SBR 1031WH / SBR 1032SS

fresh leek chopped into circles
red pepper, young onion, dried tomatoes, etc.

Procedure: Place the basic ingredients in the bread maker as usual. Put the herbs and garlic directly into the water, mix the linseeds directly into the flour. After the last kneading take the dough out of the bread maker, remove the kneading blade (i.e. blades) and work the contents into the dough. Then insert the mix quickly back into the bread maker for the final kneading.

Bread maker settings: Program BASIC (standard baking) / size 900 g / crust DARK

Bean bread

Ingredients:

300 ml of water
2 large measuring spoons of wheat bran
2 large measuring spoons of linseed
1 large measuring spoon of salt
1 small measuring spoon of ground caraway seed
400 g of fine flour
100 g of rye bread flour
1/4 of fresh yeast (+ 1 tablespoon of sugar) or 1 teaspoon of dry yeast
150 g fresh beans from the can

Procedure: Add the beans after the kneading process is finished. As soon as the rising stage starts, take the dough out of the bread maker (leave the bread maker closed and on), roll out the dough, sprinkle with the drained beans and roll it up. Take out the kneading blade (blades) and return the dough back into the bread maker.

Bread maker settings: Program BASIC (standard baking) / size 900 g / crust DARK

Dark bread with Csabai sausage

Ingredients:

400 ml of water
1 large measuring spoon of vinegar
2 large measuring spoons of sour dough
250 g of wholegrain wheat flour special
150 g of dark rye bread flour
180 g of wheat bread flour
1 large measuring spoon of caraway seed
2 large measuring spoons of linseed
1 small measuring spoon of dried garlic
1 small measuring spoon of sugar
2 small measuring spoons of salt
1 small measuring spoon of dry yeast or 1/4 cube of fresh yeast

Procedure: 5 minutes before the end of the kneading, add 1/2 a Csabai sausage roughly grated and a handful of fresh chives. Then shred 50 g of hard Koliba cheese and add it to the dough.

Bread maker settings: Program BASIC (standard baking) / size 900 g / crust DARK

Garlic bread with blue cheese

Ingredients:

350 ml of water
1 small measuring spoon of salt
1 small measuring spoon of sugar
1.5 large measuring spoons of oil
1/2 of a cup of crushed blue cheese
4 - 5 crushed cloves of garlic
140 g of fine flour
200 g of whole wheat flour
200 g of wholegrain rye flour
1 small measuring spoon of dry yeast or 1/4 cube of fresh yeast

Bread maker settings: Program WHOLEWHEAT / size 900 g / crust DARK

Dark chocolate bread

Ingredients:

400 ml of water

4 large measuring spoons of icing sugar

1.5 small measuring spoons of salt

400 g of fine wheat flour

100 g of cocoa powder

2 small measuring spoons of dry yeast or 1/2 cube of fresh yeast

Bread maker settings: Program BASIC (standard baking) / size 900 g / crust DARK

MARMALADE MAKING RECIPE

Ingredients:

500 g of fruit

165 g of gelatine sugar

1 small measuring spoon of lemon juice

Procedure:

Clean the fruit thoroughly, depending on type peel it (e.g. peach), remove the stones (e.g. cherries), and mix in a mixer. Then pour the mix into the baking container, add the other ingredients and start the program. After the program finishes, pour the marmalade into jars, which were sterilized for 20 minutes in the oven at 150°C beforehand. Then we put the lids on and turn the jars upside down so that the lids gain hold.

Bread maker settings: Program JAM

BAKING TROUBLESHOOTING GUIDE

No.	Problem	Cause	Solution
1.	Smoke is escaping from the vents during baking.	Some elements got stuck to the heating element or got near it. On first use this may be oil that remained on the surface of the heating element	Disconnect the bread maker from the power supply and clean the heating element. Use caution to prevent burns. On first use dry by operation and open the lid.
2.	The bottom crust is too thick.	You are using the function for maintaining the heat of the bread and are leaving the bread too long in the baking container so it is becoming overly dehydrated	Take out the bread sooner, do not use the function for keeping the bread warm.
3.	It is very difficult to take out the bread	The kneading blade is stuck to the shaft inside the baking container.	After you remove the bread, fill the baking container with warm water and submerge the kneading blade in it for about 10 minutes, then take it out and clean it.
4.	The ingredients are not evenly mixed and are incorrectly baked.	1. Incorrectly selected program.	Select the correct program
		2. After starting a program you have opened the lid several times and the bread is dry and does not have a brown crust	Do not open the lid during the last rising period.
		3. The resistance during mixing is too high, so the mixing blade barely turns and does not mix sufficiently	Inspect the hole in the kneading blade. Remove the baking container and turn on the kneading process without the dough. If the appliance does not seem to work properly, contact authorized service centre.
5.	You can hear the motor running but the dough is not being kneaded.	The baking container is incorrectly attached or the dough is too large for mixing	Check whether the baking container is correctly attached, whether the dough is prepared according to the recipe and whether the ingredients have the right weight.
6.	The bread is so large that it presses of the lid	Too much yeast, dough or water, or the ambient temperature is too high.	Check the above mentioned factors, reduce by the relevant amount the ingredients or the temperature.
7.	The bread is too small or rising didn't occur	No yeast or not enough yeast, or yeast that is not active because of excessive temperature of the water or the yeast was mixed with salt or the ambient temperature is too low.	Check the amount and activity of the yeast, increase in the relevant manner the ambient temperature.
8.	The dough is too big and pours out of the baking container	Too much liquid makes the dough fine and also too much yeast.	Reduce the amount of liquids and improve the toughness of the yeast

Bread Maker

SBR 1031WH / SBR 1032SS

EN

No.	Problem	Cause	Solution
9.	While baking the dough the bread collapses inside	1. The flour used does not have the proper composition and is not able to cause the dough to rise.	Use bread flour or strong powder.
		2. The rising process is too quick or the yeast temperature is too high.	Yeast should be used at lower temperatures than the surrounding room temperature.
		3. Too much water makes the dough too watery or too fine.	According to the ability to absorb water modify the amount of water in the recipe
10.	The bread is too heavy and its structure is too dense	1. Too much flour or not enough water	Reduce the amount of flour or increase the amount of water
		2. Too much fruit ingredients or too much wholegrain flour	Reduce the among of the relevant ingredients and increase the amount of yeast
11.	After the bread is sliced, the middle slices are hollow	1. Too much water, too much yeast or not enough salt.	In the relevant manner lower the amount of water or yeast and check whether salt was added
		2. Water temperature is too high.	Check the water temperature.
12.	Dry powder is stuck to the bread surface.	1. The bread contains strong gelatinous ingredients such as butter and bananas, etc.	Do not add strong gelatinous ingredients.
		2. Because of the lack of water mixing is not sufficient	Check the water and the mechanical construction of the bread maker
13.	While baking cakes or meals with a high sugar content the crust is too thick and the crust is too dark	Various recipes or ingredients have a large effect on bread making, the colour of the crust is dark because of the large sugar content	If the crust colour with a recipe with a large amount of sugar is too dark, press the Start/Stop button to stop the program 5-10 minutes before the planned end of the program. Before taking the bread or cake out of the baking container you should leave the bread in the baking container for approximately 20 minutes with the lid closed
14.	When the START/ STOP button is pressed, "H:HH" will appear on the display and a sound will be made (5 beeps)	The temperature inside the bread maker is too high	Press the "START/STOP" button and hold it pressed down until you hear a beep. Disconnect the bread maker from the el. power socket and open the lid. Take out the baking container and before starting again allow the bread maker to cool down first.

TECHNICAL SPECIFICATIONS

Nominal voltage range.....	220–240 V
Nominal frequency.....	50 Hz
Rated power input.....	480–580 W
Noise level.....	65 dB(A)

The declared noise emission level of the appliance is 65 dB(A), which represents a level A of acoustic power with respect to a reference acoustic power of 1 pW.

Amendments to text and technical parameters are reserved.

INSTRUCTIONS AND INFORMATION REGARDING THE DISPOSAL OF USED PACKAGING MATERIALS

Dispose of used packaging material at a site designated for waste in your municipality.

DISPOSAL OF USED ELECTRICAL AND ELECTRONIC EQUIPMENT



This symbol on products or original documents means that used electric or electronic products must not be added to ordinary municipal waste. For proper disposal, renewal and recycling hand over these products to determined collection points. Or as an alternative in some European Union states or other European countries you may return your products to the local retailer when buying an equivalent new product.

Correct disposal of this product helps save valuable natural resources and prevents damage to the environment caused by improper waste disposal. Ask your local authorities or collection facility for more details.

In accordance with national regulations penalties may be imposed for the incorrect disposal of this type of waste.

For business entities in European Union states

If you want to dispose of electric or electronic appliances, ask your retailer or supplier for the necessary information.

Disposal in other countries outside the European Union

This symbol is valid in the European Union. If you wish to dispose of this product, request the necessary information about the correct disposal method from the local council or from your retailer.



This product meets all the basic requirements of EU directives that apply to it.