

PRO-FORM® CROSS WALK

DUAL • MOTION • CROSS • TRAINER

SEARS

Model No. 831.297231

Serial No. _____

The serial number can be found in the location shown below. Write the serial number in the space above.

Serial
Number
Decal

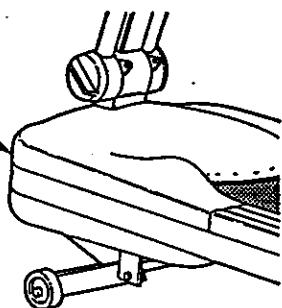

EXERCISE
EQUIPMENT

QUESTIONS

HELPLINE!

1-800-736-6879

CAUTION:

Read all precautions and instructions in this manual before using this equipment. Keep this manual for future reference.

OWNER'S MANUAL

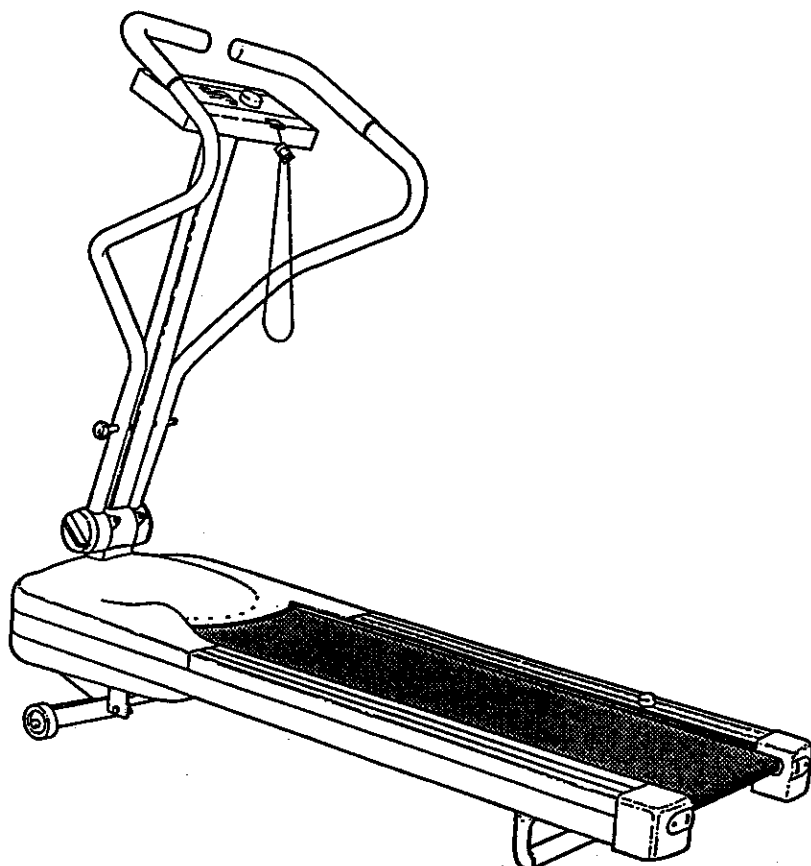

SEARS, ROEBUCK AND CO., HOFFMAN ESTATES, IL 60179

TABLE OF CONTENTS

FULL 90 DAY WARRANTY	2
IMPORTANT PRECAUTIONS	3
BEFORE YOU BEGIN	4
ASSEMBLY	5
OPERATION AND ADJUSTMENT	5
TROUBLE-SHOOTING AND MAINTENANCE	9
CONDITIONING GUIDELINES	11
PART LIST	14
EXPLODED DRAWING	15
ORDERING REPLACEMENT PARTS	Back Cover

FULL 90 DAY WARRANTY

For 90 days from the date of purchase, if failure occurs due to defect in material or workmanship in this SEARS TREADMILL EXERCISER, contact the nearest SEARS Service Center throughout the United States and SEARS will repair or replace the TREADMILL EXERCISER, free of charge.

This warranty does not apply when the TREADMILL EXERCISER is used commercially or for rental purposes.

This warranty gives you specific legal rights, and you may also have other rights which vary from state to state.

SEARS, ROEBUCK AND CO., DEPT. 817WA, HOFFMAN ESTATES, IL 60179

WARNING: Before beginning this or any exercise program, consult your physician. This is especially important for persons over the age of 35 or persons with pre-existing health problems. Read all instructions before using the CROSS WALK. SEARS assumes no responsibility for personal injury or property damage sustained by or through the use of the CROSS WALK.

IMPORTANT PRECAUTIONS

▲ WARNING: To reduce the risk of burns, fire, electric shock, or injury to persons, read the following important precautions and information before operating the CROSSWALK.

1. It is the responsibility of the owner to ensure that all users of this treadmill are adequately informed of all warnings and precautions.
2. Use the treadmill only as described in this manual.
3. Place the treadmill on a level surface, with eight feet of clearance behind it. Do not place the treadmill on any surface that blocks air openings. To protect the floor or carpet from damage, place a mat under the treadmill.
4. Keep the treadmill indoors, away from moisture and dust. Do not place the treadmill in a garage or covered patio, or near water.
5. Do not operate the treadmill where aerosol products are used or where oxygen is being administered.
6. Keep small children and pets away from the treadmill at all times.
7. The treadmill should be used only by persons weighing 250 pounds or less. Do not allow more than one person on the treadmill at a time.
8. When connecting the power cord (see HOW TO PLUG IN THE POWER CORD on page 6) plug the power cord into a surge protector (not included) and plug the surge protector into a grounded circuit capable of carrying 15 or more amps. No other appliance should be on the same circuit.
9. Use only a UL-listed surge protector, rated at 15 amps, with a 14-gauge cord of five feet or less in length. Do not use an extension cord.
10. Keep the power cord and the surge protector away from heated surfaces.
11. Never move the walking belt while the power is turned off. Do not operate the treadmill if the power cord or plug is damaged, or if the treadmill is not working properly. (See BEFORE YOU BEGIN on page 4 if the treadmill is not working properly.)
12. Wear appropriate clothing when using the treadmill; do not wear loose clothing that could become caught in the treadmill. Athletic support clothes are recommended for both men and women. Always wear athletic shoes; never use the treadmill with bare feet, wearing only stockings or in sandals.
13. Never start the treadmill while you are standing on the walking belt. Always hold the handrails or upper body arms while using the treadmill.
14. The treadmill is capable of high speeds. Adjust the speed in small increments to avoid sudden jumps in speed.
15. To reduce the possibility of the treadmill overheating, do not operate the treadmill continuously for longer than 1 hour.
16. Never leave the treadmill unattended while it is running. Always remove the key when the treadmill is not in use.
17. Never insert any object into any opening.
18. Inspect and tighten all parts of the treadmill every three months.
19. Always unplug the power cord before performing the maintenance and adjustment procedures described in this manual. Never remove the motor hood unless instructed to do so by an authorized service representative. Servicing other than the procedures in this manual should be performed by an authorized service representative only.

SAVE THESE INSTRUCTIONS

BEFORE YOU BEGIN

Congratulations for selecting the PROFORM® CROSS WALK Dual Motion Cross Trainer.

The CROSS WALK combines the best features of today's most popular home exercise equipment in one compact unit. The natural motion and versatility of treadmills have made them the most popular way to get an effective lower body and cardiovascular workout. Now with the dual motion design of the CROSS WALK, you can get a complete upper body workout as well. And the adjustability of the CROSS WALK allows every user to work at their own level. Whether you are a beginner or a seasoned athlete, you'll enjoy the performance and uncompromising quality that only the CROSS WALK offers.

For your benefit, read this manual carefully before using the CROSS WALK. If you have additional questions, please call our toll-free HELPLINE at 1-800-736-6879, Monday through Saturday, 7 a.m. until 7 p.m. Central Time (excluding holidays). To help us assist you, please note the product model number and serial number before calling. The model number is 831.297231. The serial number can be found on a decal attached to the CROSS WALK (see the drawing on the front cover for the location of the decal).

Before reading further, please review the drawing below and familiarize yourself with the parts that are labeled.

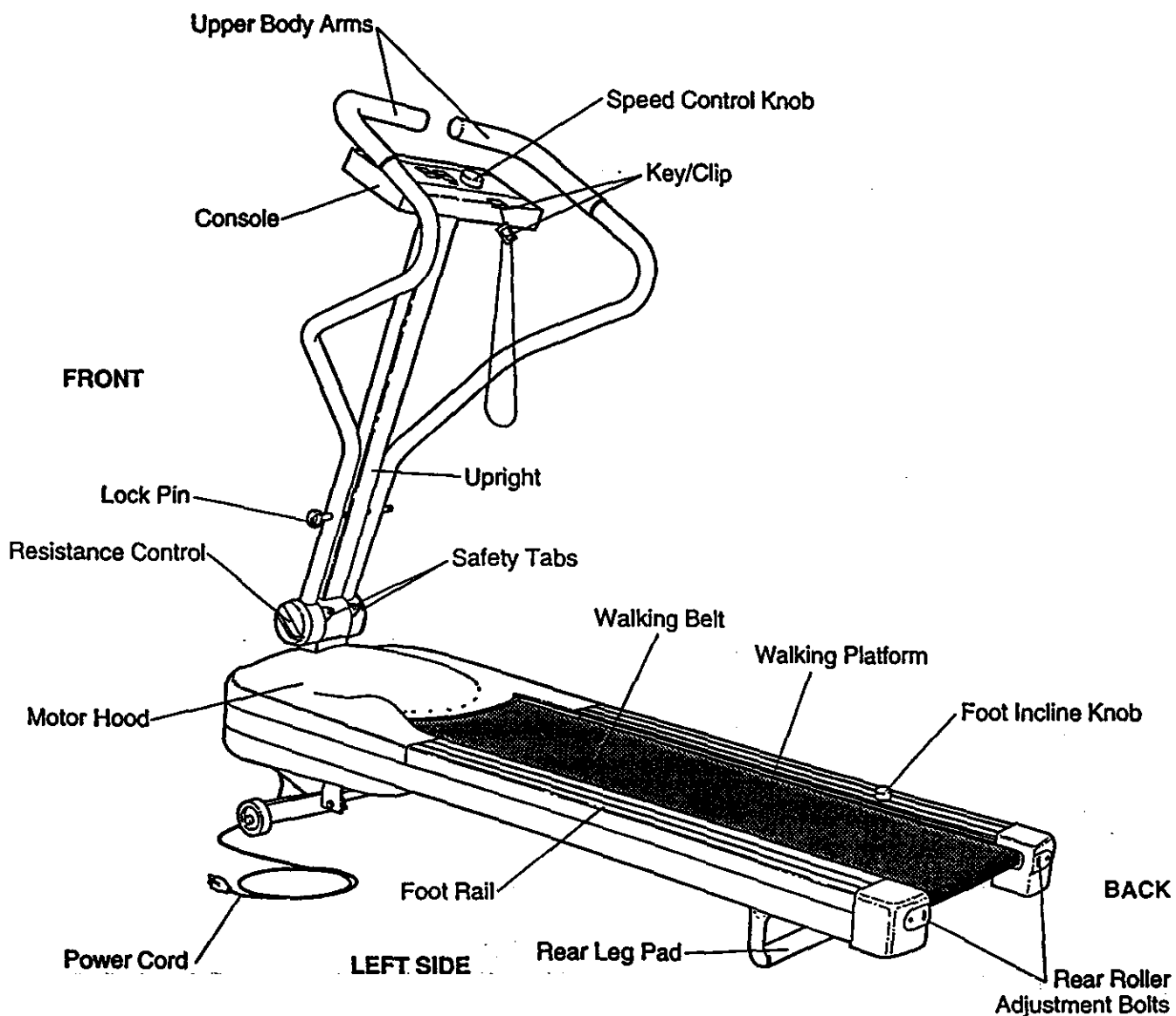

Note: The rear leg pad may mark some types of linoleum. Mild household cleaning agents will remove any marks.

ASSEMBLY

The CROSS WALK is shipped in the compact stowaway position. Set the CROSS WALK in a cleared area and remove all packing materials. Make sure that all parts have been removed before you dispose of the packing materials. Follow the instructions below to convert the CROSS WALK to the operating position. No tools are required.

1. Raise the Upright (10) to the vertical position. Slide the Lock Knob Washer (78) onto the Lock Knob (77) and tighten the Lock Knob into the Upright.

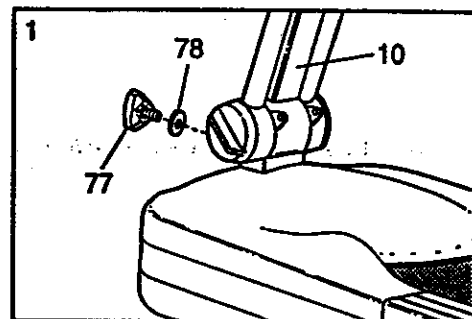

2. Remove the paper backing from the Wrench Clip (65). Press the Wrench Clip onto the Right Roller Bracket (62) in the indicated location. Press the Allen Wrench (66) into the Wrench Clip.

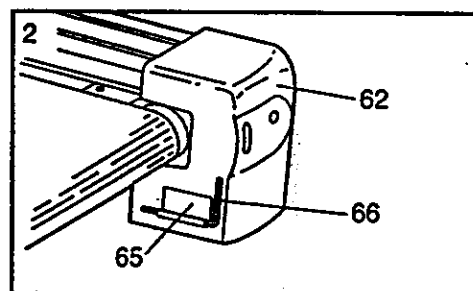

Make sure that all parts are tightened securely before you use the treadmill. The use of the remaining parts will be described in other sections of this manual. Note: To protect the floor or carpet from damage, place a mat under the treadmill.

OPERATION AND ADJUSTMENT

HOW TO INSTALL BATTERIES IN THE CONSOLE

The console requires two "AA" batteries (not included) for the motivational fitness monitor to operate; alkaline batteries are recommended.

To install batteries, first slide the battery cover open (see the drawing at the right). Remove the battery clip from the console. Find the markings inside the battery clip showing which direction the batteries should be turned. Press the batteries into the battery clip. Replace the battery clip in the console and close the battery cover.

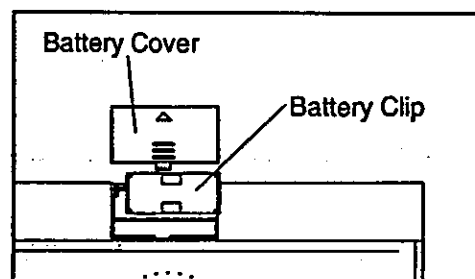

THE PERFORMANT LUBE™ WALKING BELT

Your treadmill features a walking belt coated with PERFORMANT LUBE™, a high-performance lubricant. **IMPORTANT:** Never apply silicone spray or other substances to the walking belt or the walking platform. They will deteriorate the walking belt and cause excessive wear.

HOW TO PLUG IN THE POWER CORD

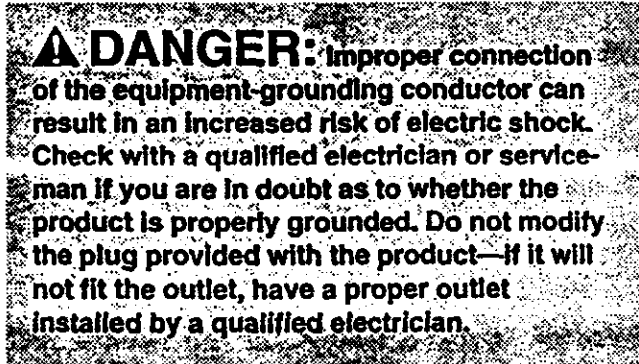

Your treadmill, like any other type of sophisticated electronic equipment, can be seriously damaged by sudden voltage changes in your home's power. Voltage surges, spikes, and noise interference can result from weather conditions or from other appliances being turned on or off. To decrease the possibility of your treadmill being damaged, always use a surge protector (not included) with your treadmill.

Surge protectors are sold at most hardware stores and department stores. Use only a UL-listed surge protector, rated at 15 amps, with a 14-gauge cord of five feet or less in length.

This product must be grounded. If it should malfunction or break down, grounding provides a path of least resistance for electric current to reduce the

risk of electric shock. This product is equipped with a cord having an equipment-grounding conductor and a grounding plug. Plug the power cord into a surge protector, and plug the surge protector into an appropriate outlet that is properly installed and grounded in accordance with all local codes and ordinances.

This product is for use on a nominal 120-volt circuit, and has a grounding plug that looks like the plug illustrated in drawing 1 below. A temporary adapter that looks like the adapter illustrated in drawing 2 may be used to connect the surge protector to a 2-pole receptacle as shown in drawing 2 if a properly grounded outlet is not available.

The temporary adapter should be used only until a properly grounded outlet (drawing 1) can be installed by a qualified electrician.

The green-colored rigid ear, lug, or the like extending from the adapter must be connected to a permanent ground such as a properly grounded outlet box cover. Whenever the adapter is used it must be held in place by a metal screw. Some 2-pole receptacle outlet box covers are not grounded. Contact a qualified electrician to determine if the outlet box cover is grounded before using an adapter.

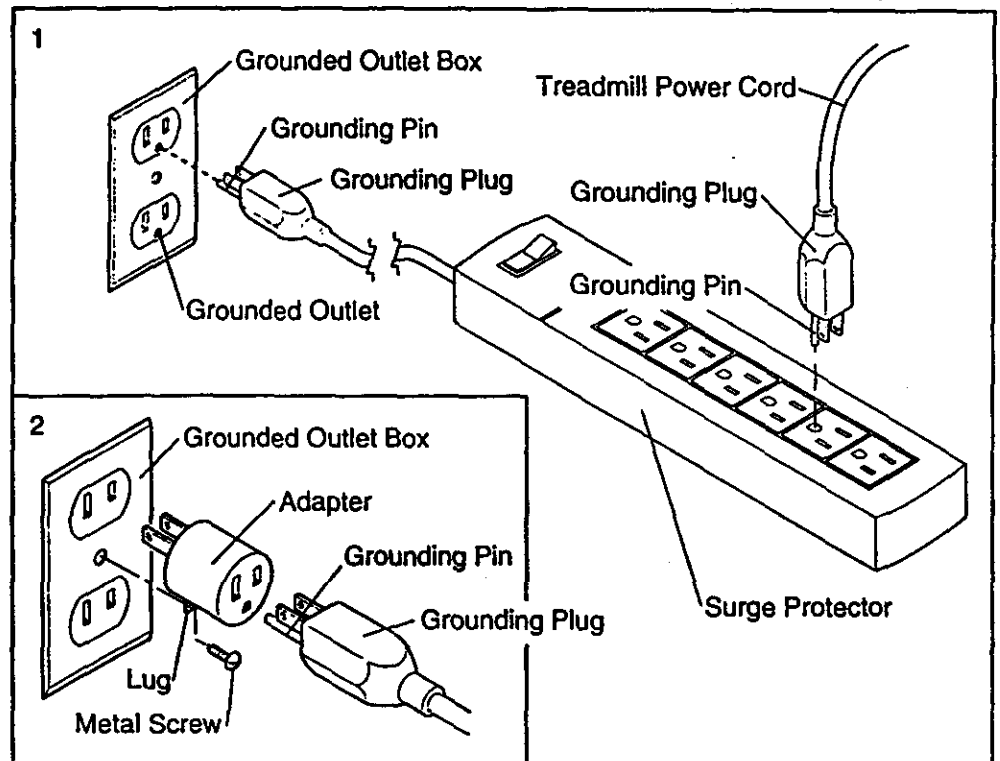
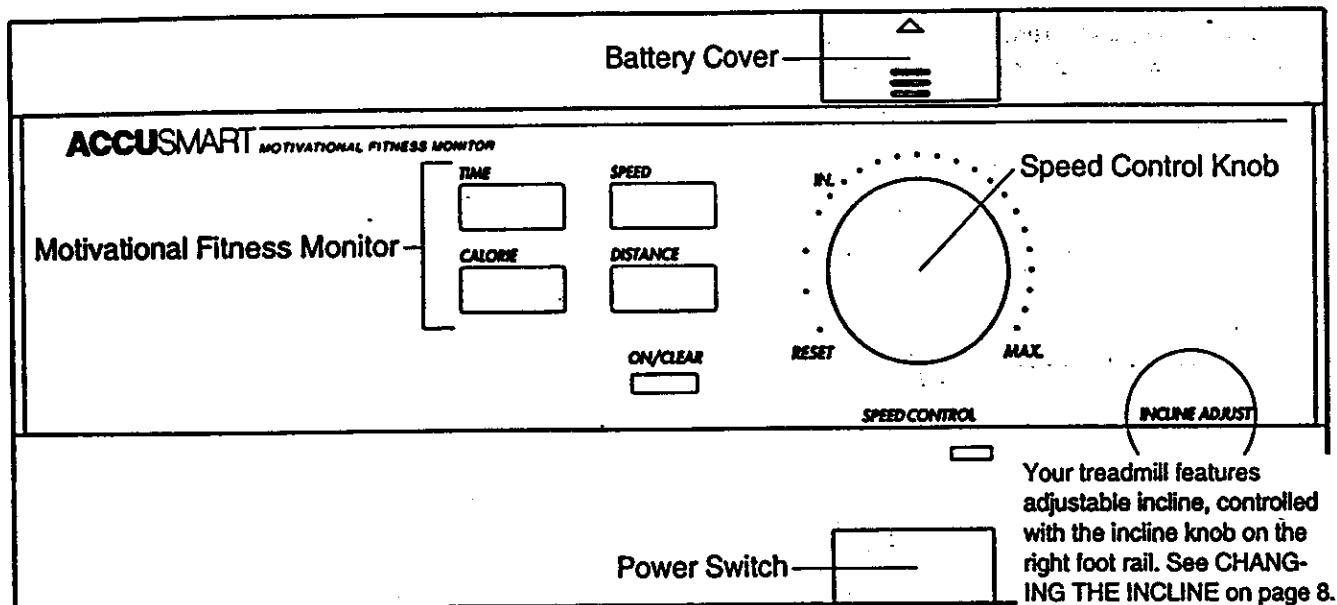

DIAGRAM OF THE CONSOLE



The CROSS WALK features the innovative ACCUSMART console, designed to help you get the most from your workouts. Please read the instructions below before operating the console. **Note:** If there is a thin sheet of clear plastic on the face of the console, remove it before operating the console.

CAUTION: Do not stand on the walking belt when turning on the power. Always wear the clip attached to the key while operating the CROSS WALK. After the speed control knob is turned, there will be a brief pause before the walking belt begins to move. Adjust the speed slowly until you are familiar with the CROSS WALK.

HOW TO TURN ON THE POWER

Make sure that the power cord is properly plugged in. (See HOW TO PLUG IN THE POWER CORD on page 6.)

Next, step onto the foot rails of the CROSS WALK and hold the upper body arms. (See HOW TO OPERATE THE UPPER BODY ARMS on page 8.) Locate the clip attached by a cord to the key. Slide the clip onto your waistband.

Insert the key into the power switch. The four displays of the motivational fitness monitor will not appear until the ON/CLEAR button is pressed or the walking belt begins to move. (See CONTROLLING THE SPEED OF THE WALKING BELT on this page.) **Note:** If batteries were just installed, the four displays will appear already.

CONTROLLING THE SPEED OF THE WALKING BELT

The walking belt will be motionless each time the power is turned on. To start the walking belt, first turn the speed control knob to the "RESET" position. Next, turn the knob slowly clockwise until the walking belt begins to move at slow speed.

Step carefully onto the walking belt and begin exercising. Change the speed of the walking belt as desired by turning the speed control knob. To stop the walking belt, turn the knob to the "RESET" position.

THE MOTIVATIONAL FITNESS MONITOR

The four displays of the motivational fitness monitor provide instant exercise feedback. The displays are described below. **Note:** The displays can be reset by pressing the ON/CLEAR button.

- **TIME**—This display shows the elapsed time. **Note:** When the walking belt is stopped, the TIME display will pause after a few seconds.
- **CALORIE**—This display shows the approximate number of nutritional Calories that you have burned.
- **SPEED**—This display shows the speed of the walking belt, in miles per hour.
- **DISTANCE**—This display shows the total distance that you have walked or run, in miles.

Note: If the walking belt is stopped for about five minutes, the four displays will be reset and will darken, although the power will remain on. The displays will appear again when the ON/CLEAR button is pressed, or the walking belt is restarted.

HOW TO TURN OFF THE POWER

To turn off the power, remove the key from the console. The power indicator will darken. Store the key in a secure location.

HOW TO OPERATE THE UPPER BODY ARMS

The upper body arms can be used in either the stationary position or the dual motion position.

To use the upper body arms in the stationary position, insert the lock pin through the arms and the upright (see the drawing below). Important: If it is difficult to insert the lock pin, do not hit the end of the lock pin; twist each upper body arm slightly in order to align the holes. Do not twist the upper body arms too far or the treadmill may be damaged.

Next, insert the hairpin cotter into the end of the lock pin. Firmly tighten the resistance control.

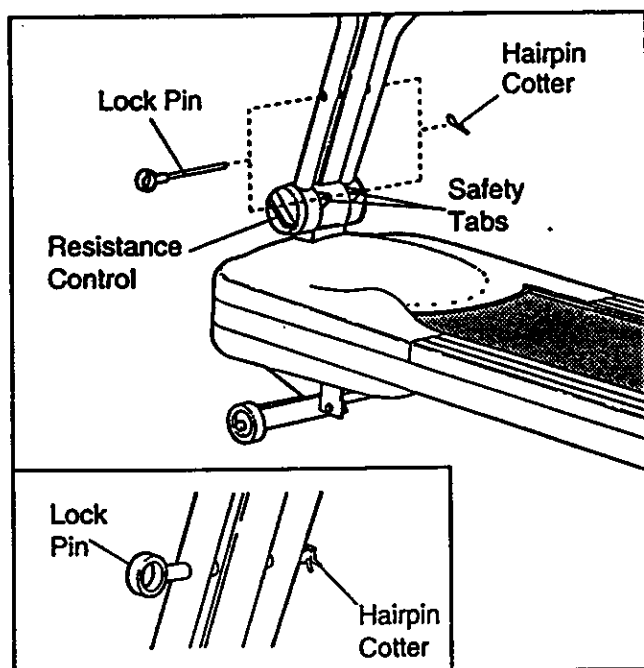

To use the upper body arms in the dual motion position, first make sure the resistance control is firmly tightened. Remove the lock pin from the upper body arms and the upright, and insert it through the safety

tabs at the base of the upright. Insert the hairpin cotter into the lock pin.

In the dual motion position, you can move the arms forward and back as you walk or run, exercising your arms, back and shoulders for a total body workout. To tailor the intensity of your exercise, the resistance of the arms can be changed. To increase the resistance, turn the resistance control clockwise; to decrease the resistance, turn the control counterclockwise.

CAUTION: Always insert the lock pin through the safety tabs when using the upper body arms in the dual motion position. If you fall while exercising, the lock pin will limit the downward movement of the arms. When the lock pin is inserted through the safety tabs, do not lean on the upper body arms or the lock pin may be damaged. If the hairpin cotter is not attached to the lock pin as instructed, the lock pin may slip out, resulting in injury to the user.

CHANGING THE INCLINE

To vary the intensity of your exercise, the incline of the treadmill can be changed. Before changing the incline, make sure that the walking belt is stopped.

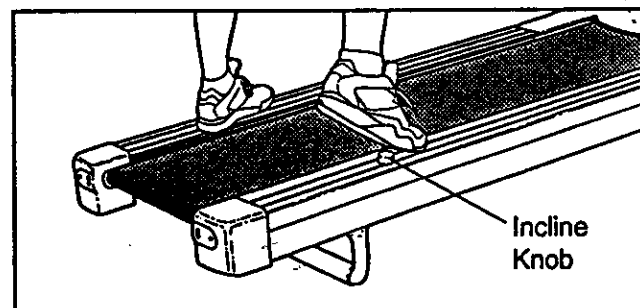

To increase the incline, stand with your left foot towards the back of the left foot rail as shown below. Using your right foot, press down the incline knob on the right foot rail, until the desired incline is reached. To decrease the incline, stand with your left foot towards the front of the left foot rail, and press down the incline knob until the desired incline is reached.

TROUBLE-SHOOTING AND MAINTENANCE

Most treadmill problems can be solved by following the simple steps below. Find the symptom that applies, and follow the steps listed. If further assistance is needed, call our toll-free HOTLINE at 1-800-736-6879, Monday through Saturday, 7 a.m. until 7 p.m. Central Time (excluding holidays).

1. SYMPTOM: THE POWER DOES NOT TURN ON

- Make sure that the power cord is plugged into a surge protector, and that the surge protector is plugged into a properly grounded outlet. (See HOW TO PLUG IN THE POWER CORD on page 6.) Use only a UL-listed surge protector, rated at 15 amps, with a 14-gauge cord of five feet or less in length.
- Make sure that the key is inserted fully into the console. Turn the speed control knob to the "reset" position. (See HOW TO TURN ON THE POWER on page 7.)
- Check the circuit breaker located on the front of the frame. The circuit breaker is designed to protect the electrical system. If the circuit breaker has tripped, the switch will protrude as shown. To reset the circuit breaker, allow the CROSS WALK to cool for five minutes, and then push the switch back in.

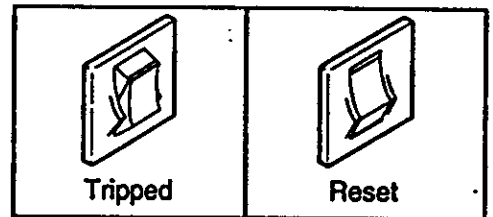

2. SYMPTOM: THE POWER TURNS OFF DURING USE

- Make sure that the power cord is plugged in.
- Check the circuit breaker located on the front of the frame. If the circuit breaker has tripped, the switch will protrude. (See the drawing above.) To reset the circuit breaker, allow the CROSS WALK to cool for five minutes, and then push the switch back in.
- Remove the key from the console. Reinsert the key fully into the console. Turn the speed control knob to the "reset" position.

3. SYMPTOM: THE MOTIVATIONAL FITNESS MONITOR DOES NOT FUNCTION PROPERLY

- Check the batteries in the console. (See HOW TO INSTALL BATTERIES IN THE CONSOLE on page 5.) Most problems are the result of drained batteries.

4. SYMPTOM: THE CROSS WALK DOES NOT INCLINE

- Stand with your left foot towards the back of the foot rail while increasing the incline. Stand with your left foot towards the front of the foot rail while decreasing the incline. You may need to raise and lower the treadmill several times to break in the incline shock. (See CHANGING THE INCLINE on page 8.)

5. SYMPTOM: THE WALKING BELT SLOWS WHEN WALKED ON

- Use only a UL-listed surge protector, rated at 15 amps, with a 14-gauge cord of five feet or less in length.
- If the walking belt is overtightened, performance may be reduced and the walking belt permanently damaged. **UNPLUG THE POWER CORD.** Using the included allen wrench, turn both rear roller adjustment bolts counterclockwise 1/4 of a turn. When the tension of the walking belt is correct, you should be able to lift each side of the walking belt 2 to 3 inches; the center of the walking belt should just touch the surface of the walking platform. Be sure to keep the walking belt centered. Run the treadmill for a few minutes. Repeat until the tension of the walking belt is correct.

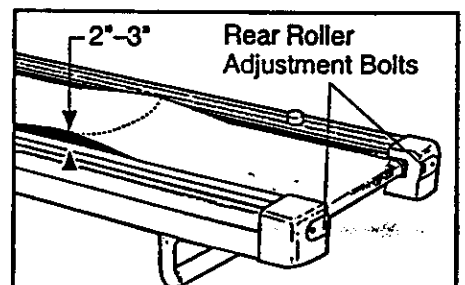

- If the walking belt still slows when walked on, please call our toll-free HOTLINE.

6. SYMPTOM: THE WALKING BELT IS OFF-CENTER OR SLIPS

a. If the walking belt has shifted to the left, first remove the key and **UNPLUG THE POWER CORD**. Using the allen wrench, turn the left rear roller adjustment bolt clockwise, and the right bolt counterclockwise, 1/4 of a turn each. Be careful not to overtighten the walking belt. Plug in the power cord, insert the key and run the treadmill for a few minutes. Repeat until the belt is centered.

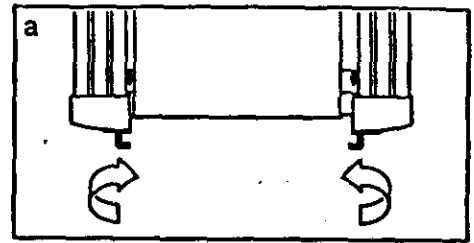

b. If the walking belt has shifted to the right, first remove the key and **UNPLUG THE POWER CORD**. Using the allen wrench, turn the left rear roller adjustment bolt counterclockwise, and the right bolt clockwise, 1/4 of a turn each. Be careful not to overtighten the walking belt. Plug in the power cord, insert the key and run the treadmill for a few minutes. Repeat until the belt is centered.

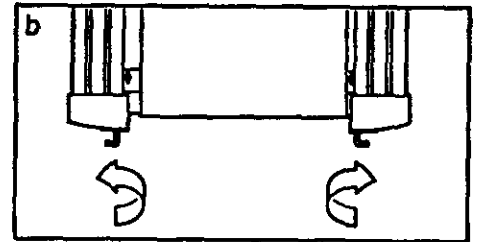

c. If the walking belt slips when walked on, first remove the key and **UNPLUG THE POWER CORD**. Using the allen wrench, turn both rear roller adjustment bolts clockwise, 1/4 of a turn. When the walking belt is correctly tightened, you should be able to lift each side of the walking belt 2-3 inches off the walking platform. The center of the walking belt should just touch the walking platform. Be careful to keep the walking belt centered. Plug in the power cord, insert the key and run the treadmill for a few minutes. Repeat until the walking belt is properly tightened.

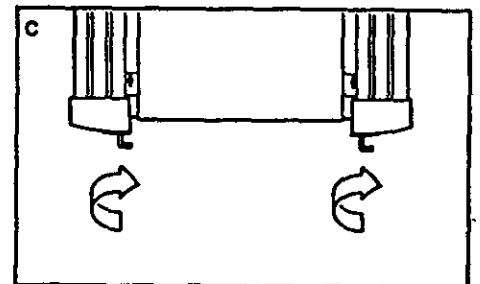

7. SYMPTOM: IT IS DIFFICULT TO INSERT OR REMOVE THE LOCK PIN

a. It may be necessary to twist each upper body arm slightly in order to align the holes that the lock pin goes through. Do not twist the upper body arms too far or you may damage the treadmill.

STORAGE

Before converting the **CROSS WALK** to the stowaway position, turn the Resistance Control (15) counterclockwise until the Control turns freely.

Unplug the power cord. Remove the Lock Knob (77) and Lock Knob Washer (78) from the Upright (10). Lay the Upright and the Left and Right Upper Body Arms (1, 2) on the walking belt. Keep the Lock Knob and Washer in a secure location.

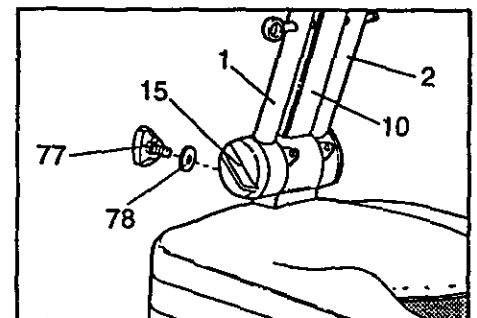

CONDITIONING GUIDELINES

The following guidelines will help you to plan your exercise program. Remember that proper nutrition and adequate rest are essential for successful results.

WARNING: Before beginning this or any exercise program, consult your physician. This is especially important for individuals over the age of 35 or individuals with pre-existing health problems.

EXERCISE INTENSITY

To maximize the benefits of exercising, it is important to exercise with the proper intensity. The proper intensity level can be found by using your heart rate as a guide. For effective aerobic exercise, your heart rate should be maintained at a level between 70% and 85% of your maximum heart rate as you exercise. This is known as your training zone. You can find your training zone in the table below. Training zones are listed for both unconditioned and conditioned persons according to age.

Age	Training Zone	
	Unconditioned (Beats/Min.)	Conditioned (Beats/Min.)
20	138-167	133-162
25	136-166	132-160
30	135-164	130-158
35	134-162	129-156
40	132-161	127-155
45	131-159	125-153
50	129-156	124-150
55	127-155	122-149
60	126-153	121-147
65	125-151	119-145
70	123-150	118-144
75	122-147	117-142
80	120-146	115-140
85	118-144	114-139

During the first few months of your exercise program, keep your heart rate near the low end of your training zone as you exercise. After a few months, your heart rate can be increased gradually until it is near the middle of your training zone as you exercise.

To measure your heart rate, stop exercising and place two fingers on your wrist as shown. Take a six-second heartbeat count, and multiply the result by 10 to find

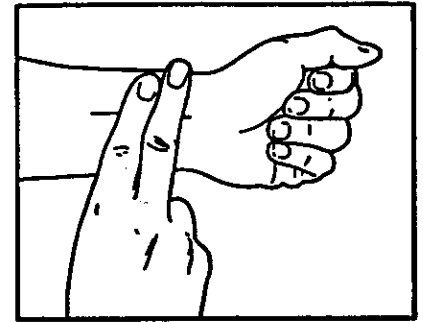

your heart rate. For example, if your six-second heartbeat count is 14, your heart rate is 140 beats per minute. (A six-second count is used because your heart rate will drop rapidly when you stop exercising.) Adjust the intensity of your exercise until your heart rate is at the proper level.

WORKOUT GUIDELINES

A well-rounded workout includes the following three phases:

A warm-up phase, lasting 5 to 10 minutes. Begin with slow, controlled stretches, and progress to more rhythmic stretches to increase the body temperature, heart rate and circulation in preparation for strenuous exercise. Stretching also guards against muscle, tendon and ligament sprains. (See SUGGESTED STRETCHES on page 13.)

A cardiovascular phase, including 20 to 30 minutes of exercising with your heart rate in your training zone.

A cool-down phase, consisting of 5 to 10 minutes of activity similar to that of the warm-up phase. Thorough stretching offsets muscle contractions and other problems caused when you stop exercising suddenly. Stretching for increased flexibility is often most effective during this phase. This phase should leave you relaxed and comfortably tired.

Instead of waiting for a convenient time to exercise, plan a specific time. The morning hours work well for many, and the self-discipline required to rise early and exercise often carries through the day to help increase productivity in other areas. For some, exercising before dinner initiates a period of winding down from the day's activities. Whatever time you choose, be consistent and stick with it.

To maintain or improve your condition, complete three workouts each week, with at least one day of rest between workouts. After a few months of regular exercise, you may complete up to five workouts each week, if desired. Remember, the key to success is **CONSISTENCY**.

WORKOUT ATTIRE

Exercise clothing should be comfortable and allow unrestricted movement. Do not wear rubberized or plastic clothing that can interfere with the evaporation of sweat from your skin. Always wear athletic shoes that are flexible and provide good protection and support.

ADDITIONAL SUGGESTIONS

Creating a more active lifestyle, in addition to establishing a regular exercise program, will help you to achieve your fitness goals. It's easy to improve your lifestyle by making a few changes in your daily routine:

- Keep yourself moving throughout the day. Use the stairs instead of the elevator. Park a half mile away from work or get off the bus a couple of blocks before your stop and walk the remaining distance.
- Increase midday productivity, creativity and energy by replacing a heavy lunch with a light meal. Spend the extra time in physical activity such as walking.

- Substitute manually-operated devices for automatic equipment such as lawn-care machinery, power tools and snow removers.
- Stop smoking; smoking nearly doubles the risk of coronary heart disease. (Framington Heart Study)
- Reduce or eliminate alcohol consumption. Alcohol is a major cause of liver problems and other health disorders. (Office of Disease Prevention and Health Promotion)
- Reduce your intake of fat. Less than 30% of the calories you consume each day should come from fat. Excessive fat consumption has been linked to numerous causes of death, including heart disease and cancer.
- Know and keep a record of your cholesterol level, blood pressure and other health information. Keep your blood pressure below 140/90; keeping it below 125/85 is preferable.

SUGGESTED STRETCHES

The following stretches can provide a good warm-up or cool-down. Correct form for each stretch is shown in the drawings below. Move slowly as you stretch—never bounce.

TOE TOUCH STRETCH

Stand with your knees bent slightly and slowly bend forward from your hips. Allow your back and shoulders to relax as you reach down toward your toes as far as possible. Hold for 15 counts, then relax. Repeat 3 times.

Stretches: Hamstrings, back of knees and back.

HAMSTRING STRETCH

Sit with one leg extended. Bring the sole of the opposite foot toward you and rest it against the inner thigh of your extended leg. Reach toward your toes as far as possible. Hold for 15 counts, then relax. Repeat 3 times for both legs.

Stretches: Hamstrings, lower back and groin.

CALF/ACHILLES STRETCH

With one leg in front of the other, reach forward and place your hands against a wall. Keep your back leg straight and your back foot flat on the floor. Bend your front leg, lean forward and move your hips toward the wall. Hold for 15 counts, then relax. Repeat 3 times for both legs. To cause further stretching of the achilles tendons, bend your back leg as well.

Stretches: Calves, achilles tendons and ankles.

QUADRICEPS STRETCH

With one hand against a wall for balance, reach back and grasp one foot with your other hand. Bring your heel as close to your buttocks as possible. Hold for 15 counts, then relax. Repeat 3 times for both legs.

Stretches: Quadriceps and hip muscles.

INNER THIGH STRETCH

Sit with the soles of your feet together and your knees outward. Pull your feet toward your groin area as far as possible. Hold for 15 counts, then relax. Repeat 3 times.

Stretches: Quadriceps and hip muscles.

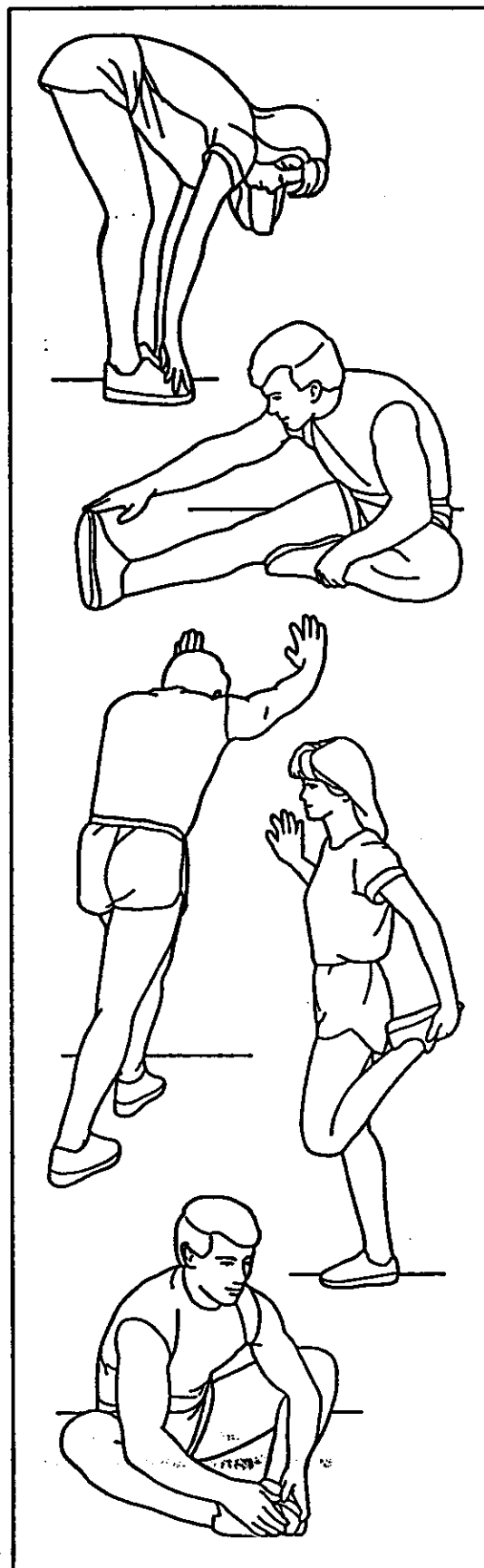

PART LIST—Model No. 831.297231

R0296A

Key No.	Part No.	Qty.	Description	Key No.	Part No.	Qty.	Description
1	125260	1	Left Upper Body Arm/Foam/Housing	54	125266	1	Walking Platform w/Fastener
2	125261	1	Right Upper Body Arm/Foam/Housing	55	100691	6	Platform Screw
3	015044	1	Hairpin Cotter	56	014127	3	Roller Adjustment Washer
4	012108	1	Motor Swivel Nut	57	112609	1	Front Roller Adjustment Bolt
5	114575	1	Key/Clip	58	126110	1	Front Roller/Pulley
6	108404	10	Screw	59	124098	1	Walking Belt w/Fastener
7*	127726	1	Console/Pot/Knob/Battery Cover	60	121267	1	Upright Cover, Long
8	110000	1	Speed Control Knob	61	110407	1	Rear Leg Pad
9	126242	1	Foot Incline Knob	62	125268	1	Right Endcap
10	121266	1	Upright	63	013300	3	Reed Switch Screw
11	121544	1	Lock Pin	64	105444	2	Rear Roller Adjustment Bolt
12	109786	1	Controller	65	016028	1	Wrench Clip
13	124009	2	Incline Leg Washer	66	045010	1	Allen Wrench
14	125263	1	Motor Hood w/Decal	67	110245	1	Rear Roller
15	116693	1	Resistance Control	68	014066	1	Cable Washer
16	110193	2	Friction Bracket	69	121268	1	Short Upright Cover
17	014087	2	Flat Washer	70	124318	2	Belt Guide
18	122634	2	Upper Body Arm Housing	71	125267	1	Left Endcap
19	112286	2	Friction Plate	72	100498	1	Magnet
20	124301	1	Incline Cable	73	115569	1	Reed Switch/Sensor Wire
21	126155	2	Shock Spacer	74	121272	1	Mechanism Cover
22	126243	1	Incline Knob Sleeve	75	118016	1	Belt
23	122812	1	Tension Washer	76	016055	2	Wire Clip
24	013547	1	Tension Bolt	77	017088	1	Lock Knob
25	113106	5	Hood Bracket	78	014156	2	Lock Knob Washer/Control Washer
26	109382	1	Circuit Breaker	79	121269	1	Friction Cover
27	124695	1	Grommet	80	109515	1	Pivot Bolt
28	014157	1	Reed Switch Washer	81	112023	2	Foam Grip
29	031238	1	Choke	82	101049	5	Hood Bracket Screw
30	124669	1	Power Cord	83	105477	2	Motor Nut
31	013162	8	Safety Cover Screw	84	111869	1	Cage Nut
32	125790	1	Safety Cover	85	016029	2	4" Cable Tie
33	125264	1	Left Foot Rail w/Fastener	86	120630	10	Belt Guide Screw/Bracket Screw
34	052014	2	Front Wheel	87	012146	2	Cable Nut
35	117806	2	Wheel Bolt	88	016057	3	8" Cable Tie
36	118202	1	Shock Release	89	012056	4	Nut
37	115672	1	Shock Bracket	90	116435	1	Incline Lever
38	054016	1	E-Clip	91	124302	1	Incline Knob Bracket
39	059019	1	Shock Cushion	92	014117	1	Motor Tension Star Washer
40	111436	1	Incline Shock	93	124615	1	Upright Wire Harness
41	106616	1	Shock Pin	94	113203	1	6" Cable Loom
42	106334	1	Cotter Pin	95	127727	1	Potentiometer
43	107503	1	Motor Pivot Bolt	96	124703	1	Pot Wire
44	122632	1	Motor Mount Bracket	97	110402	1	Battery Cover
45	120867	1	Motor Tension Nut	98*	124151	1	Motor/Pulley/Flywheel/Fan
46	124100	1	Motor	#	116131	1	Power Board Wire Harness
47	113814	2	Motor Bolt	#	107109	12	Fastener
48	112825	1	Pulley/Flywheel/Fan	#	124762	1	4" Black Wire, Male/Female
49	125265	1	Right Foot Rail w/Fastener	#	107771	1	8" White Wire, Male/Female
50	114261	1	Motor Ground Wire	#	125824	1	Owner's Manual
51	121446	2	Incline Leg Bolt				
52	121109	1	Incline Leg				
53	NSP	1	Frame				

* Includes all the parts shown in the box.

indicates a non-illustrated part.

Specifications are subject to change without notice. See the back cover for information about ordering replacement parts.

EXPLODED DRAWING—Model No. 831.297231

R0296A

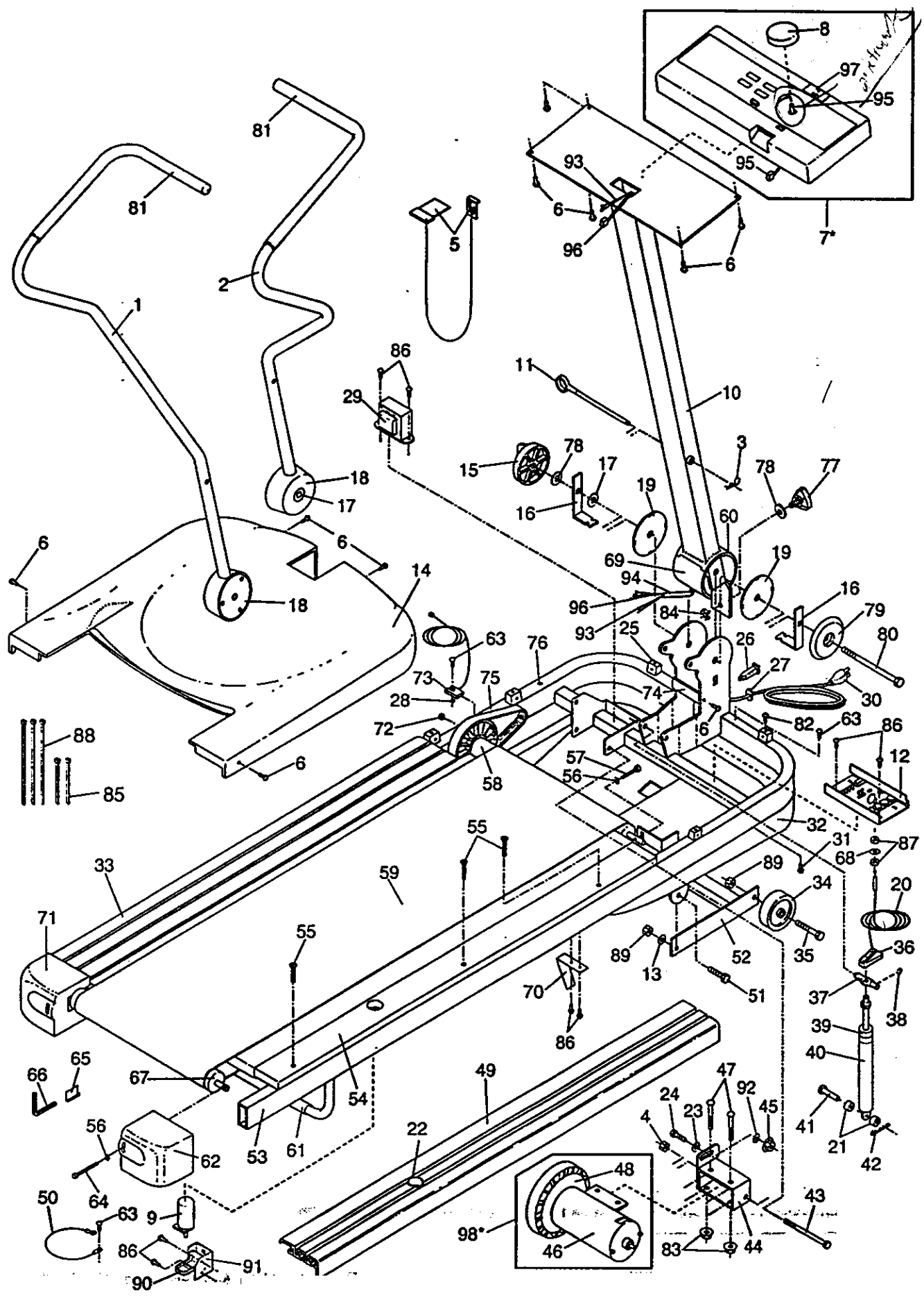

SEARS

Model No. 831.297231

QUESTIONS?

If you find that:

- you need help assembling or operating the CROSS WALK
- a part is missing
- or you need to schedule repair service

call our toll-free HELPLINE

1-800-736-6879

Monday-Saturday, 7 am-7 pm
Central Time (excluding holidays)

REPLACEMENT PARTS

If parts become worn and need to be replaced, call the following toll-free number

1-800-FON-PART
(1-800-366-7278)

The model number and serial number of your PROFORM® CROSS WALK Dual Motion Cross Trainer are listed on a decal attached to the frame. See the front cover of this manual to find the location of the decal.

All replacement parts are available for immediate purchase or special order when you visit your nearest SEARS Service Center. To request service or to order parts by telephone, call the toll-free numbers listed at the left.

When requesting help or service, or ordering parts, please be prepared to provide the following information:

- The NAME OF THE PRODUCT (PROFORM® CROSS WALK Dual Motion Cross Trainer)
- The MODEL NUMBER OF THE PRODUCT (831.297231)
- The PART NUMBER OF THE PART (see page 14 of this manual)
- The DESCRIPTION OF THE PART (see page 14 of this manual).

SEARS, ROEBUCK AND CO., HOFFMAN ESTATES, IL 60179 USA

