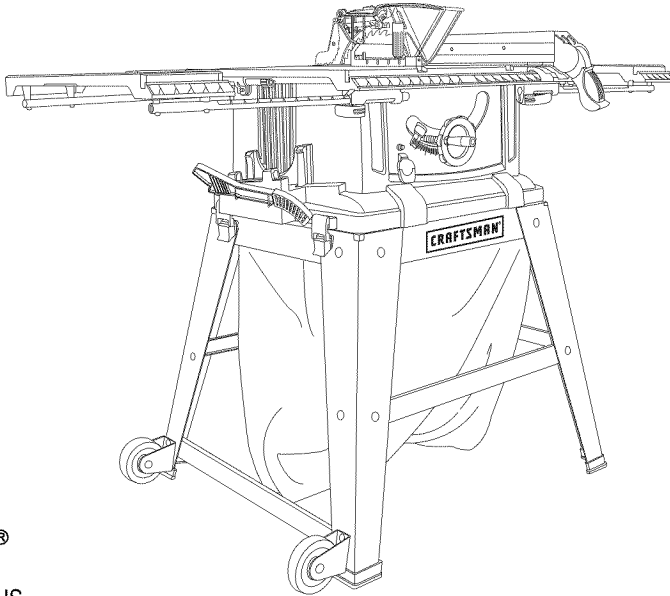


# Operator's Manual

# CRAFTSMAN®

## 10-in. TABLE SAW WITH LEG SET Model No. 137.218070



C US

### CAUTION:

Before using this Table Saw, read this manual and follow all its Safety Rules and Operating Instructions

- Safety Instructions
- Installation
- Operation
- Maintenance
- Parts List

**Customer Help Line  
For Technical Support  
1-800-843-1682**

**Sears Parts &  
Repair Center  
1-800-488-1222**

Sears, Roebuck and Co., Hoffman Estates, IL 60179 USA

Visit our Craftsman website: [www.sears.com/craftsman](http://www.sears.com/craftsman)

Part No. 137218070001

Printed in Taiwan

# TABLE OF CONTENTS

SECTION	PAGE
Warranty .....	2
Product Specifications .....	3
Symbols.....	4
Power Tool Safety .....	5
Table Saw Safety .....	8
Electrical Requirements and Safety .....	10
Accessories and Attachments .....	12
Tools Needed for Assembly .....	12
Carton Contents .....	13
Know Your Table Saw .....	15
Glossary of Terms .....	16
Assembly.....	18
Adjustments .....	28
Operation .....	34
Maintenance .....	43
Troubleshooting Guide .....	45
Parts List .....	48

## WARRANTY

### CRAFTSMAN ONE YEAR FULL WARRANTY

If this Craftsman tool fails due to a defect in material or workmanship within one year from the date of purchase, call 1-800-4-MY-HOME® to arrange for free repair (or replacement if repair proves impossible).

This warranty applies for only 90 days from the date of purchase if this product is ever used for commercial or rental purposes.

This warranty does not include expendable parts, such as lamps, batteries, bits or blades.

This warranty gives you specific legal rights, and you may also have other rights which vary from state to state.

**Sears, Roebuck and Co., Hoffman Estates, IL 60179**

### WARNING

Some dust created by using power tools contains chemicals known to the state of California to cause cancer and birth defects or other reproductive harm.

Some examples of these chemicals are:

- Lead from lead-based paints
- Crystalline silica from bricks, cement and other masonry products
- Arsenic and chromium from chemically treated lumber

Your risk from these exposures varies, depending on how often you do this type of work. To reduce your exposure to these chemicals, work in a well ventilated area and work with approved safety equipment such as dust masks that are specially designed to filter out microscopic particles.

# PRODUCT SPECIFICATIONS

## MOTOR

Type.....	Universal
Amperes.....	15 Amp
Voltage.....	120V AC
Hz.....	60Hz
RPM (no load) .....	5000 RPM (No load)
Overload Protection.....	Yes

## BLADE SIZE

Diameter.....	10 in.
Arbor size.....	5/8 in.

## SAW

Rip fence.....	Yes
Miter gauge.....	Yes
Rip Capacity .....	24 in. Right & Left
Maximum Cut Depth @ 90° .....	3 in.
Maximum Cut Depth @ 45° .....	2-1/2 in.
Maximum Diameter Dado .....	6 in. (Stackable only)
Maximum Dado Cut Width .....	1/2 in.

## WARNING

To avoid electrical hazards, fire hazards or damage to the tool, use proper circuit protection.

This tool is wired at the factory for 110-120 Volt operation. It must be connected to a 110-120 Volt / 15 Ampere time delay fuse or circuit breaker. To avoid shock or fire, replace power cord immediately if it is worn, cut or damaged in any way.

Before using your tool, it is critical that you read and understand these safety rules. Failure to follow these rules could result in serious injury to you or damage to the tool.

# SYMBOLS

## WARNING ICONS

Your power tool and its Operator's Manual may contain "WARNING ICONS" (a picture symbol intended to alert you to, and/or instruct you how to avoid, a potentially hazardous condition). Understanding and heeding these symbols will help you operate your tool better and safer. Shown below are some of the symbols you may see.



**SAFETY ALERT:** Precautions that involve your safety.



**PROHIBITION**



**WEAR EYE PROTECTION:** Always wear safety goggles or safety glasses with side shields.



**READ AND UNDERSTAND OPERATOR'S MANUAL:** To reduce the risk of injury, user and all bystanders must read and understand operator's manual before using this product.



**KEEP HANDS AWAY FROM BLADE:** Failure to keep your hands away from the blade will result in serious personal injury.



**SUPPORT AND CLAMP WORK**



**DANGER:** indicates an imminently hazardous situation which, if not avoided, will result in death or serious injury.



**WARNING:** indicates a potentially hazardous situation which, if not avoided, could result in death or serious injury.



**CAUTION:** indicates a potentially hazardous situation which, if not avoided, may result in minor or moderate injury.



**CAUTION:** used without the safety alert symbol indicates a potentially hazardous situation which, if not avoided, may result in property damage.


# POWER TOOL SAFETY

## GENERAL SAFETY INSTRUCTIONS BEFORE USING THIS POWER TOOL

Safety is a combination of common sense, staying alert and knowing how to use your power tool.

### **WARNING**

To avoid mistakes that could cause serious injury, do not plug the tool in until you have read and understood the following.

-  **1. READ** and become familiar with the entire Operator's Manual. **LEARN** the tool's application, limitations and possible hazards.
- 2. KEEP GUARDS IN PLACE** and in working order.
- 3. REMOVE ADJUSTING KEYS AND WRENCHES.** Form the habit of checking to see that keys and adjusting wrenches are removed from the tool before turning ON.
- 4. KEEP WORK AREA CLEAN.** Cluttered areas and benches invite accidents.
- 5. DO NOT USE IN DANGEROUS ENVIRONMENTS.** Do not use power tools in damp locations, or expose them to rain or snow. Keep work area well lit.

- 6. KEEP CHILDREN AWAY.** All visitors and bystanders should be kept a safe distance from work area.
- 7. MAKE WORKSHOP CHILD PROOF** with padlocks, master switches or by removing starter keys.
- 8. DO NOT FORCE THE TOOL.** It will do the job better and safer at the rate for which it was designed.
- 9. USE THE RIGHT TOOL.** Do not force the tool or an attachment to do a job for which it was not designed.
- 10. USE PROPER EXTENSION CORDS.** Make sure your extension cord is in good condition. When using an extension cord, be sure to use one heavy enough to carry the current your product will draw. An undersized cord will result in a drop in line voltage and in loss of power which will cause the tool to overheat. The table on page 11 shows the correct size to use depending on cord length and nameplate ampere rating. If in doubt, use the next heavier gauge. The smaller the gauge number, the heavier the cord.
- 11. WEAR PROPER APPAREL.** Do not wear loose clothing, gloves, neckties, rings, bracelets or other jewelry which may get caught in moving parts. Non-slip footwear is recommended. Wear protective hair covering to contain long hair.

## 12. ALWAYS WEAR EYE



**PROTECTION.** Any power tool can throw foreign objects into the eyes and could cause permanent eye damage. **ALWAYS** wear Safety Goggles (not glasses) that comply with ANSI Safety standard Z87.1. Everyday eyeglasses have only impact-resistant lenses. They **ARE NOT** safety glasses. Safety Goggles are available at Sears.  
**NOTE:** Glasses or goggles not in compliance with ANSI Z87.1 could seriously injure you when they break.

13. **WEAR A FACE MASK OR DUST MASK.** Sawing operation produces dust.

14. **SECURE WORK.** Use clamps or a vise to hold work when practical. It is safer than using your hand and it frees both hands to operate the tool.



15. **DISCONNECT TOOLS FROM POWER SOURCE** before servicing, and when changing accessories such as blades, bits and cutters.

16. **REDUCE THE RISK OF UNINTENTIONAL STARTING.** Make sure switch is in the OFF position before plugging the tool in.

## 17. USE RECOMMENDED

**ACCESSORIES.** Consult this Operator's Manual for recommended accessories. The use of improper accessories may cause risk of injury to yourself or others.

18. **NEVER STAND ON THE TOOL.** Serious injury could occur if the tool is tipped or if the cutting tool is unintentionally contacted.

19. **CHECK FOR DAMAGED PARTS.** Before further use of the tool, a guard or other part that is damaged should be carefully checked to determine that it will operate properly and perform its intended function – check for alignment of moving parts, binding of moving parts, breakage of parts, mounting and any other conditions that may affect its operation. A guard or other part that is damaged should be properly repaired or replaced.

20. **NEVER LEAVE THE TOOL RUNNING UNATTENDED. TURN THE POWER "OFF".** Do not walk away from a running tool until the blade comes to a complete stop and the tool is unplugged from the power source.

21. **DO NOT OVERREACH.** Keep proper footing and balance at all times.

**22. MAINTAIN TOOLS WITH CARE.**

Keep tools sharp and clean for best and safest performance. Follow instructions for lubricating and changing accessories.

23. **WARNING:** Dust generated from certain materials can be hazardous to your health. Always operate saw in well-ventilated area and provide for proper dust removal.

24.




People with electronic devices, such as pacemakers, should consult their physician(s) before using this product. Operation of electrical equipment in close proximity to a heart pacemaker could cause interference or failure of the pacemaker.

# TABLE SAW SAFETY

- 1. ALWAYS USE SAW BLADE GUARD**, riving knife and anti-kickback pawls for every through-sawing operation. Through-sawing operations are those in which the blade cuts completely through the workpiece when ripping or crosscutting. Always be sure blade guard is tightened securely.
- 2. ALWAYS HOLD WORK FIRMLY** against the miter gauge or rip fence.
- 3. ALWAYS USE** a push stick or push block, especially when ripping narrow stock. Refer to ripping instructions in this Operator's Manual where the push stick is covered in detail. A pattern for making your own push stick is included on page 47.
- 4. NEVER PERFORM ANY OPERATION FREEHAND**, which means using only your hands to support or guide the workpiece. Always use either the fence or the miter gauge to position and guide the work.
- 5. NEVER STAND** or have any part of your body in line with the path of the saw blade. Keep your hands out of the saw blade path.
- 6. NEVER REACH** behind or over the cutting tool for any reason.
- 7. REMOVE** the rip fence when crosscutting.
- 8. DO NOT USE** a molding head with this saw.
- 9. FEED WORK INTO THE BLADE** against the direction of rotation only.
- 10. NEVER** use the rip fence as a cut-off gauge when crosscutting.
- 11. NEVER ATTEMPT TO FREE A STALLED SAW BLADE** without first turning the saw OFF. Turn power switch OFF immediately to prevent motor damage.
- 12. PROVIDE ADEQUATE SUPPORT** to the rear and the sides of the saw table for long or wide workpieces.
- 13. AVOID KICKBACKS** (work thrown back towards you) by keeping the blade sharp, the rip fence parallel to the saw blade and by keeping the riving knife, anti-kickback pawls and guards in place, aligned and functioning. Do not release work before passing it completely beyond the saw blade. Do not rip work that is twisted, warped or does not have a straight edge to guide it along the fence. Do not attempt to reverse out of a cut with the blade running.
- 14. AVOID AWKWARD OPERATIONS** and hand positions where a sudden

## DANGER

**FREEHAND CUTTING IS THE MAJOR CAUSE OF KICKBACK AND FINGER/HAND AMPUTATIONS. NEVER USE THE MITER GAUGE AND FENCE SIMULTANEOUSLY.**

- slip could cause your hand to move into the saw blade.
15. **NEVER USE SOLVENTS** to clean plastic parts. Solvents could possibly dissolve or otherwise damage the material. Only a soft damp cloth should be used to clean plastic parts.
  16. **MOUNT** your table saw on a bench or stand before performing any cutting operations. Refer to **ASSEMBLY** on page 20.
  17.  **WARNING**  
Never cut metals or masonry products with this tool. This table saw is designed for use on wood and wood-like products.
  18. **ALWAYS USE IN A WELL-VENTILATED AREA.** Remove sawdust frequently. Clean out sawdust from the interior of the saw to prevent a potential fire hazard.
  19. **NEVER LEAVE THE SAW RUNNING UNATTENDED.** Do not leave the saw until the blade comes to a complete stop.
  20. For proper operation follow the instructions in this Operator's Manual entitled **OPERATION** (Page 34).  
**NOTE:** On machines with no stand or if stand is not being used, a hole approximately 11 in. square must be cut under saw to allow sawdust to fall through. Failure to cut this hole will allow sawdust to build up in the motor area, resulting in a fire hazard and potential motor damage.
  21. **USE ONLY** saw blades recommended with warning that the riving knife shall not be thicker than the width of the groove cut by the saw blade and not thinner than the body of the saw blade.
  22. **USE PUSH-STICK OR PUSH BLOCK** to feed the workpiece past the saw blade. The push-stick or push block should always be stored with the machine when not in use.
  23. Use and correct adjustment of the riving knife.

# ELECTRICAL REQUIREMENTS AND SAFETY

## GROUNDING INSTRUCTIONS

**IN THE EVENT OF A MALFUNCTION OR BREAKDOWN**, grounding provides a path of least resistance for electric currents and reduces the risk of electric shock. This tool is equipped with an electrical cord that has an equipment-grounding conductor and a grounding plug. The plug must be plugged into a matching receptacle that is properly installed and grounded in accordance with all local codes and ordinances.

**DO NOT MODIFY THE PLUG PROVIDED.** If it will not fit the receptacle, have the proper receptacle installed by a qualified electrician.

**IMPROPER CONNECTION** of the equipment grounding conductor can result in risk of electric shock. The conductor with the green insulation (with or without yellow stripes) is the equipment grounding conductor. If repair or replacement of the electrical cord or plug is necessary, do not connect the equipment grounding conductor to a live terminal.

**CHECK** with a qualified electrician or service person if you do not completely understand the grounding instructions, or if you are not certain the tool is properly grounded.

**USE** only three-wire extension cords that have three-pronged grounding plugs with three-pole receptacles that accept the tool's plug. Repair or replace damaged or worn cords immediately.

## GUIDELINES FOR EXTENSION CORDS

**USE THE PROPER EXTENSION CORD.** Make sure your extension cord is in good condition. Use an extension cord heavy enough to carry the current your product will draw. An undersized cord will cause a drop in line voltage resulting in loss of power, overheating and burning out of the motor. The table on the right shows the correct size to use depending on cord length and nameplate ampere rating. If in doubt, use the next heavier gauge. The smaller the gauge number, the heavier the cord.

Make sure your extension cord is properly wired and in good condition. Always replace a damaged extension cord or have it repaired by a qualified technician before using it. Protect your extension cords from sharp objects, excessive heat and damp or wet areas.

Use a separate electrical circuit for your tool. This circuit must not be less than #12 wire with a 20 A time-lag fuse or a #14 wire with a 15 A time-lag fuse. **NOTE:** When using an extension cord on a circuit with a #14 wire, the extension cord must not exceed 25 feet in length. Before connecting the motor to the power line, make sure the switch is in the off position and the electric current is rated the same as the current stamped on the motor nameplate. Running at a lower voltage will damage the motor. This tool is intended for use on a circuit that has a receptacle like the one illustrated in Fig. 1.

Fig. 1 shows a three-pronged electrical plug and receptacle that has a grounding conductor. If a properly grounded receptacle is not available, an adapter (Fig. 2) can be used to temporarily connect this plug to a two-contact grounded receptacle. The adapter (Fig. 2) has a rigid lug extending from it that **MUST** be connected to a permanent earth ground, such as a properly grounded receptacle box.

**CAUTION**

**This tool must be grounded while in use to protect the operator from electric shock.**

<b>MINIMUM GAUGE FOR EXTENSION CORDS (AWG)</b>					
(When using 120 volts only)					
<b>Ampere Rating</b>		<b>Total length of Cord</b>			
More Than	Not More Than	25ft.	50ft.	100ft.	150ft.
0	6	18	16	16	14
6	10	18	16	14	12
10	12	16	16	14	12
12	16	14	12	Not Recommended	

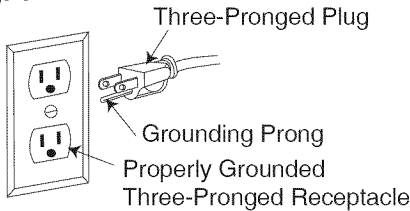
**CAUTION**

**In all cases, make certain the receptacle is properly grounded. If you are not sure, have a qualified electrician check the receptacle.**

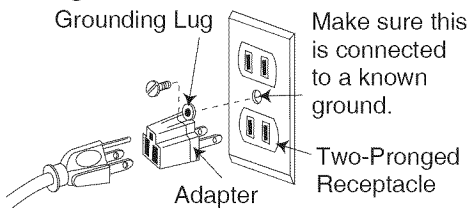
**CAUTION**

**This tool is for indoor use only. Do not expose to rain or use in damp locations.**

**Fig. 1**



**Fig. 2**



## ACCESSORIES AND ATTACHMENTS

### RECOMMENDED ACCESSORIES

#### WARNING

Visit your Sears Hardware Department or see the Craftsman Power and Hand Tools Catalog to purchase recommended accessories for this power tool.

#### WARNING

To avoid the risk of personal injury:

- Do not use adjustable (wobble) type dadoes or carbide tipped dado blades.
- Only use stackable dadoes.
- Maximum dado width is 1/2 in.
- Do not use a dado with a diameter larger than 6 in.
- Do not use molding head set with this saw.
- Do not modify this power tool or use accessories not recommended by Sears.

## TOOLS NEEDED FOR ASSEMBLY

### SUPPLIED



Blade wrench



Blade wrench



4 mm Hex wrench

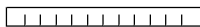
### NOT SUPPLIED



Flat bladed screwdriver



#2 Phillips screwdriver



Straight edge



Adjustable wrench and/or 8 mm, 13 mm, 14 mm wrench



Combination square

# CARTON CONTENTS

Separate all parts from packing materials. Check each part with the illustration on the next page and the “Table of Loose Parts” to make certain all items are accounted for, before discarding any packing material.

## **WARNING**

**If any part is missing or damaged, do not attempt to assemble the table saw, plug in the power**

**cord, or turn the switch ON until the missing or damaged part is obtained and is installed correctly. Call 1-800-843-1682 for missing or damaged parts.**

**NOTE:** To make assembly easier, keep contents of box together. Apply a coat of automobile wax to the table. Wipe all parts thoroughly with a clean dry cloth. This will reduce friction when pushing the workpiece.

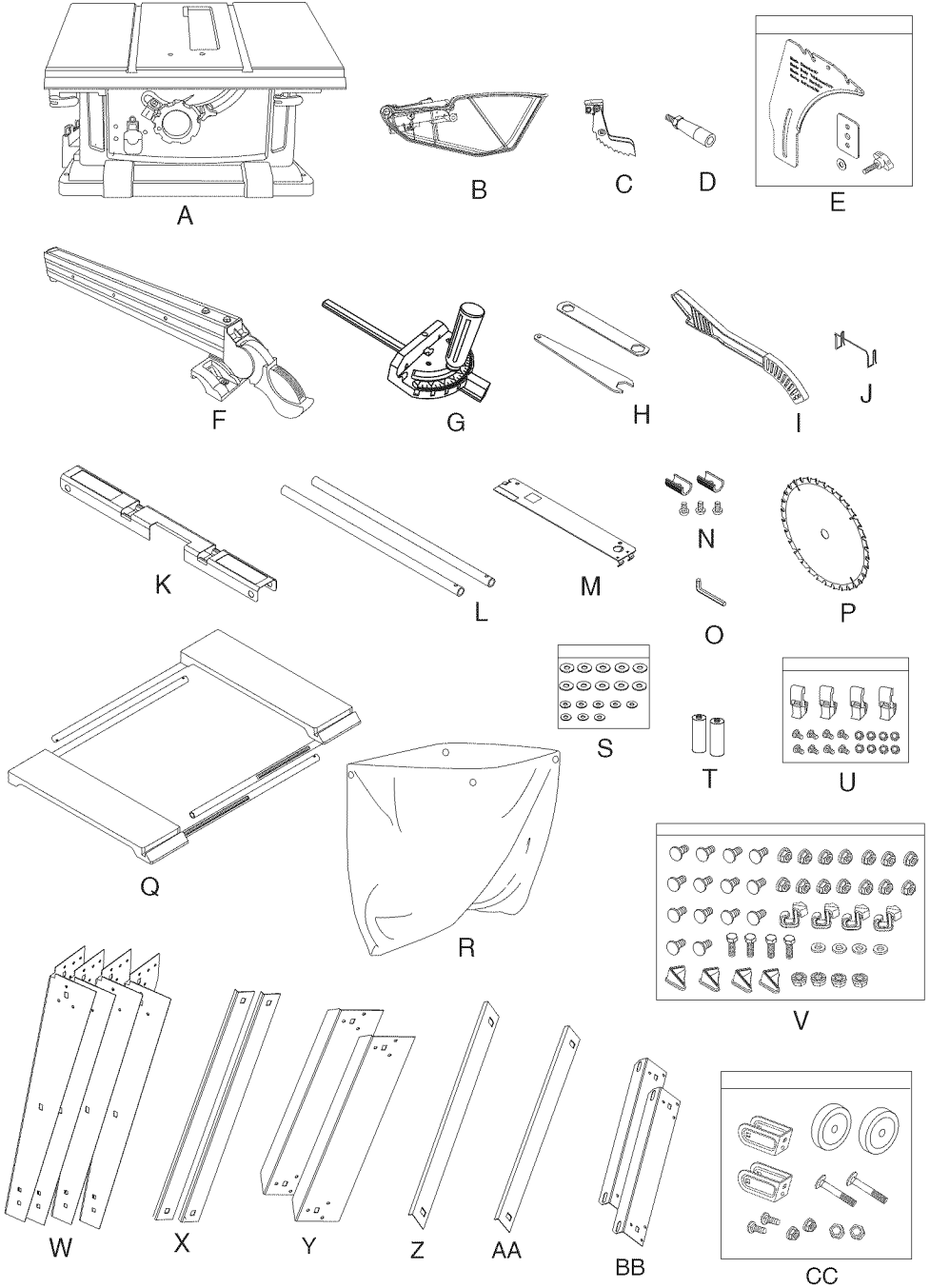
## TABLE OF LOOSE PARTS

ITEM	DESCRIPTION	QUANTITY
A	Table saw assembly	1
B	Blade guard assembly	1
C	Anti-kickback pawls assembly	1
D	Handwheel handle	1
E	Riving knife hardware bag assembly	1
F	Rip fence	1
G	Miter gauge	1
H	Blade wrench	2
I	Push stick	1
J	Push stick storage holder	1
K	Rear table extension	1
L	Rear table extension tube	2
M	Table insert	1
N	Table extension wing hardware bag assembly	1
O	Hex wrench	1
P	Blade	1
Q	Left and right extension table	1 each
R	Dust bag	1
S	Extension table hardware bag assembly	1
T	AAA Battery	2

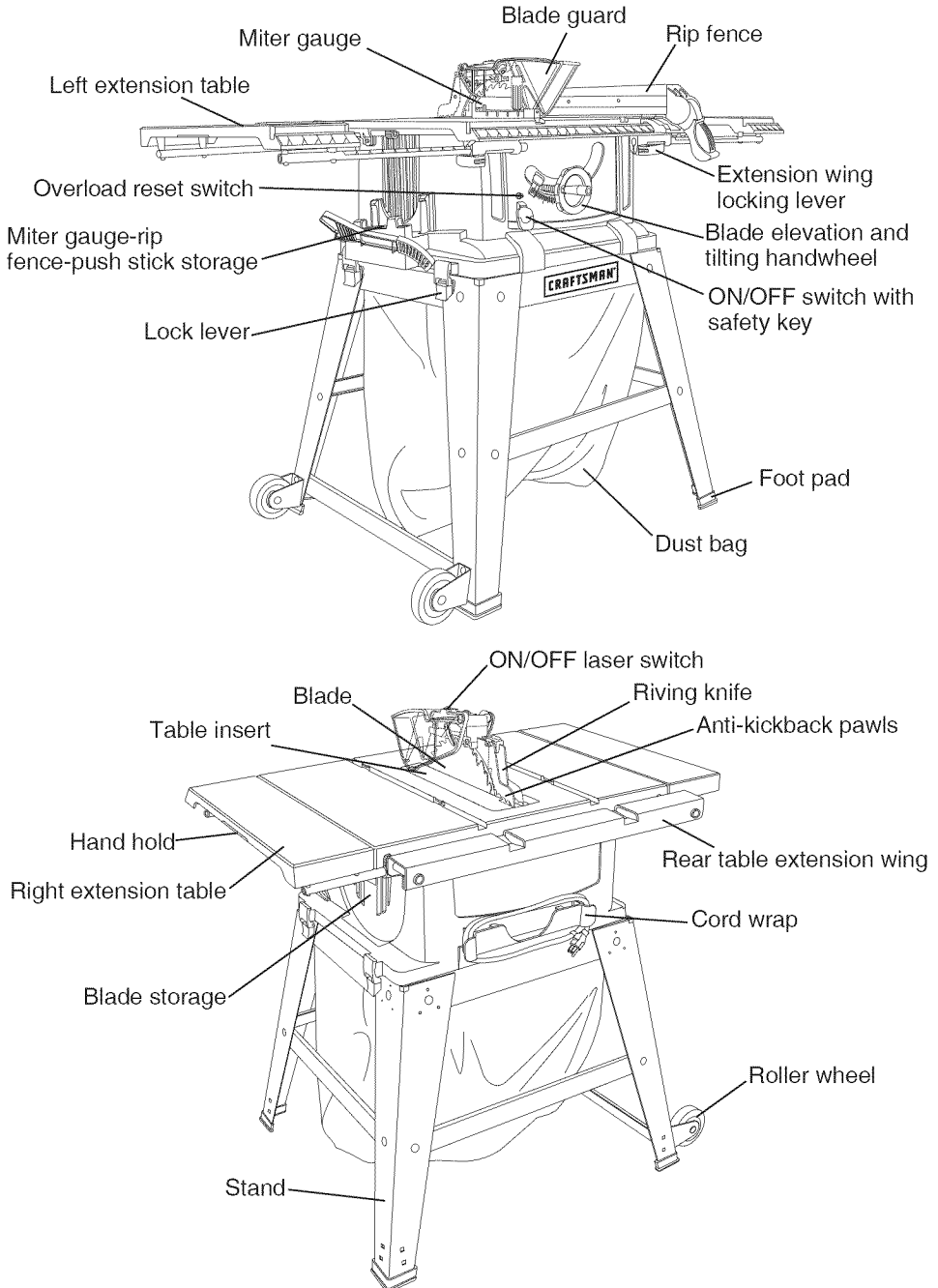
## STAND

U	Locking lever hardware bag assembly	1
V	Stand hardware bag assembly	1
W	Leg bracket	4
X	Bottom long support bracket	2
Y	Top long support bracket	2
Z	Bottom support bracket for roller wheel	1
AA	Bottom short support bracket	1
BB	Top short support bracket	2
CC	Roller wheel hardware bag assembly	1

# UNPACKING YOUR TABLE SAW



# KNOW YOUR TABLE SAW



# GLOSSARY OF TERMS

**ANTI-KICKBACK PAWLS** – Prevents the workpiece from being kicked upward or back toward the front of the table saw by the spinning blade.

**ARBOR** – The shaft on which the blade or dado is mounted.

**BEVEL CUT** – An angle cut made through the face of the workpiece.

**BLADE BEVEL SCALE** – Measures the angle the blade is tilted when set for a bevel cut.

**BLADE ELEVATION AND TILTING HANDWHEEL** – Raises and lowers the blade or tilts the blade to angle between 0° and 45° for bevel cuts.

**BLADE GUARD** – Clear plastic cover that positions itself over the blade while cutting.

**COMPOUND CUT** – A simultaneous bevel and miter cut.

**CROSSCUT** – A cut made across the width of the workpiece.

**DADO** – Special cutting blades that are used to cut grooves in a workpiece.

**FREEHAND** – Performing a cut without using a rip fence, miter gauge, hold down or other proper device to prevent

the workpiece from twisting during the cutting operation.

**GUM** – A sticky sap from wood products.

**HEEL** – Misalignment of the blade.

**JAMB NUT** – Nut used to lock another nut in place on a threaded rod or bolt.

**KERF** – The amount of material removed by the blade cut.

**MITER CUT** – An angle cut made across the width of the workpiece.

**MITER GAUGE** – A guide used for crosscutting operations that slides in the table top channels (grooves) located on either side of the blade. It helps make accurate straight or angle crosscuts.

**OVERLOAD RESET SWITCH** – Protects the motor if it overloads during operation, provides a way to restart the saw.

**PUSH STICK** – Used to push workpieces when performing ripping operations.

**PUSH BLOCK** – Used for ripping operation when the workpiece is too narrow to use a push stick. Always use a push block for rip widths less than 2 in.

**FEATHERBOARD** – When ripping a workpiece on your table saw, this keeps it firmly and safely against the rip fence. It also helps prevent chatter, gouging, and dangerous kickback.

**REVOLUTIONS PER MINUTE (RPM)**  
– The number of turns completed by a spinning object in one minute.

**RIP FENCE** – A guide used for rip cutting which allows the workpiece to cut straight.

**RIPPING** – Cutting with the grain of the wood or along the length of the workpiece.

**RIVING KNIFE** – A metal piece of the guard assembly located behind and moves with the blade. Slightly thinner than the saw blade, it helps keep the kerf open and prevents kickback.

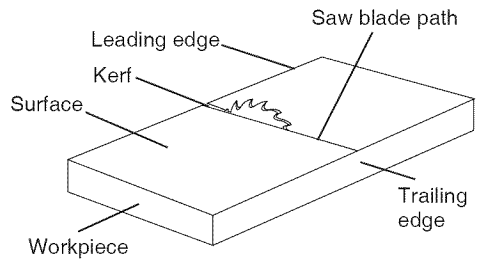
**SAW BLADE PATH** – The area of the workpiece or table top directly in line with the travel of the blade or the part of the workpiece that will be cut.

**SET** – The distance between two saw blade tips, bent outward in opposite directions to each other. The further apart the tips are, the greater the set.

**TABLE INSERT** – Insert that is removed from the table to install / remove blades. It is also removed for dado cutting. When dado cutting, a dado insert plate must be used.

**THROUGH SAWING** – Making a cut completely through the length or width of a workpiece.

**WORKPIECE** – Material to be cut.



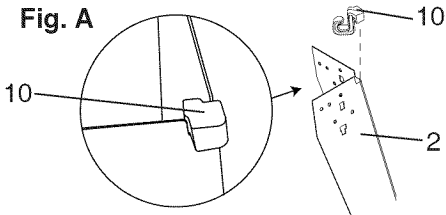
# ASSEMBLY

## ASSEMBLE STAND (FIG. A, B, C)

1. Unpack all parts and group by type and size. Refer to the parts list for correct quantities.
2. Attach four hooks (10) to the top corner of the four legs (2) as shown. The hooks (10) are used to hold the dust bag.

**NOTE:** Make sure the hook (10) is securely fastened to the corner of the leg (2).

Fig. A

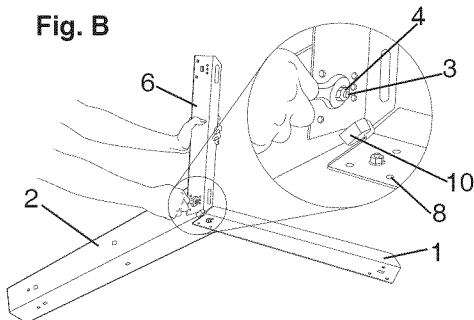


3. Attach one long upper support with label (1) to top of leg (2) using one bolt (3) and nut (4).

**NOTE:**

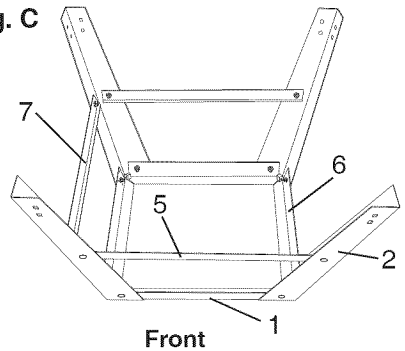
- Align detents (8) in stand leg with support brackets to ensure proper fit.
  - Do not tighten bolts until stand is properly aligned.
  - Position all supports to the **INSIDE** of the leg assemblies.
4. Attach short upper supports (6) to other hole of leg (2) using one bolt and nut.

Fig. B



5. Assemble the other upper supports in exactly the same manner.
6. Attach one bottom support (5) to the center of the leg using bolt (3) and nut (4). This completes the front frame section.
7. Assemble rear frame section in exactly the same manner.
8. Join front-bottom and rear-bottom frame assemblies using the bottom support (7), bolts and nuts.

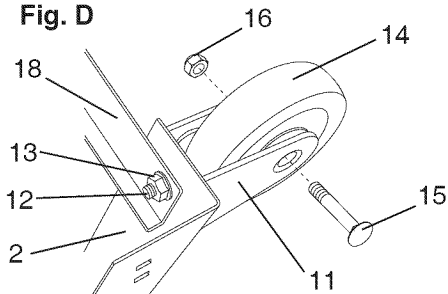
Fig. C



## ASSEMBLE THE ROLLER WHEEL TO STAND (FIG. D, E)

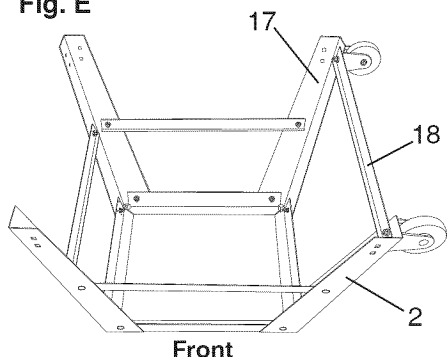
1. Place stand upside down on level surface or floor.
2. Place bottom support bracket for roller wheel (18) inner of the front leg (2).
3. Insert the bolt (12) through the roller wheel bracket (11), front leg (2), bottom support bracket (18) and nut (13) as shown. Tighten the nut.
4. Attach the roller wheel (14) to roller wheel bracket (11), bolt (15) and lock nut (16) using square neck bolt (15) and lock nut (16) as shown.

**NOTE:** Do not overtighten nut as this will not allow the wheels to turn.

**Fig. D**

5. Repeat steps 1-4 for left rear leg (17) and roller wheel assembly.

**NOTE:** The roller wheel assemblies and bottom support bracket (18) can be installed on either the right-hand side or left-hand side. Always install the roller wheel assemblies and the bottom support bracket (18) at the same time. The illustration shows the roller wheels on the left-hand side.

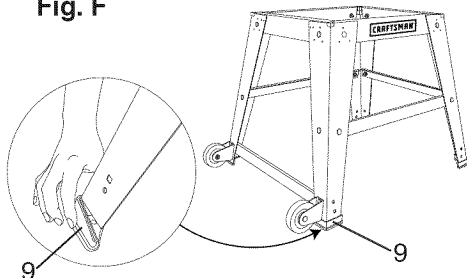
**Fig. E**

6. Carefully set the saw in its upright position on a clean level surface.

### ASSEMBLE THE FOOT PAD TO STAND (FIG. F)

1. Place all four foot pads (9) onto each leg.
2. Place stand on level surface and adjust so all legs are contacting the floor and are at similar angles to the floor, and detents in stand leg align with support brackets, then tighten all bolts.

**NOTE:** Stand should not rock after all bolts are tightend.

**Fig. F**

### ASSEMBLE TABLE SAW TO STAND USING LEVER LOCK (FIG. G)

1. Attach the locking lever assembly (18) to the top of the leg (2).
2. Lift up the locking lever (19).
3. Thread the two screws (20) into the holes (21) of the locking bracket (24) and stand.

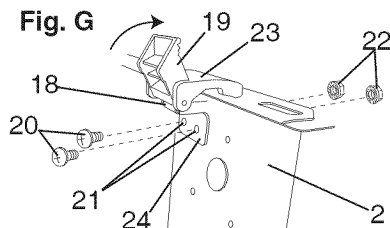
**NOTE:** You may need to loosen the two short support brackets if the two mounting holes are not lined up correctly. Retighten these bolts once you have added the lever locks.

4. Attach the lock nuts (22) and tighten with a 8 mm or adjustable wrench.
5. Install the other locking lever assemblies in exactly the same manner.
6. Position the saw base on the stand.
7. Line up the lever lock cover (23) to the saw base and push down the locking lever (19).
8. Fasten saw to stand using four locking lever assemblies (18).

**NOTE:** The four locking lever assemblies (18) are provided for quick releasing the table saw to the stand.

### **▲ WARNING**

All four levers must be locked in the down position before operating saw.

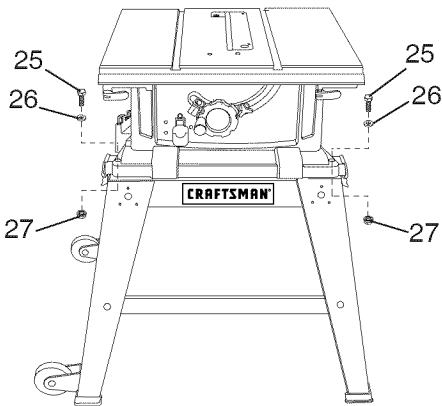
**Fig. G**

## MOUNTING BASE TO STAND USING BOLTS (FIG. H)

You can also attach the saw base to the stand using standard bolts.

1. Fasten the base to the stand using the four long bolts (25), flat washers (26), and nuts (27).
2. Place a washer on the bolt and insert thru the hole in saw base and slot in stand. Attach the nut and tighten using a 13 mm wrench. Repeat for other three corners.

Fig. H



## SAW MOUNTED TO WORK SURFACE (FIG. I)

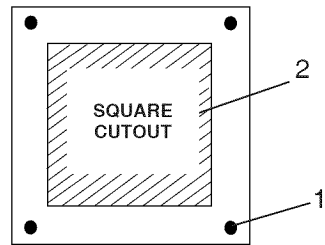
1. If the leg set will not be used, the saw must be properly secured to a sturdy workbench using the four mounting holes at the base of the saw.
2. The surface of the table where the saw is to be mounted must have a hole large enough to facilitate sawdust fall-through and removal.
3. Square the saw on the mounting surface and mark the location of the four 3/8 in. mounting holes (1).
4. Drill 3/8 in. hole into the mounting surface.

5. Mark an 11 in. square (2) centered between the four mounting holes (1).
6. Cut out and remove the square.
7. This opening will allow sawdust to fall through the saw base.
8. Place the saw on the work surface, and align the mounting holes of the saw with those drilled through the surface.
9. Fasten the saw to the work surface.

## **▲ WARNING**

**Do not operate this machine on the floor. This is very dangerous and may cause serious injury.**

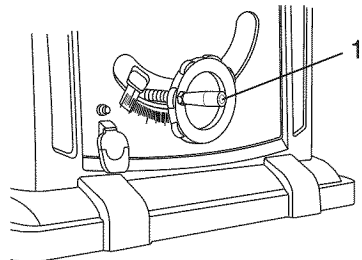
Fig. I



## ASSEMBLING THE HANDWHEEL HANDLE (FIG. J)

Thread the handwheel handle (1) into the handwheel hole, and then tighten the nut against the handwheel with a 14 mm or adjustable wrench.

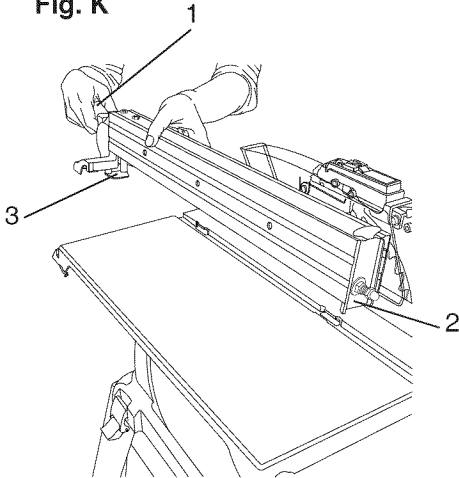
Fig. J



## RIP FENCE (FIG. K)

1. Lift upward on the rip fence handle (1) so the rear holding clamp (2) is fully extended.
2. Place the rip fence on the saw table, and attach the set plate (3) under the fence handle (1) to the rail first.
3. Push down on the fence handle (1) to lock.

Fig. K



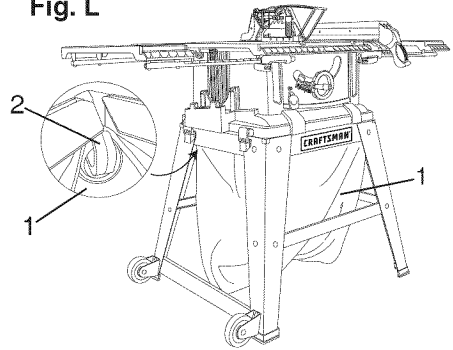
## INSTALLING THE DUST BAG (FIG. L)

### ▲ WARNING

- Do not use this saw to cut and/or sand metals. The hot chips or sparks may ignite sawdust or the bag material.
- To prevent hazard, clean and remove sawdust from under the saw frequently.

1. The hooks (2) located inside of the four legs are used to hold the dust bag (1).
2. Attach the dust bag (1) to the four hooks located inside of four legs.

Fig. L



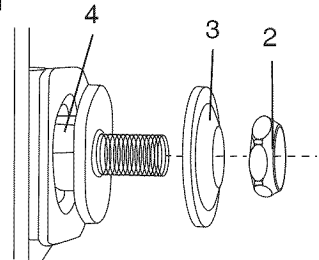
## INSTALLING THE BLADE (FIG. M, N, O)

### ▲ WARNING

To avoid injury from an accidental start, make sure the switch is in the OFF position and the plug is not connected to the power source outlet.

1. Raise the blade arbor to the maximum height by turning the blade elevation handwheel clockwise.
2. Remove the arbor nut (2) and outer blade flange (3). (Fig. M)

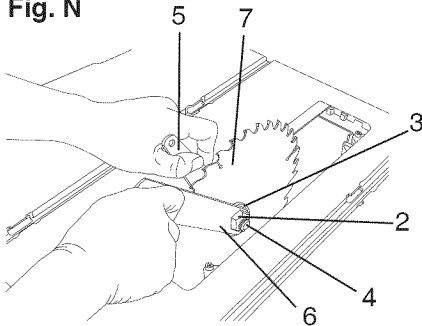
Fig. M



3. Place the blade onto the arbor (4) with the blade teeth pointing forward to the front of the saw. (Fig. N)
4. Make sure the blade fits flush against the inner flange.
5. Clean the outer blade flange (3) and install it onto the arbor (4) and against the blade. (Fig. N)

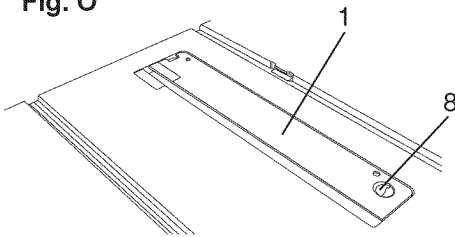
6. Thread the arbor nut (2) onto the arbor, making sure the flat side of the nut is against the blade, then hand-tighten. (Fig. N)
7. To tighten the arbor nut (2), place the open-end wrench (5) on the flats of the saw arbor to keep the arbor from turning (Fig. N).
8. Place the box-end wrench (6) on the arbor nut (2) and turn clockwise (to the rear of the saw table). (Fig. N)

**Fig. N**



10. Lower the blade to its minimum height position and place insert (1) into position. (Fig. O)

**Fig. O**



**⚠ WARNING**

To avoid possible injury and damage to the workpiece, be sure to **INSTALL THE BLADE WITH THE TEETH POINTING TOWARD THE FRONT OF TABLE** in the direction of the rotation arrow on the blade guard.

**REMOVING THE BLADE (FIG. N, O)**

**⚠ WARNING**

To avoid injury from an accidental start, make sure the switch is in the **OFF** position and the plug is disconnected from the power source outlet.

1. Remove the table insert by snapping out from the hole (8). (Fig. O)
2. Raise the blade to the maximum height by turning the blade elevation handwheel clockwise .
3. Adjust the blade to the 90° vertical position by unlocking the blade tilting lock knob and turning the bevel tilting handwheel counterclockwise, and then lock into position.
4. Place the blade wrench (6) on the arbor nut (2) (Fig. N).
5. Loosen the arbor nut (2), place the open-end wrench (5) on the flats of the saw arbor to keep the arbor from turning (Fig. N).
6. Then remove the blade (7). Clean but do not remove the inner blade flange before reassembling the blade (Fig. N).

**RIVING KNIFE ASSEMBLY (FIG. P, P-1, Q)**

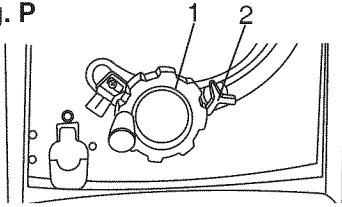
**⚠ WARNING**

- To avoid injury from an accidental start, make sure the switch is in the **OFF** position and the plug is disconnected from the power source outlet.
- Never operate this saw without the riving knife in the correct position.

## Installing the riving knife assembly (Fig. P, P-1)

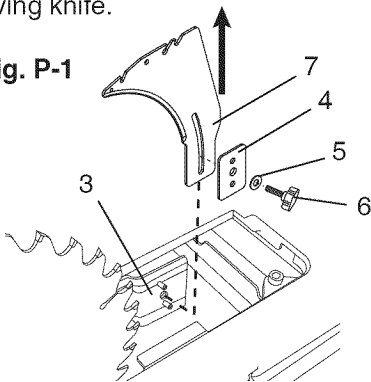
1. Remove the table insert
2. With the blade elevation handwheel (1), raise the blade arbor to the maximum height.
3. Loosen the blade lock handle (2). Just turn and move the handwheel (1) to 45° on the bevel scale.
4. Tighten the bevel lock handle.

Fig. P



5. Take the lock knob (6) and insert thru the washer (5), middle hole in the set plate (4) and slot in riving knife (7).
6. Place this assembly through the mounting bracket (3) located behind the saw blade. Please note that the two pins on the bracket must be engaged in the riving knife slot and the two holes in the set plate.
7. Make sure the riving knife (7) is in its highest position. Tighten the lock knob (6).
8. Return the blade to 0° and place the table insert in position.
9. Before using the saw, please follow the instructions on aligning the riving knife.

Fig. P-1



## Aligning the riving knife (Fig. Q)

### **▲ WARNING**

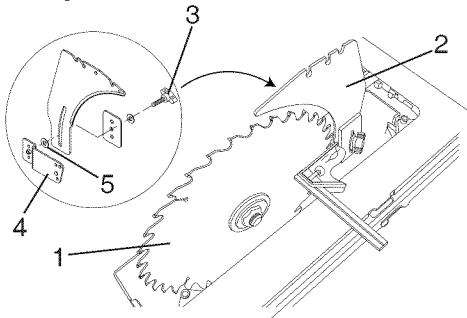
- To avoid injury from an accidental start, make sure the switch is in the OFF position and the plug is disconnected from the power source outlet.
- Never operate this tool without the riving knife in the correct position.
- Never operate this tool without the blade guard in place for all through sawing operations.
- This adjustment was made at the factory, but it should be rechecked and adjusted if necessary.

1. Remove the table insert and raise the blade to the maximum height by turning the blade elevation handwheel clockwise.
2. Remove the blade guard and anti-kickback pawl assembly.
3. Adjust the blade to the 0° vertical position by unlocking the blade tilting lock knob and turning the bevel tilting handwheel counterclockwise, and then lock into position.
4. To see if the blade (1) and riving knife (2) are correctly aligned, lay a combination square along the side of the blade and against the riving knife (making sure the square is between the teeth of the blade).
5. Tilt the blade to the 45° position and check the alignment again.
6. If the blade and riving knife are not correctly aligned:
  - a. Loosen the locking knob (3) from the mounting bracket (4).
  - b. Insert the washer (5) between the riving knife and bracket (4) and retighten the locking knob (3).

**NOTE:**

- The washers (1/4\*1/2-3/32) (5) are not included with this table saw. It must be purchased separately.
  - Riving knife thickness is 0.09 in.
  - The maximum radial distance between the riving knife and the toothed rim of the saw blade is 0.12 in ~ 0.31 in. (3 mm ~ 8 mm)
  - The tip of the riving knife shall not be lower than 0.04 in. ~ 0.2 in. (1 mm ~ 5 mm) from the tooth peak.
  - The riving knife is thinner than the width of the kerf by approximately 1/64 in on each side.
8. Check the riving knife and blade alignment again at both 0° and 45°.
9. Add or remove the washers until the alignment is correct.
10. Replace the table insert, blade guard and anti-kickback pawl assembly.

**Fig. Q**



**BLADE GUARD ASSEMBLY  
(FIG. R, S, T)**



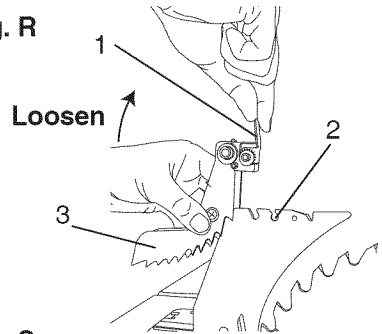
**To avoid injury from an accidental start, make sure the switch is in the OFF position and the plug is disconnected from the power source outlet.**

- When installing the blade guard, cover the blade teeth with a piece of folded cardboard to protect yourself from possible injury.
- Never operate this machine without the blade guard in place for all through sawing operations.

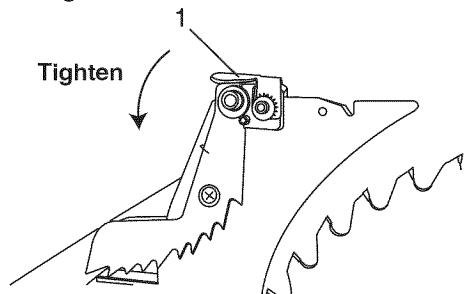
**Installing the blade guard and anti-kickback pawl assembly (Fig. R, S, T)**

1. Make sure the blade is elevated to its maximum height and the bevel is set at 0°. Make sure the bevel lock handle is tight.
2. Take the anti-kickback pawl assembly and lift up the locking lever (1) located on top. (Fig R)
3. Place the front of assembly into slot (2-Fig R) and push down making sure the assembly is engaged in the slots. There should be no movement of the assembly. Push down on the locking lever (1). (Fig S)

**Fig. R**

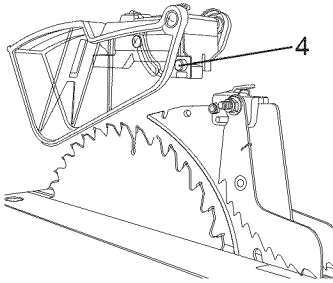


**Fig. S**



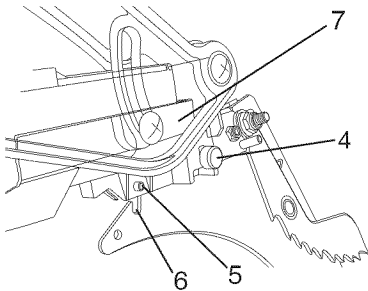
4. Take the blade guard assembly and locate the black sliding locking knob (4) on the back of assembly. (Fig. T)

Fig. T



5. Insert the blade guard assembly onto the riving knife so that the pin (5) engages into slot (6) completely. (Fig T-1)
6. Slide the locking knob (4) up and press the guard assembly down so that the entire assembly is flat on the riving knife. Release the locking knob (4).
7. Make sure that the assembly is locked in place both in front and back.

Fig. T-1



### Removing the blade guard and anti-kickback pawl assembly (Fig. R, T-1)

#### **▲ WARNING**

To avoid injury from an accidental start, make sure the switch is in the OFF position and the plug is disconnected from the power source outlet.

1. With the blade elevation handwheel raise the blade to the maximum height.

2. Loosen the blade lock handle do not pull on handle just turn and move the handwheel to 90° on the bevel scale.
3. Tighten the bevel lock handle.
4. Remove the anti-kickback pawl assembly (3) by pressing the anti-kickback pawls lever (1). (Fig. R)
5. Removing the blade guard assembly (7) by pulling out the locking pin (4). (Fig. T-1)

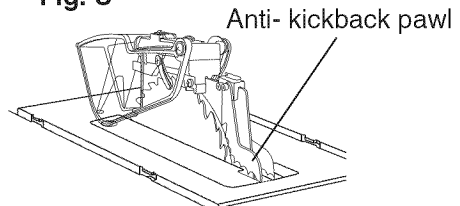
### AVOID KICKBACKS (FIG. U)

(Work thrown back towards you) by keeping the blade sharp, the rip fence parallel to the saw blade and by keeping the riving knife, anti-kickback pawls and guards in place, aligned and functioning. Do not release work before passing it completely beyond the saw blade. Do not rip work that is twisted, warped or does not have a straight edge to guide it along the fence. Do not attempt to reverse out of a cut with the blade running.

#### **▲ WARNING**

Improper riving knife alignment can cause “kickback” and serious injury.

Fig. U



### INSTALLING TABLE SIDE EXTENSIONS (FIG. V)

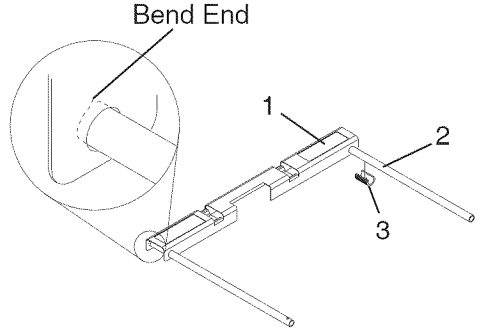
1. Identify the right hand table extension.  
**NOTE:** For illustration purposes the view in Fig. V looks “through” the saw table to the under side of the table. The right hand table extension is the one with the measuring scale visible from the front of the saw when it is installed to the right hand side of the saw table.

- Unlock both front and rear cam locking levers (1) on the right hand side of the saw base by flipping the lever over.
- Insert the table extension mounting tubes (2) into the two matching holes in the cam lever assemblies.
 

**NOTE:** Make sure the front mounting tube has the measuring scale visible from the front of the saw.
- Slide the table extension toward the table until it rests against the saw table.
- Lock both cam locking levers by pushing them in toward the cam locking lever assemblies.
- If the extension is not level to the table, adjust by inserting the spacers (Carton Contents S) between the extension and the tube it mounts onto. See page 35.

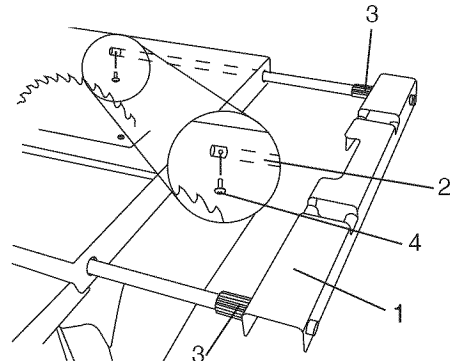
- Snap two black plastic stops (3) over the two rear table extension tubes (2). Make sure the locating pin in the black plastic stops fits into the matching hole in the extension tube. This will 'lock' the tube into the extension. (Fig. W)

**Fig. W**



- Insert the rear table extension tubes (2) into the two holes in the rear of the saw table, and into the extension tube brackets under the table. Position the rear table support so that the instruction labels are facing up. (Fig. X)
- Tighten one extension wing stop screw (4) on the end of the left rear table extension tubes (2). Verify that the screw is fully inserted into the corresponding hole in the extension tube. (Fig. X)

**Fig. X**



- Make sure the screw (3) into the matching hole (4) of the extension mounting tube (2).
- Install the left hand table extension the same manner.

## INSTALLING THE REAR TABLE EXTENSION (FIG. W, X)

- Insert the two rear table extension tubes (2) into the rear table extension (1).
 

**NOTE:** They must be inserted into the back of the extension with the bent end last so that the bar will hold the extension in place. (Fig. W)

## ADJUSTING THE REAR TABLE EXTENSION (FIG. X)

1. The rear table extension (1) should be positioned as close as possible to the rear of the table when ripping short material.
2. The rear table extension (1) should be fully extended when ripping longer materials that require extra support.

## INSTALLING THE BATTERIES FOR THE LASER LINE (FIG. Y)

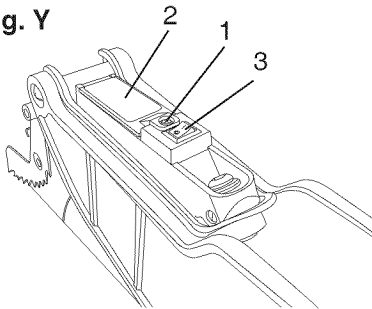
### **▲ WARNING**

Failure to unplug your saw could result in accidental starting causing possible serious personal injury.

1. Remove the locking screw (1) on the cover of the battery compartment with a Phillips screwdriver, and open the battery compartment.
2. Install two “AAA” batteries.
3. Close the cover (2), and replace the locking screw and tighten it securely.
4. Turn the switch (3) to the ON position in order to activate the laser cutting guide.

**NOTE:** See instructions on Adjusting The Laser Line on page 33.

Fig. Y

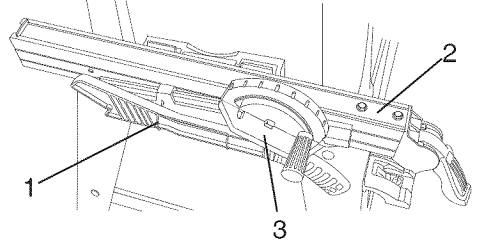


## INSTALLING THE PUSH-STICK STORAGE HOLDER (FIG. Z)

Attach the metal push-stick storage bracket (1) into the provided slots on

the left side of the body shell. The bracket will snap into place.

Fig. Z



## STORAGE (FIG. Z, AA, BB)

### Rip fence, miter gauge (Fig. Z)

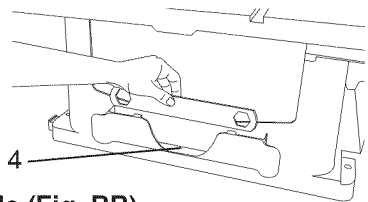
Storage brackets for the rip fence (2) and miter gauge (3) are located on the left side of the saw housing.

**NOTE:** Adjust the miter gauge to 45°~60° before putting away in storage.

### Blade Wrench (Fig. AA)

Insert the blade wrench into the slot (4) located to the back side of the saw housing.

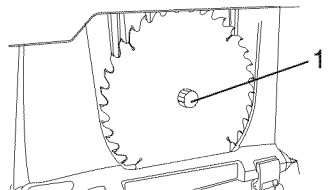
Fig. AA



### Blade (Fig. BB)

1. Loosen and remove the knob (1) on the left side of the saw housing.
2. Place extra blades (not included) onto the arbor. Replace the knob and tighten.

Fig. BB

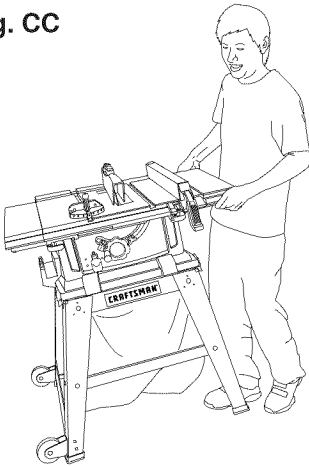


# ADJUSTMENTS

## MOVE THE TABLE SAW (FIG. CC)

1. Slide the table extension toward the table until it rests against the saw table and tighten the two cam-locking levers.
2. Hold the table saw firmly, pull the table saw toward you until the saw is balanced on the wheels.
3. Move the saw to the desired location for operation or store the saw in a dry environment.

Fig. CC



## RIP FENCE ADJUSTMENT (FIG. DD)

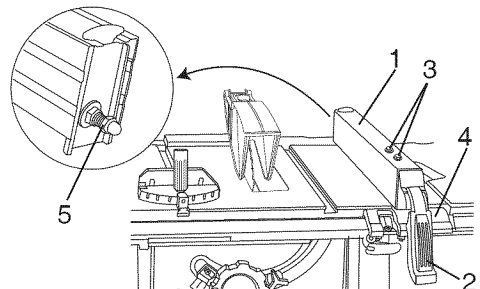
1. The fence (1) is moved by lifting up on the handle (2) and sliding the fence to the desired location. Pushing down on the handle locks the fence in position.
2. Position the fence on the right side of the table and along the edge miter gauge groove.
3. Lock the fence handle. The fence should be parallel with the miter gauge groove.

4. If adjustment is needed to make the fence parallel to the groove, do the following:
  - Loosen the two bolts (3) and lift up on the handle (2).
  - Hold the fence bracket (4) firmly against the front of the saw table. Move the fence until it is parallel with the miter gauge groove.
  - Push the handle down and tighten both bolts.
5. If fence is loose when the handle is in the locked (downward) position, do the following:
  - Move the handle (2) upward and turn the adjusting nut (5) clockwise until the rear clamp is snug.
  - Over-tightening the adjusting bolts will cause the fence to come out of alignment.

### **WARNING**

Failure to properly align fence can cause “kickback” and serious injury.

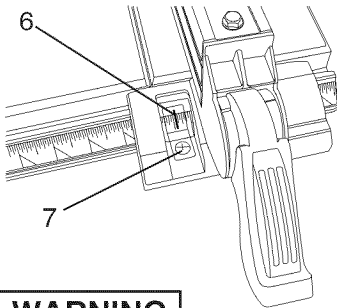
Fig. DD



## RIP FENCE INDICATOR ADJUSTMENT (FIG. EE)

1. The rip fence indicator (6) points to the measurement scale. The scale shows the distance from the side of the fence to nearest side of the blade.
2. Measure the actual distance with a rule. If there is a difference between the measurement and the indicator, adjust the indicator (6).
3. Loosen the screw (7) and slide the indicator to the correct measurement on the scale. Tighten the screw and remeasure with the rule.

Fig. EE



### **⚠ WARNING**

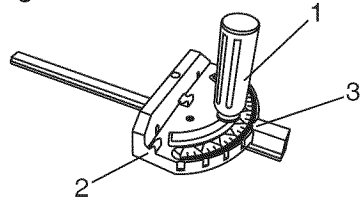
To avoid injury from an accidental start, make sure the switch is in the OFF position and the plug is not connected to the power source outlet.

## ADJUSTING THE MITER GAUGE (FIG. FF)

1. Loosen the lock handle (1) to allow the miter body (2) to rotate freely. Position the miter body at 90° so the positive detent secures its position. Tighten the lock handle to hold the miter body in position.
2. If the pointer (3) requires adjustment, loosen the screw under the pointer with a screwdriver. Adjust the pointer to 90° on the scale, then firmly tighten the adjustment screw.

3. To change angles on the miter gauge, loosen the lock handle (1) and rotate the miter body to the desired angle as indicated by the scale. Secure in position by tightening the lock handle.

Fig. FF



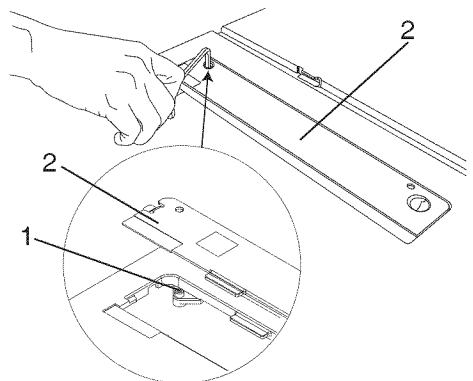
## ADJUSTING THE TABLE INSERT (FIG. GG)

### **⚠ WARNING**

To avoid serious injury, the table insert (2) must be level with the table. If the table insert is not flush with the table, adjust the two bolts (1) with a 4 mm hex wrench until it is parallel with the table.

**NOTE:** To raise the insert, turn the hex screws counterclockwise, to lower the insert, turn the hex screws clockwise. Do not remove the insert, adjustments need to be made with the insert in place to get the proper level.

Fig. GG



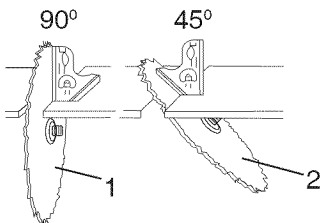
## ADJUSTING THE 90° AND 45° POSITIVE STOPS (FIG. HH, II)

Your saw has positive stops that will quickly position the saw blade at 90° and 45° to the table. Make adjustments only if necessary.

### 90° Stop

1. Disconnect the saw from the power source.
2. Raise the blade to the maximum elevation.
3. Loosen the blade bevel lock handle and move the blade to the maximum vertical position and tighten the bevel lock handle.
4. Place a combination square on the table and against the blade (1) to determine if the blade is 90° to the table. (Fig. HH)
5. If the blade is not 90° to the table, loosen or tighten (depending on whether you are increasing or decreasing the degrees) the hex bolt (3) with a 5 mm hex wrench until you achieve 90°. (Fig. II)
6. Loosen the bevel lock handle and reset the blade at the maximum vertical position, then tighten the bevel lock handle.
7. Check again to see if the blade is 90° to the table. If not, repeat step 5.
8. Lastly, check the bevel angle scale. If the pointer does not read 90°, loosen the screw holding the pointer and move the pointer so it is accurate at 90° and retighten the pointer screw.

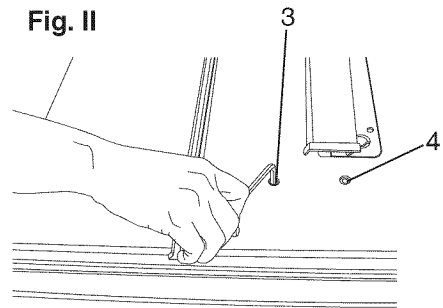
Fig. HH



### 45° Stop

1. Disconnect the saw from the power source.
2. Raise the blade to the maximum elevation.
3. Loosen the blade bevel lock handle and move the blade to the maximum bevel position (45°) and tighten the bevel lock handle.
4. Place a combination square on the table and against the blade (2) to determine if the blade is 45° to the table. (Fig. HH)
5. If the blade is not 45° to the table, loosen or tighten (depending on whether you are increasing or decreasing the degrees) the hex bolt (4) with a 5 mm hex wrench until you achieve 45°. (Fig. II)
6. The, loosen the bevel lock handle and reset the blade at the maximum bevel position (45°), then tighten the bevel lock handle.
7. Check again to see if the blade is 45° to the table. If not, repeat step 5.

Fig. II



### BLADE TILT POINTER

1. When the blade is positioned at 90°, adjust the blade tilt pointer to read 0° on the scale.
  2. Loosen the holding screw, position the pointer over 0° and tighten the screw.
- NOTE:** Make a trial cut on scrap wood before making critical cuts. Measure for exactness.

## BLADE PARALLEL TO THE MITER GAUGE GROOVE (FIG. JJ, KK)

### **⚠ WARNING**

This adjustment was made at the factory, but it should be rechecked and adjusted if necessary.

### **⚠ WARNING**

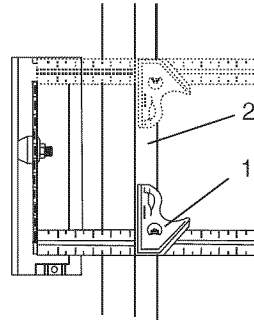
To prevent personal injury:

- Always disconnect plug from the power source when making any adjustments.
- This adjustment must be correct or accurate cuts can not be made. Also inaccurate adjustment can result in kickback and serious personal injury.

1. Remove the safety switch key and unplug the saw.
2. Remove the blade guard for this procedure but reinstall and realign after adjustment.
3. Raise the blade to the highest position and set at the 0° angle (90° straight up).
4. Select and mark, with a felt tip maker, a blade tooth having a “right set” and rotate the blade so the marked tooth is 1/2 in. above the table.
5. Place the combination square base (1) into the right side miter gauge groove (2). (Fig. JJ)
6. Adjust the rule so it touches the front marked tooth and lock ruler so it holds its position in the square assembly.
7. Rotate the blade bringing the marked tooth to the rear and about 1/2 in. above the blade.
8. Carefully slide the combination square to the rear until the ruler touches the marked tooth.

9. If the ruler touches the marked tooth at the front and rear position, no adjustment is needed at this time. If not or the base of the rule is no longer parallel with the edge of the miter gauge groove, perform adjustment procedure described in next section.

Fig. JJ



## ADDITIONAL BLADE ADJUSTMENTS (FIG. KK)

**NOTE:** The adjusting mechanism is located above the blade height adjusting hand wheel under the tabletop. If the front and rear measurements are not the same.

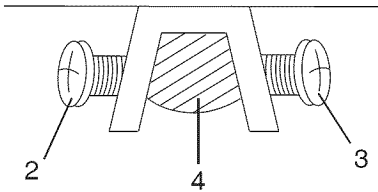
### **If the blade is partial to right side:**

1. Turn the left adjustment screw (2) counterclockwise and adjust the right side adjustment screw (3) clockwise.
2. Remeasure, as described in steps 4 to 9 in the prior section.
3. When alignment is achieved, turn the left adjustment screw (2) until it touches the pivot rod (4).

### If the blade is partial to left side:

1. Turn the right adjustment screw (3) counterclockwise and adjust the left side adjustment screw (2) clockwise.
2. Remeasure, as described in steps 4 to 9 in the prior section.
3. When alignment is achieved, turn the right adjustment screw (3) until it touches the pivot rod (4).

Fig. KK



## THE LASER LINE

This tool is equipped with the Laser Trac®, which is a battery-powered laser cutting guide. The laser line allows the operator to anticipate the path of the saw blade on the workpiece before cutting begins.

### **▲ WARNING**

**The laser beam is emitted when the laser line is turned on. Do not stare into the beam or view it directly using optical instruments. Do not remove the warning label that is affixed to the blade guard. Avoid aiming the laser beam directly into the eyes.**

- A laser beam is not a toy, and it should not be used by children. Misuse of this laser line can lead to irreparable eye damage.

- Do not perform any adjustments that are intended to increase the power of the laser.
- When using the laser line, do not point the laser beam at people and/or reflecting surfaces. Even a low-intensity laser beam can cause eye damage. Do not look directly into the laser beam.
- If the Laser Line will not be used for more than three months, remove the batteries in order to avoid damage from possible leakage.
- The laser line does not include any user-serviceable components. Do not open the housing in an attempt to repair it.
- Repairs should only be carried out at a service center or by an authorized service technician.
- **NOTE:** All the adjustments for the operation of this machine have been completed at the factory. Due to normal wear and use, some occasional readjustments may be necessary.
- **CAUTION-**Use of controls or adjustments or performance of procedures other than those specified herein may result in hazardous radiation exposure.
- **CAUTION-**The use of optical instruments with this product will increase eye hazard.
- Do not attempt to repair or disassemble the laser. If unqualified persons attempt to repair this laser product, serious injury may result. Any repair required on this laser product should be performed by authorized service center personnel.

## LASER RADIATION.

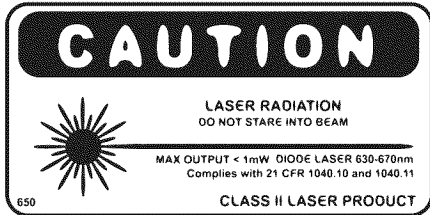
Do not stare into the beam or view it directly using optical instruments.

Maximum output: < 1 mW

Wavelength: 630-670 nm

Complies with 21 CFR 1040.10 and 1040.11 Class II Laser Product.

Laser Warning Label:



## ADJUSTING THE LASER LINE (FIG. LL)

### WARNING

The laser beam is emitted when the laser line is turned on. Do not stare into beam or look directly at it using optical instruments. Do not remove the warning label that is affixed to the blade guard. Do not direct the laser into the eyes.

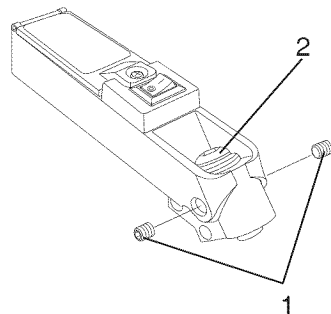
**NOTE:** All of the adjustments for the operation of this machine have been carried out at the factory. Occasional readjustments may be necessary as a result of normal wear and use.

1. Turn the laser line on. Place a straight edge or ruler against the right side of the blade.
2. Verify whether the laser line is flush against the right side of the blade, and against the straight edge or ruler.

3. If the laser line is not flush, loosen the two set screws (1) using a small flat bladed screwdriver that is not provided, but do not remove them.
4. Use the 5 mm hex wrench that is not provided, adjust the laser unit (2) until the laser line is parallel with the blade. **NOTE:** Be careful not to over-rotate the laser unit. Do not rotate the laser more than 1/8 of a turn in either direction.
5. Adjust the set screws (1) on the left or right side in order to shift the laser line until it is flush with the right side of the blade. Once proper alignment has been achieved, tighten the set screw on the other side slowly, until it touches the laser, in order to lock the laser into position. Turn the laser line off.

**NOTE:** If additional alignment is required, use thin flat washers (not provided) by placing them between the riving knife and the mounting bracket. Refer to the section of "Aligning the riving knife" on page 23.

Fig. LL



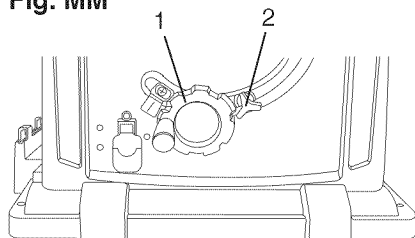
# OPERATION

## BASIC SAW OPERATIONS

### RAISE THE BLADE (FIG. MM)

To raise or lower the blade, turn the blade elevation handwheel (1) to the desired blade height, and then tighten the bevel lock handle (2) to maintain the desired blade angle.

Fig. MM



### TILTING THE BLADE

Two methods are available for tilting the saw blade.

#### Rapid blade tilting:

Loosen the bevel lock handle (2), move the handwheel (1) to the desired angle, then tighten the bevel lock handle.

#### Fine adjustment blade tilting:

Loosen the bevel lock handle (2), push in the handwheel (1) and at the same time turn the handwheel (1) to tilt the saw blade. When the saw blade is at the desired angle, tighten the bevel lock handle (2).

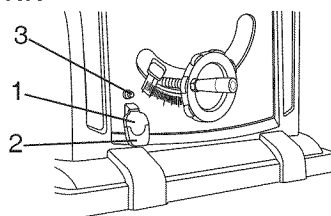
### ON/OFF SWITCH (FIG. NN)

The ON / OFF switch has a safety removal key. With the key removed from the switch, unauthorized and hazardous use by children and others is minimized.

1. To turn the saw ON, insert the safety switch key (1) into the slot in the switch (2). Move the switch upward to the ON position.

2. To turn the saw OFF, move the switch downward.
3. To lock the switch in the OFF position, grasp the end (or yellow part) of the safety switch key (1), and pull it out.
4. With the safety removal key removed, the switch will not operate.
5. If the safety removal key is removed while the saw is running, it can be turned OFF but cannot be restarted without inserting the switch key (1).

Fig. NN



### OVERLOAD PROTECTION (FIG. NN)

This saw has an overload reset button (3) that resets the motor after it shuts off due to overloading or low voltage. If the motor stops during operation, turn the ON / OFF switch to the OFF position. Wait about five minutes for the motor to cool, then push the reset button (3) and turn the switch to the ON position.

### **⚠ WARNING**

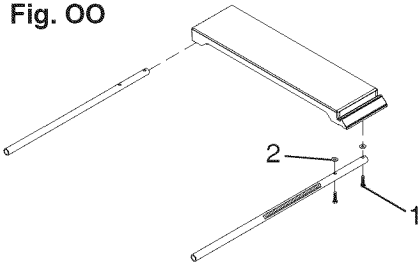
**To avoid injury, the ON / OFF switch should be in the OFF position and the plug removed from the power source while the cool down takes place, to prevent accidental starting when the reset button is pushed. Overheating may be caused by misaligned parts or a dull blade or undersized extending cord. Inspect your saw for proper setup before using it again.**

## USING THE TABLE EXTENSION (FIG. OO, PP)

If the table extension is not parallel with the table, remove the bolts (1) and position the extension leveling spacers (2) between the table extension and tube until it is parallel with the table, then tighten the bolts.

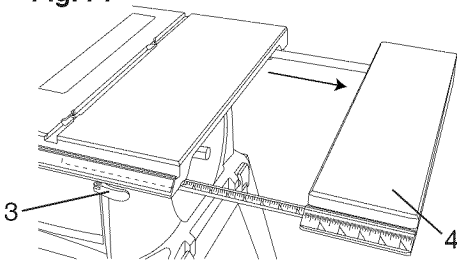
**NOTE:** See page 14 for table of loose parts ITEM: S

Fig. OO



1. Release the extension cam locking levers (3).
2. Slide the extension (4) out until the correct measurement is displayed on the tube scale. The user sights the scale off the edge of the table.
3. Tighten all extension cam locking levers.

Fig. PP



## CUTTING OPERATIONS

There are two basic types of cuts: ripping and crosscutting. Ripping is cutting along the length and the grain of the workpiece. Crosscutting is cutting either across the width or across the

grain of the workpiece. (It is not safe to rip or crosscut by freehand). Ripping requires the use of the rip fence, and crosscutting requires the miter gauge.

**NEVER USE THE TWO AT THE SAME TIME.**

### **▲ WARNING**

Before using the saw each time, check the following:

1. The blade is tightened to the arbor.
2. The bevel angle lock knob is tightened.
3. If ripping, make sure the fence is locked into position and is parallel to the miter gauge groove.
4. The blade guard is in place and working properly.
5. Safety glasses are worn.

The failure to adhere to these common safety rules, and those printed in the front of this manual, can greatly increase the likelihood of injury.

## RIPPING (FIG. QQ, RR)

### **▲ WARNING**

To prevent serious injury:

- Never use a miter gauge when ripping.
- Never use more than one rip fence during a single cut.
- Do not allow familiarity or frequent use of your table saw to cause careless mistakes. Remember that even a careless fraction of a second is enough to cause a severe injury.
- Keep both hands away from the blade and clear from the path of the blade.

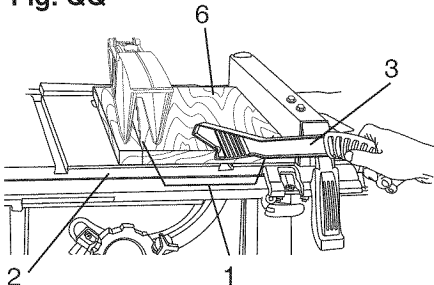
- **The workpiece must have a straight edge against the fence and must not be warped, twisted, or bowed when ripping.**

1. Remove the miter gauge and store it in the “storage” compartment in the base of the saw.
2. Secure the rip fence to the table.
3. Raise the blade so it is about 1/8 in. higher than the top of the workpiece.
4. Place the workpiece flat on the table and against the fence. Keep the workpiece away from the blade.
5. Turn the saw ON and wait for the blade to come to full speed.
6. Slowly feed the workpiece into the blade by pushing forward only on the workpiece section (1) that will pass between the blade and the fence. (Fig. QQ)
7. Keep your thumbs off the table top. When both of your thumbs touch the front edge of the table (2), finish the cut with a push stick (3). To make an additional push stick, use the pattern on page 47. (Fig. QQ)

**▲ WARNING**

**AVOID KICKBACK** by pushing forward on the section of the workpiece that passes between the blade and the fence. Never perform any freehand operations.

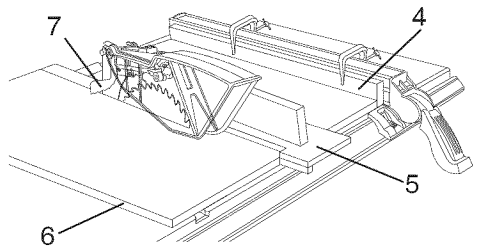
Fig. QQ



**▲ WARNING**

When width or rip narrower than 2 in. the push stick cannot be used because the blade guard will interfere. Use the auxiliary fence (4) and push block (5) as shown.

Fig. RR



8. Continue pushing the workpiece (6) with the push stick (3-Fig. QQ) or push block until it passes through the blade guard and clears the rear of the table. (Fig. RR)
9. Never pull the piece back when the blade is turning. Turn the switch OFF. When the blade completely stops, you can then remove the workpiece.

**▲ WARNING**

Never attempt to pull the workpiece backwards during a cutting operation. This will cause kickback and serious injury to the user can occur. When the blade completely stops, raise the anti-kickback pawls (7) on each side of the riving knife and slide the workpiece out.

## BEVEL RIPPING

This cut is the same as ripping except the blade bevel angle is set to an angle other than "0°".

## RIPPING SMALL PIECES

To avoid injury from the blade contact, never make cuts narrower than 3/4 in. wide.

1. It is unsafe to rip small pieces.  
Instead, rip a larger piece to obtain the size of the desired piece.
2. When a small width is to be ripped, your hand cannot be safely put between the blade and the rip fence, use push stick or push block to pass the workpiece completely through and past the blade.

## HELPFUL DEVICES

In order to make some of cuts, it is necessary to use the devices like, push block, featherboard and auxiliary fence, which you can make yourself. Here are some templates for your reference.

## FEATHERBOARD (FIG. SS, TT)

A featherboard is a device used to help control the workpiece by guiding it securely against the table or fence. Featherboards are especially useful when ripping small workpieces and for completing non-through cuts. The end is angled with a number of short kerfs to give a friction hold on the workpiece and locked in place on the table with C-clamps.

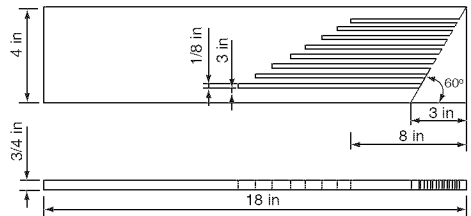
### WARNING

Place the featherboard against the uncut portion of the workpiece to avoid kickback that could cause serious personal injury.

## MAKE A FEATHERBOARD (FIG. SS)

Select a solid piece of lumber approximately 3/4 in thick, 4 in wide and 18 in long. To make a featherboard, cut one end of the lumber at 60 degrees, then cut 8 in-long slots 1/4 in apart on the angled end as shown in Fig. SS.

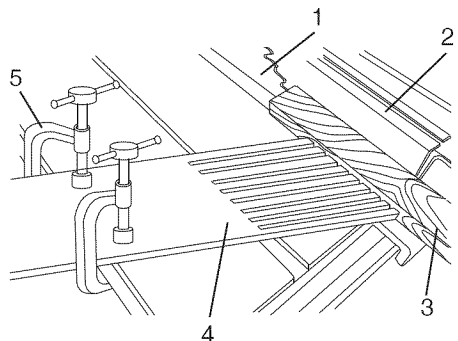
Fig. SS



## USE A FEATHERBOARD (FIG. TT)

1. Lower the saw blade (1).
2. Position the rip fence (2) to the desired adjustment and lock the rip fence.
3. Place the workpiece (3) against the fence and over the saw blade area.
4. Adjust the featherboard (4) to resist the workpiece forward of the blade.
5. Attached the C-clamps (5) to secure the featherboard to the edge of the table.

Fig. TT



## AUXILIARY FENCE (FIG. UU)

### Making the base:

- Start with a piece of 3/8 in. plywood at least 5-1/2 in. wide or wider and 21 in. long or longer.
- Cut the piece to shape and size shown:

### Making the side:

- Start with a piece of 3/4 in. hardwood at least 1-3/4 in. wide or wider and 21 in. long or longer.
- Cut the piece to shape and size shown:

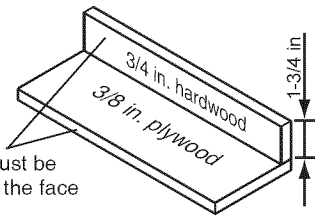
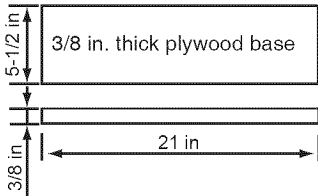
### Putting it together:

- Fasten the pieces together with glue and woodscrews.

### WARNING

Make sure the screw heads do not stick out from the bottom of the base, they must be flush or recessed. The bottom must be flat and smooth enough to rest on the saw table without rocking.

Fig. UU



## PUSH BLOCK

Use for ripping operation when the workpiece is too narrow to use a push stick. Always use a push block for rip widths less than 2 inches.

## MAKE A PUSH BLOCK (FIG. VV)

### Making the base:

- Start with a 3/8 in. plywood at least 5-1/2 in. wide or wider and 12 in. long or longer.
- Cut the piece to shape and size as shown.

### Making the handle:

- Start with a 3/4 in. hardwood at least 5 in. wide or wider and 7 in. long or longer.
- Cut the piece to shape and size as shown.

### Making the bracket:

- Start with a 3/8 in. wood at least 3/8 in. wide or wider and 2-1/2 in. long or longer.
- Cut the piece to shape and size as shown.

### Putting it together:

- Fasten the base and handle together with glue and woodscrews.

### WARNING

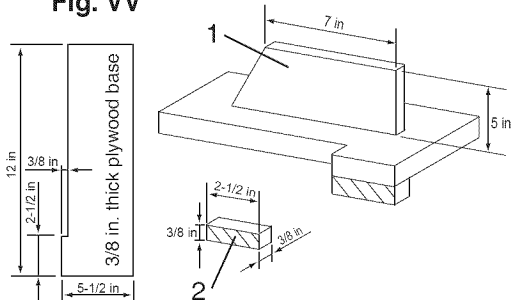
Make sure the screw heads do not stick out from the bottom of the base, they must be flush or recessed.

- Fasten the base and bracket together with glue.

### WARNING

To avoid injury, do not use the screws to fasten the base and bracket.

Fig. VV



## CROSSCUTTING (FIG. WW)

### **⚠ WARNING**

To prevent serious injury:

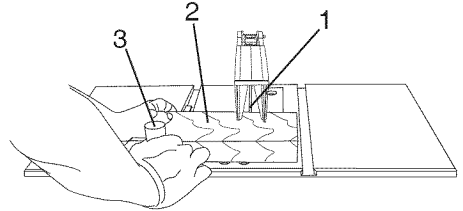
- Do not allow familiarity or frequent use of your table saw to cause careless mistakes. Remember that even a careless fraction of a second is enough to cause a severe injury.
- Keep both hands away from the blade and the path of the blade.
- Never attempt to pull the workpiece backwards during a cutting operation. This will cause kickback and serious injury to the user can occur.

1. Remove the rip fence and place the miter gauge in the miter gauge groove on the table.
2. Adjust the blade height so that it is 1/8 in. higher than the top of the workpiece.
3. Hold the workpiece firmly against the miter gauge with the blade path in line with the desired cut location. Move the workpiece to a 1 in. distance from the blade.
4. Start the saw and wait for the blade (1) to come up to full speed. Never stand directly in line of the saw blade path, always stand to the side of the blade that you are cutting on.
5. Keep the workpiece (2) against the face of the miter gauge (3) and flat against the table. Then slowly push the workpiece through the blade.
6. Do not try to pull the workpiece back with the blade turning. Turn the switch OFF, and carefully slide the workpiece out when the blade has completely stopped.

### **⚠ WARNING**

Always position the larger surface of the workpiece on the table when crosscutting and/or bevel crosscutting to avoid instability.

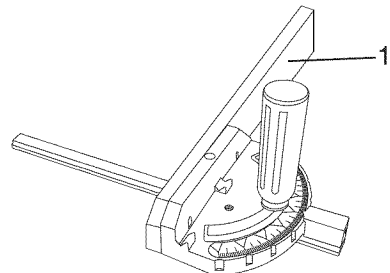
Fig. WW



## USING THE WOOD FACING ON THE MITER GAUGE (FIG. XX)

Slots are provided in the miter gauge for attaching an auxiliary facing (1) to make it easier to cut very long or short pieces. Select a suitable piece of smooth wood, drill two holes through it and attach it to the miter gauge with screws. Make sure the facing does not interfere with the proper operation of the saw blade guard. When cutting long workpieces, you can make a simple outfeed support by clamping a piece of plywood to a sawhorse.

Fig. XX



## BEVEL CROSSCUTTING (FIG. YY)

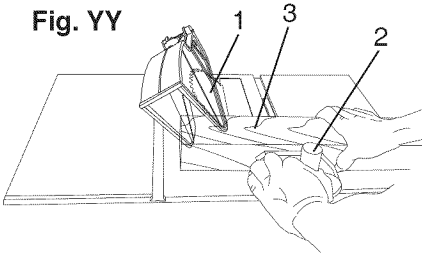
0°~45° BLADE BEVEL & 90° MITER ANGLE This cutting operation is the same as crosscutting except the blade is at a bevel angle other than 0°.

### WARNING

Always work to the right side of the blade during this type of cut. The miter gauge must be in the right side groove because the bevel angle may cause the blade guard to interfere with the cut if used on the left side groove.

1. Lower the blade to the down position.
2. Adjust the blade (1) to the desired angle, and tighten the blade bevel lock knob.
3. Tighten the miter lock handle (2) at 90°.
4. Hold workpiece (3) firmly against the face of the miter gauge throughout the cutting operation.

Fig. YY



## COMPOUND MITER CROSSCUTTING (FIG. ZZ)

0°~45° BLADE BEVEL & 0°~45° MITER ANGLE

This sawing operation combines a miter angle with a bevel angle.

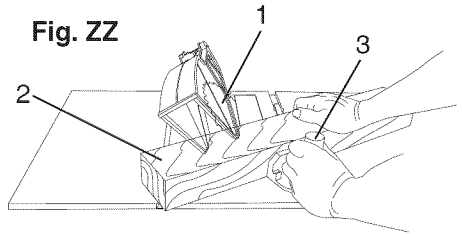
### WARNING

Always work to the right side of the blade during this type of cut. The miter gauge must be in the right side

groove because the bevel angle may cause the blade guard to interfere with the cut if used on the left side groove.

1. Set the miter gauge (3) to the desired angle.
2. Place the miter gauge in the right side groove of the table.
3. Set the blade (1) bevel to the desired bevel angle and tighten the blade bevel lock knob.
4. Hold workpiece (2) firmly against the face of the miter gauge throughout the cutting operation.

Fig. ZZ



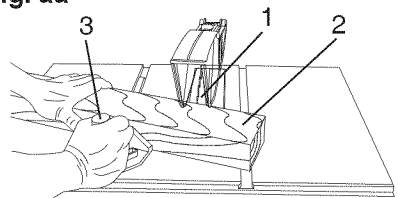
## MITERING (FIG. aa)

0°~45° MITER ANGLE

This sawing operation is the same as crosscutting except the miter gauge is locked at an angle other than 90°.

1. Set the blade (1) to 0° bevel angle and tighten the blade bevel lock knob.
2. Set the miter gauge (3) at the desired miter angle and lock in position by tightening the miter gauge locking handle.
3. Hold the workpiece (2) firmly against the face of the miter gauge throughout the cutting operation.

Fig. aa

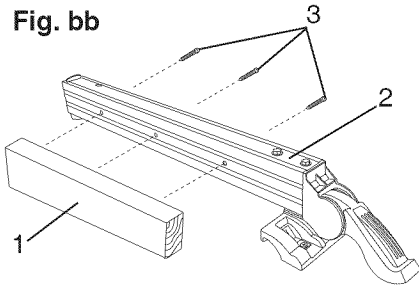


## USING THE WOOD FACING ON THE RIP FENCE (FIG. bb)

When performing some special cutting operations, you can add a wood facing to either side of the rip fence (2).

1. Use a smooth straight 3/4 in. thick wood board (1) that is as long as the rip fence.
2. Attach the wood facing to the fence with wood screws (3) (not included) through the holes in the fence. A wood fence should be used when ripping material such as thin paneling to prevent the material from catching between the bottom of the fence and the table.

Fig. bb



## NON-THROUGH CUT (FIG. cc)

A non-through cut is used to cut grooves and rabbets in the workpiece without exposing the blade.

### **⚠ WARNING**

- Only this type cut is made without install the blade assembly, anti-kickback pawls assembly.
- To avoid injury from an accidental start, make sure the switch is in the OFF position and the plug is disconnected from the power source outlet.

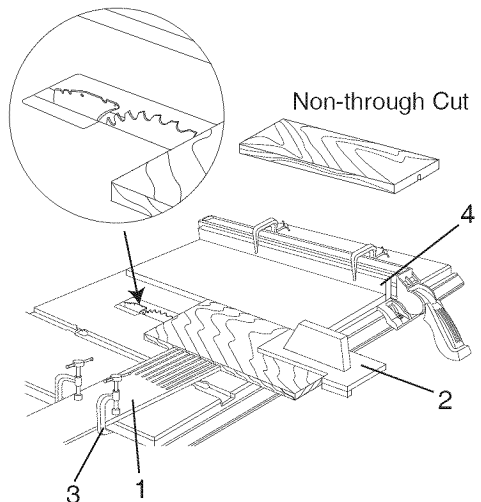
- To avoid the risk of personal injury. Always use push block, auxiliary fence and featherboard when making non-through cut.

1. Before starting the table saw, lower the blade and riving knife assembly to the down position.
2. Remove the blade guard assembly and anti-kickback pawls assembly for non-through cut.
3. Use the featherboard (1) with C-clamps (3) to fasten the workpiece securely.
4. Mount the auxiliary fence (4) with C-clamps.
5. Use the push block (2) to move the workpiece.

### NOTE:

- Mount the featherboard to table as shown, so the leading edges of featherboard will help workpiece complete cutting.

Fig. cc



## DADO CUTS (FIG. dd, ee)

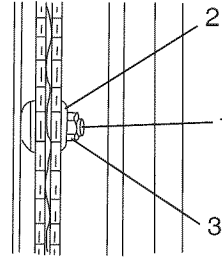
### **▲ WARNING**

- Only Stackable dado blades can be used on this saw.
- DO NOT use Adjustable or Wobble type dados.
- The maximum dado cut width is 1/2 in.

1. Remove the table insert, saw blade, anti-kickback pawl assembly, blade guard assembly and riving knife assembly for dado cuts ONLY. Reinstall and realign blade guard for all through-sawing operations. Install a dado not exceeding 6 in. in diameter and 1/2 in. in width
2. Install the dado table insert making sure that the rear of the insert is flush with the table. If the dado insert is not flush with the table, adjust the two bolts on the insert with a 4 mm hex wrench until it is parallel with the table.
3. Instructions for operating the dado is packed with the separately purchased dado set.
4. The arbor (1) on this saw restricts the maximum width of the cut to 1/2 in.
5. It is not necessary to install the outside flange (2) before threading on the arbor nut (3) for the maximum 1/2 in. dado cuts. Make sure that the arbor nut (3) is tight, and that at least one thread of the arbor sticks out past the nut.
6. Use only the correct number of round outside blades and inside

chippers as shown in the dado set's instruction manual. Blade/chippers must not exceed 1/2 in. total in width.

Fig. dd

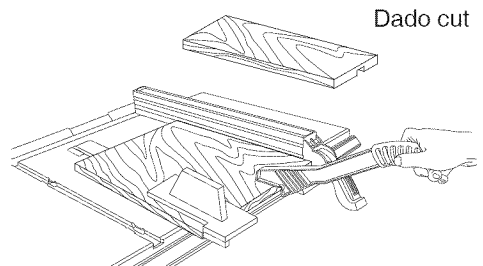


7. Check the saw to ensure that the dado will not strike the housing, insert, or motor when in operation.

### **▲ WARNING**

For your own safety, always replace the blade, blade guard assembly, anti-kickback pawl assembly, riving knife assembly and table insert when you finished the dado operation.

Fig. ee



# MAINTENANCE

## MAINTAINING YOUR TABLE SAW

### GENERAL MAINTENANCE

#### **⚠ WARNING**

**For your own safety, turn the switch OFF and remove the switch key. Remove the plug from the power source outlet before maintaining or lubricating your saw.**

1. Clean out all sawdust that has accumulated inside the saw cabinet and the motor.
2. Polish the saw table with an automotive wax to keep it clean and to make it easier to slide the workpiece.
3. Clean cutting blades with pitch and gum remover.
4. A worn, cut, or damaged power cord should be replaced immediately.

#### **⚠ WARNING**

**All electrical or mechanical repairs should be attempted only by a trained repair technician. Contact customer service for assistance. Use only identical replacement parts. Any other parts may create a hazard.**

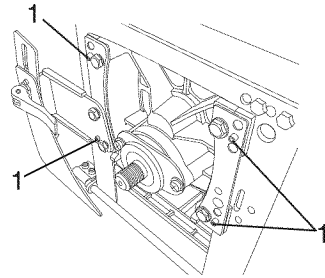
5. Use liquid dishwashing detergent and water to clean all plastic parts.  
**NOTE:** Certain cleaning chemicals can damage plastic parts.
6. Avoid use of cleaning chemicals or solvents, ammonia and household detergents containing ammonia.

### BLADE RAISING AND TILTING MECHANISM (FIG. ff, gg)

After every five hours of operation, the blade raising mechanism and tilting mechanism should be checked for looseness, binding, or any other abnormalities.

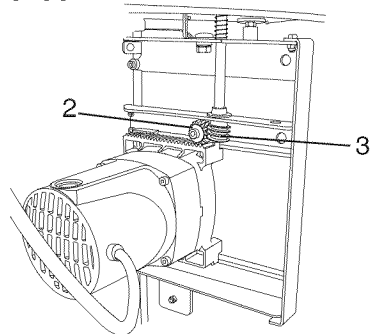
1. With the saw disconnected from the power source, turn the saw upside down and pull up and push down on the motor unit.
2. Observe any movement of the motor mounting mechanism.
3. Loosen or tighten the four hex screws (1) by hex wrench for smooth operation. Only 1/8 turn at a time.  
**NOTE:** Do not adjust the screw more than 1/2 turn as this may damage the mechanism.

Fig. ff



4. Place a small amount of dry lubricant on the bevel gear (2). The worm gear (3) must be kept clean and free of sawdust, gum, pitch, and other contaminants for smooth operations.

Fig. gg



# MAINTENANCE

**NOTE:** If excessive looseness is observed in any part of the blade raising mechanism or tilting mechanism, take the complete unit to a Service Center.

## LUBRICATION

All motor bearings are permanently lubricated at the factory and require no additional lubrication. On all mechanical parts of your table saw where a pivot or threaded rod are present, lubricate using graphite or silicone. These dry lubricants will not hold sawdust as would oil or grease.

## REPLACING THE CARBON BRUSHES (FIG. hh, ii)

### **WARNING**

**Always disconnect the plug from the power source before inspecting the brushes.**

The carbon brushes included with the unit will last approximately 50 hours of running time, or 10,000 ON/OFF cycles. Replace both carbon brushes when either has less than 1/4 in. length of carbon remaining, or if the spring or wire is damaged or burned.

1. Remove the blade guard, blade, rip fence, miter gauge and stand assembly from the table saw.
2. Lower the blade height to its minimum setting. This will make the brushes's location easier to access.
3. Place cardboard or an old blanket on the floor to protect the saw table surface.
4. Place the saw upside down on the protective material.
5. Tilt the blade elevation/tilting handwheel (1) to the 45° position.

6. Remove the black plastic cap (2) from the side of the motor (3).
7. Carefully remove the spring-loaded cap, and then pull out the brush and replace.
8. Replace the other side.
9. The ears on the metal end of the assembly go in the same hole the carbon part fits into. Do not overtighten the plastic cap.
10. Carefully set the saw in a upright position on a clean level surface.
11. Replace the blade guard, blade, rip fence, miter gauge and stand assembly to the table saw.

**NOTE:** To reinstall the same brushes, first make sure the brushes go back in the way they came out. This will avoid a break-in period that reduces motor performance and increases wear.

Fig. hh

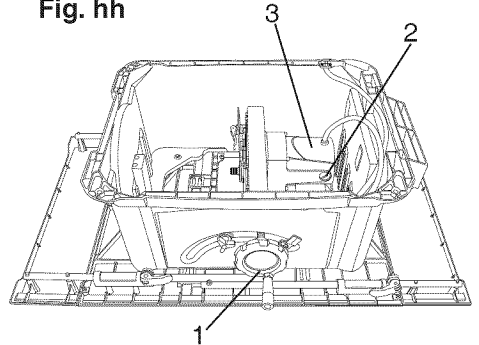
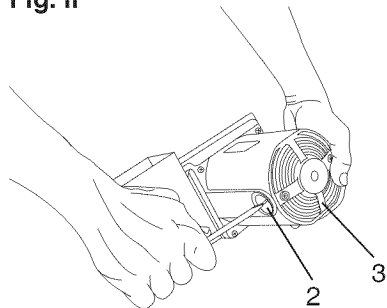


Fig. ii



# TROUBLESHOOTING GUIDE

## WARNING

To avoid injury from accidental starting, always turn switch OFF and unplug the tool before moving, replacing the blade or making adjustments.

PROBLEM	POSSIBLE CAUSES	CORRECTIVE ACTION
Saw will not start.	<ol style="list-style-type: none"> <li>1. Saw is not plugged in.</li> <li>2. Fuse blown or circuit breaker tripped.</li> <li>3. Cord is damaged.</li> <li>4. Debris in on/off switch</li> </ol>	<ol style="list-style-type: none"> <li>1. Plug in saw.</li> <li>2. Replace fuse or reset circuit breaker.</li> <li>3. Replace power cord.</li> <li>4. Remove switch from saw and separate in half. Clean any debris accumulated within.</li> </ol>
Does not make accurate 45° and 90° rip cuts.	<ol style="list-style-type: none"> <li>1. Positive stop not adjusted correctly.</li> <li>2. Tilt angle pointer not set accurately.</li> </ol>	<ol style="list-style-type: none"> <li>1. Check blade with square and adjust positive stop.</li> <li>2. Check blade with square and adjust to zero.</li> </ol>
Material pinched blade when ripping.	<ol style="list-style-type: none"> <li>1. Rip fence not aligned with blade.</li> <li>2. Warped wood, edge against fence is not straight.</li> </ol>	<ol style="list-style-type: none"> <li>1. Check and adjust rip fence.</li> <li>2. Select another piece of wood.</li> </ol>
Material binds on riving knife.	<ol style="list-style-type: none"> <li>1. Riving knife not aligned correctly with blade.</li> </ol>	<ol style="list-style-type: none"> <li>1. Check and align riving knife with blade.</li> </ol>
Saw makes unsatisfactory cuts.	<ol style="list-style-type: none"> <li>1. Dull blade.</li> <li>2. Blade mounted backwards.</li> <li>3. Gum or pitch on blade.</li> <li>4. Incorrect blade for work being done.</li> <li>5. Gum or pitch on blade causing erratic feed.</li> </ol>	<ol style="list-style-type: none"> <li>1. Replace blade.</li> <li>2. Turn the blade around.</li> <li>3. Remove blade and clean with turpentine and coarse steel wool.</li> <li>4. Change the blade.</li> <li>5. Clean table with turpentine and steel wool.</li> </ol>

# TROUBLESHOOTING GUIDE

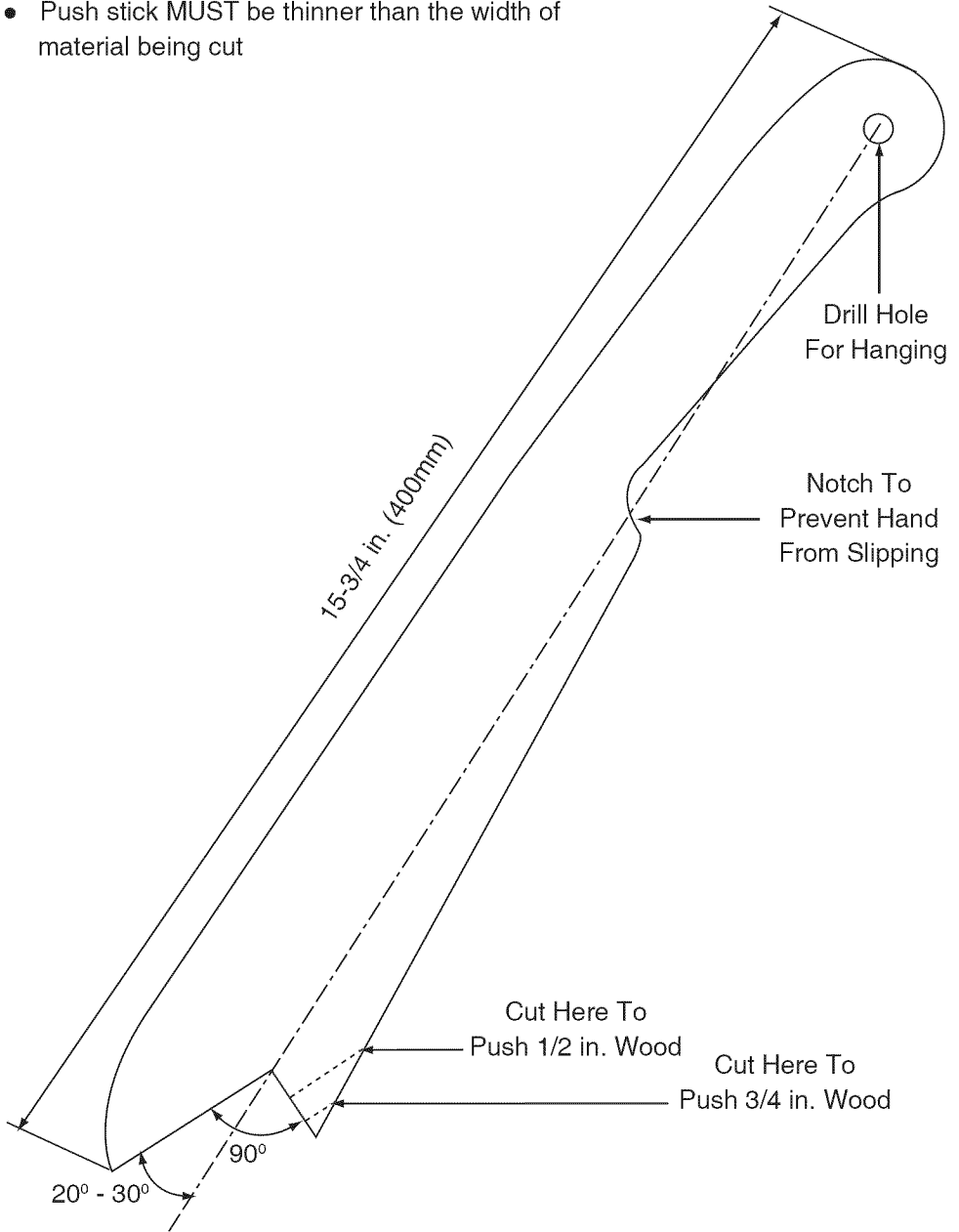
## WARNING

To avoid injury from accidental starting, always turn switch OFF and unplug the tool before moving, replacing the blade or making adjustments.

Material kicked back from blade.	<ol style="list-style-type: none"> <li>1. Rip fence out of adjustment.</li> <li>2. Riving knife not aligned with blade.</li> <li>3. Feeding stock without rip fence.</li> <li>4. Riving knife not in place.</li> <li>5. Dull blade.</li> <li>6. The operator letting go of material before it is past saw blade.</li> <li>7. Miter angle lock knob is not tight.</li> </ol>	<ol style="list-style-type: none"> <li>1. Align rip fence with miter gauge slot.</li> <li>2. Align riving knife with blade.</li> <li>3. Install and use rip fence.</li> <li>4. Install and use riving knife. (with guard)</li> <li>5. Replace blade.</li> <li>6. Push material all the way past saw blade before releasing work.</li> <li>7. Tighten knob.</li> </ol>
Blade does not raise or tilt freely.	<ol style="list-style-type: none"> <li>1. Sawdust and dirt in elevation/tilting mechanisms.</li> </ol>	<ol style="list-style-type: none"> <li>1. Brush or blow out loose dust and dirt.</li> </ol>
Blade does not come up to speed. Reset trips too easily.	<ol style="list-style-type: none"> <li>1. Extension cord too light or too long.</li> <li>2. Low house voltage.</li> </ol>	<ol style="list-style-type: none"> <li>1. Replace with adequate size cord.</li> <li>2. Contact your electric company.</li> </ol>
Machine vibrates excessively.	<ol style="list-style-type: none"> <li>1. Saw not mounted securely to workbench.</li> <li>2. Bench on uneven floor.</li> <li>3. Damaged saw blade.</li> </ol>	<ol style="list-style-type: none"> <li>1. Tighten all mounting hardware.</li> <li>2. Reposition on flat level surface.</li> <li>3. Replace blade.</li> </ol>
Does not make accurate 45° and 90° crosscuts.	<ol style="list-style-type: none"> <li>1. Miter gauge out of adjustment.</li> </ol>	<ol style="list-style-type: none"> <li>1. Adjust miter gauge.</li> </ol>

## PUSH STICK CONSTRUCTION

- Use good quality plywood or solid wood
- Use 1/2 in. or 3/4 in. material
- Push stick MUST be thinner than the width of material being cut



# PARTS LIST

10 in. TABLE SAW

MODEL NO. 137.218070



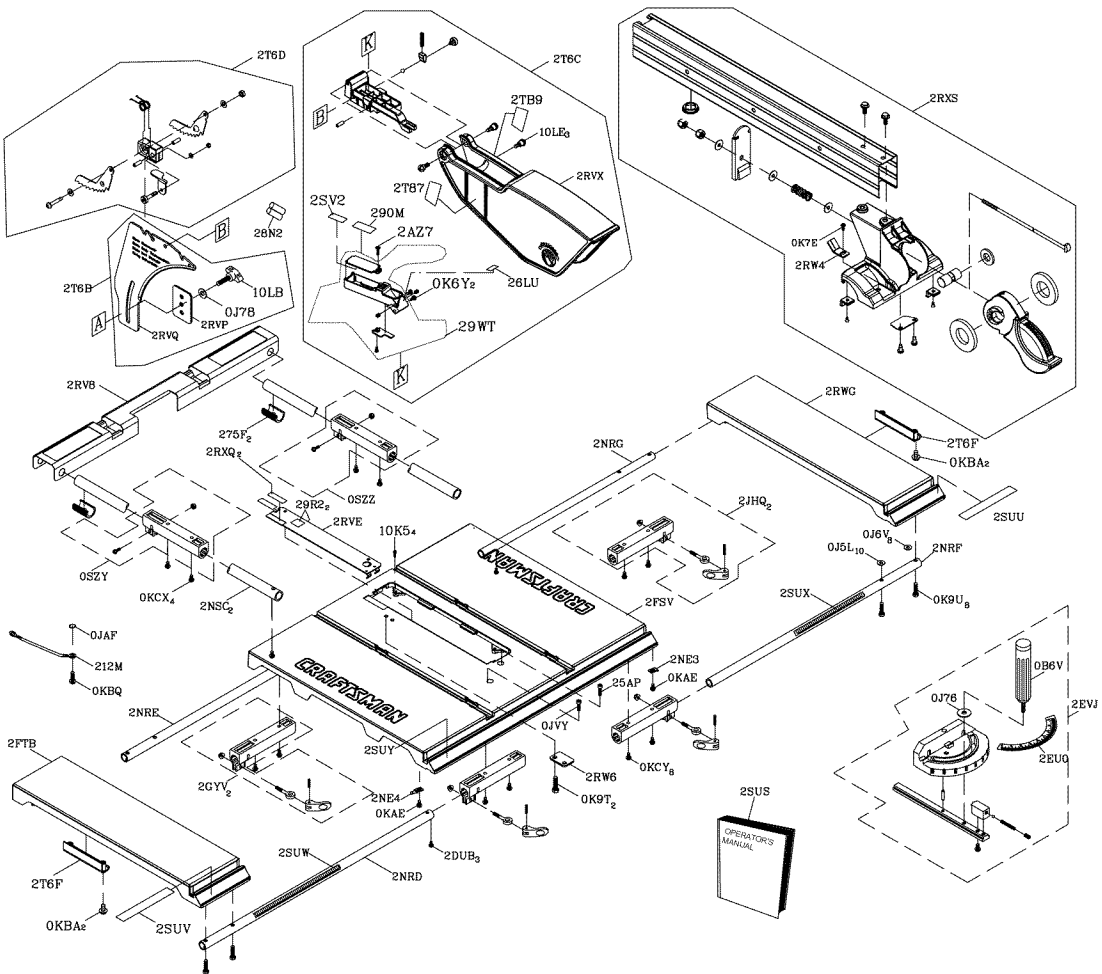
## WARNING

When servicing use only CRAFTSMAN replacement parts. Use of any other parts may create a HAZARD or cause product damage. Any attempt to repair or replace electrical parts on this Table Saw may create a HAZARD unless repair is done by a qualified service technician. Repair service is available at your nearest Sears Service Center.

### PARTS LIST FOR TABLE SAW SCHEMATIC A

I.D.	Description	Size	QTY	I.D.	Description	Size	QTY
0B6V	CLAMP HANDLE	M6*1.0	1	2FTB	EXTENSION WING (LEFT)	#AW	1
0J5L	FLAT WASHER	φ5*10-0.3	10	2GYV	SLIDING BASE ASS'Y		2
0J6V	FLAT WASHER	3/16*3/8-0.022	8	2JHQ	SLIDING BASE ASS'Y		2
0J76	FLAT WASHER	1/4*3/4-1/16	2	2NE3	NEEDLE POINTER		1
0J78	FLAT WASHER	1/4*1/2-3/32	1	2NE4	NEEDLE POINTER		1
0JAF	EXTERNAL TOOTH LOCK WASHER	φ5	1	2NRD	EXTENSION WING ROD		1
0JVY	HEX. SOC. HD. CAP BOLT	M6*1.0-16	1	2NRE	EXTENSION WING ROD		1
0K6Y	CR. RE. TRUSS HD. SCREW	M4*0.7-10	2	2NRF	EXTENSION WING ROD		1
0K7E	CR. RE. ROUND WASHER HD. SCREW	M5*0.8-6	1	2NRG	EXTENSION WING ROD		1
0K9T	HEX. HD. TAPPING SCREW	M5*16-16	2	2NSC	REAR OUT-FEED SUPPORT ROD		2
0K9U	HEX. HD. TAPPING SCREW	M5*16-25	8	2RV8	REAR OUT-FEED SUPPORT		1
0KAE	CR. RE. PAN HD. TAPPING SCREW	M5*0.8-10	3	2RVE	INSERT	#23	1
0KBA	CR. RE. PAN HD. TAPPING SCREW	M5*16-12	4	2RVP	SET PLATE		1
0KBQ	CR. RE. PAN HD. TAPPING SCREW	M5*16-10	1	2RVQ	RIVING KNIFE		1
0KCX	CR. RE. PAN HD PLAIN WASHER TAPPING SCREW	M5*0.8-10	4	2RVX	BLADE GUARD		1
0KCY	CR. RE. PAN HD PLAIN WASHER TAPPING SCREW	M5*0.8-12	8	2RW4	NEEDLE POINTER		1
0SZY	SLIDING BASE ASS'Y		1	2RW6	SET PLATE		1
0SZZ	SLIDING BASE ASS'Y		1	2RWG	EXTENTION WING (RIGHT)	#AW	1
10K5	HEX. SOC. HD. CAP BOLT	M5*0.8-8	4	2RXQ	SPACER		2
10LB	BOLT CLAMP		1	2RXS	RIP FENCE ASS'Y		1
10LE	CR. RE. TRUSS HD. ROUND NECK SCREW	M5*0.8-16	3	2SUU	SCALE(RIGHT)		1
212M	LEAD WIRE ASS'Y		1	2SUV	SCALE(LEFT)		1
25AP	HEX. SOC. HD. CAP BOLT	M6*1.0-25	1	2SUW	SCALE(LEFT)		1
26LU	WARNING LABEL		1	2SUX	SCALE(RIGHT)		1
275F	LOCATION SEAT		2	2SUY	SCALE		1
28N2	AAA BATTERY		2	2SV2	WARNING LABEL		1
290M	CAUTION LABEL		1	2SUS	INSTRUCTIONS MANUAL		1
29R2	WARNING LABEL		2	2T6B	HARDWARE BAG ASS'Y		1
29WT	LASER SET ASS'Y		1	2T6C	BLADE GUARD ASS'Y		1
2A27	CR. RE PAN HD PLAIN WASHER TAPPING SCREW	M2.6*24-8	1	2T6D	ANTI-KICKBACK PAWL ASS'Y		1
2DUB	CR. RE. ROUND WASHER HD. SCREW	M5*0.8-12	3	2T6F	HANDLE		2
2EU0	TILTING SCALE		2	2T87	LABEL(LASER)-LEFT		1
2EVJ	MITER GAUGE ASS'Y		1	2TB9	LABEL(LASER)-RIGHT		1
2FSV	TABLE	#AW	1				

10 in. TABLE SAW  
SCHEMATIC A

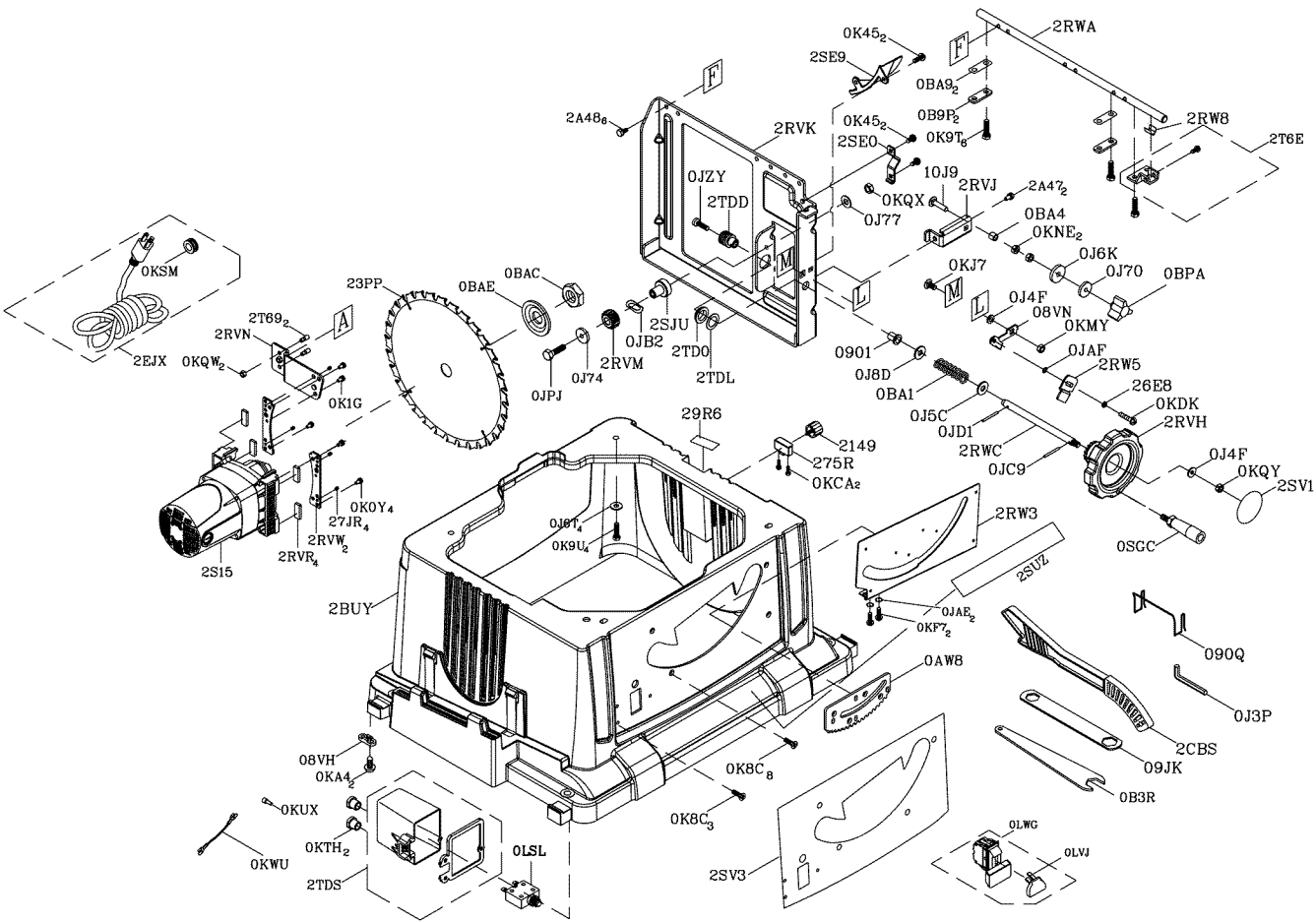


MODEL NO. 137.218070



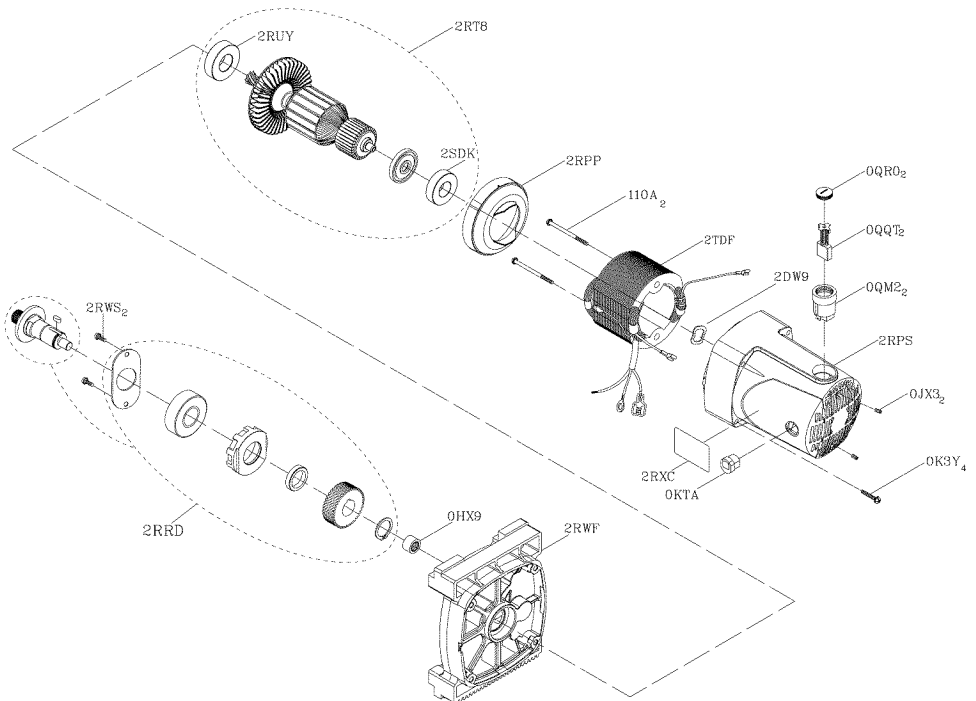
## PARTS LIST FOR SAW SCHEMATIC B

I.D.	Description	Size	QTY	I.D.	Description	Size	QTY
0901	BUSH		1	OKSM	STRAIN RELIEF		1
08VH	CORD CLAMP		1	OKTH	STRAIN RELIEF		2
08VN	POINTER BRACKET		1	OKUX	TERMINAL		1
090Q	PLUNGER HOUSING		1	OKWU	LEAD WIRE ASS'Y		1
09JK	WRENCH		1	OLSL	CIRCUIT BREAKER SWITCH		1
0AW8	SEGMENT GEAR		1	OLVJ	SWITCH KEY		1
0B3R	WRENCH		1	OLWG	ON/OFF ROCKER SWITCH ASSEMBLY		1
0B9P	CLAMP		2	OSGC	HANDLE BAR		1
0BA1	COMPRESSION SPRING		1	10J9	CAP HD. SQ. NECK BOLT	M6*1.0-40	1
0BA4	SPACER		1	2149	KNOB		1
0BA9	SPACER		2	23PP	BLADE		1
0BAC	SET NUT		1	26E8	FLAT WASHER	φ5*9.5-1.2	1
0BAE	ARBOR COLLAR		1	275R	LOCATION SEAT		1
0BPA	LOCK KNOB		1	27JR	HEX. SOC. SET SCREW	M5*0.8-6	4
0J3P	HEX. WRENCH		1	29R6	STICKER		1
0J4F	FLAT WASHER	φ8*16-2.5	2	2A47	HEX. HD. SCREW AND WASHER	M6*1.0-12	2
0J5C	FLAT WASHER	φ13.8*10-2.85	1	2A48	HEX. HD. SCREW AND WASHER	M5*0.8-16	6
0J6K	FLAT WASHER	φ6*30-4	1	2BUY	BODY SHELL		1
0J6T	FLAT WASHER	3/16*3/4-1/16	4	2CBS	PUSH BLOCK		1
0J70	FLAT WASHER	1/4*3/4-7/64	1	2EJX	POWER CABLE ASS'Y		1
0J74	FLAT WASHER	1/4*5/8-3/32	1	2RVH	WHEEL		1
0J77	FLAT WASHER	1/4*9/16-3/64	1	2RVJ	CLAMPER BRACKET		1
0J8D	FLAT WASHER	3/8*3/4-5/64	1	2RVK	BODY		1
0JAE	EXTERNAL TOOTH LOCK WASHER	φ4	2	2RVM	GEAR		1
0JAF	EXTERNAL TOOTH LOCK WASHER	φ5	1	2RVN	SPLITTER BRACKET		1
0JB2	WAVE WASHER	WW-12	1	2RVR	GUIDE CLAMP		4
0JC9	SPRING PIN		1	2RVW	RETAINING CLIP		2
0JD1	SPRING PIN		1	2RW3	RETAINING CLIP		1
0JPJ	HEX. HD. BOLT	M6*1.0-40	1	2RW5	NEEDLE POINTER		1
0JZY	HEX. SOC. TRUSS HD. SCREW	M6*1.0-12	1	2RW8	SHIM		1
OK0Y	HEX. HD. SCREW AND WASHER	M6*1.0-20	4	2RWA	ANGLE ROD		1
OK1G	HEX. HD. SCREW AND WASHER	M6*1.0-12	1	2RWC	HEIGHT REGULATING BOLT		1
OK45	CR. RE. PAN HD. SCREW & WASHER	M6*1.0-12	4	2S15	MOTOR ASS'Y		1
OK8C	CR. RE. COUNT HD. TAPPING SCREW	M4*18-10	11	2SE0	ANCHOR PLATE		1
OK9T	HEX. HD. TAPPING SCREW	M5*16-16	6	2SE9	SAFETY PLATE		1
OK9U	HEX. HD. TAPPING SCREW	M5*16-25	4	2SJU	SPACER		1
OKA4	CR. RE. PAN HD. TAPPING SCREW	M4*16-16	2	2SUZ	WARNING LABEL		1
OKCA	CR. RE. TRUSS HD. TAPPING SCREW	M5*12-12	2	2SV1	LABEL		1
OKDK	CR. RE. PAN HD. SCREW	M5*0.8-16	1	2SV3	LABEL		1
OKF7	CR. RE. PAN HD. SCREW	M4*0.7-12	2	2T69	SPECIAL BOLT		2
OKJ7	CAP HD. SQ. NECK BOLT	M8*1.25-16	1	2T6E	CLAMP ASS'Y		1
OKMY	HEX. NUT	M8*1.25 T=6.5	1	2TDD	COLLAR		1
OKNE	HEX. NUT	M6*1.0 T=5	2	2TDD	WORM		1
OKQW	LOCK NUT	M5*0.8 T=5	2	2TDL	FLAT WASHER		1
OKQX	NUT	M6*1.0 T=6	1	2TDS	SWITCH BOX ASS'Y		1
OKQY	LOCK NUT	M8*1.25 T=8	1				



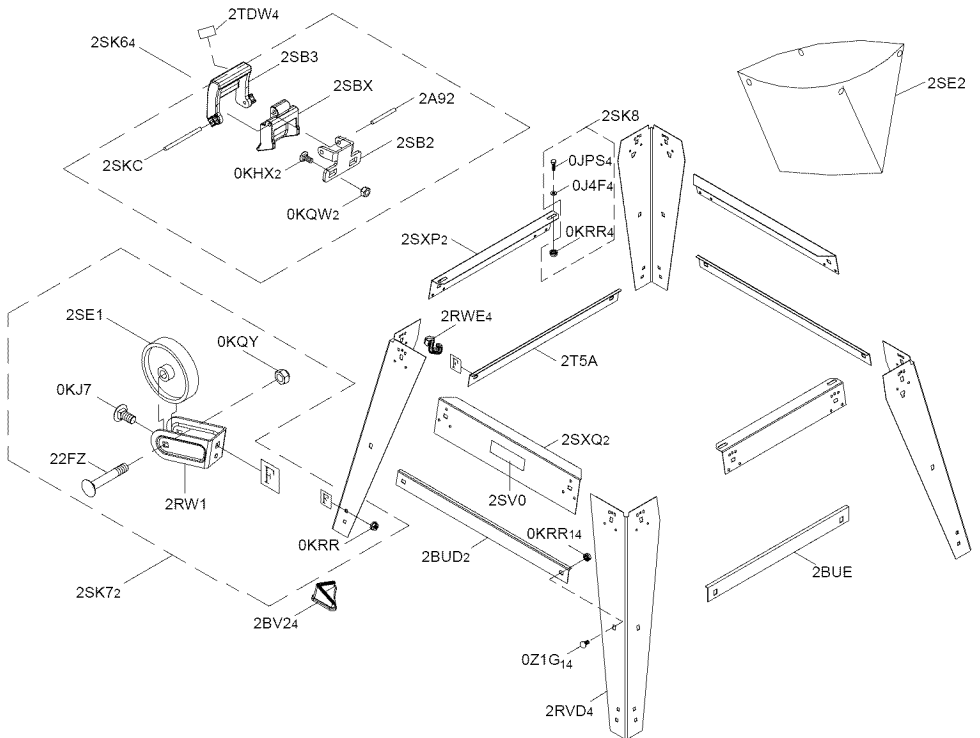
PARTS LIST FOR MOTOR

I.D.	Description	Size	QTY
0HX9	NEEDLE BEARING		1
0JX3	HEX. SOC. SET SCREW	M5*0.8-8	2
0K3Y	CR. RE. PAN HD. SCREW & WASHER	M5*0.8-50	4
0KTA	STRAIN RELIEF		1
0QM2	BRUSH HOLDER ASS'Y	Φ27*26.5	2
0QQT	BRUSH ASS'Y		2
0QR0	BRUSH COVER		2
110A	CR. RE. PAN HD. TAPPING SCREW & WASHER	M5*12-55	2
2DW9	WAVE WASHER		1
2RPP	FLOW GUIDE		1
2RPS	MOTOR COVER		1
2RRD	CUTTER SHAFT ASS'Y		1
2RT8	ARMATURE ASS'Y		1
2RUY	BALL BEARING	6002ZLU	1
2RWF	BRACKET		1
2RWS	CR. RE. COUNTER-SUNK HEAD SCREW	M5*0.8-10	2
2RXC	LABEL		1
2SDK	BALL BEARING	608ZZ	1
2TDF	FIELD ASS'Y		1



PARTS LIST FOR STAND

I.D.	Description	Size	QTY	I.D.	Description	Size	QTY
0J4F	FLAT WASHER	φ8*16-2.5	4	2SB2	PLUNGER HOUSING		1
0JPS	HEX. HD. BOLT	M8*1.25-45	4	2SB3	CLAMP HANDLE		1
0KJ7	CAP HD. SQ. NECK BOLT	M8*1.25-16	1	2SBX	HANDLE		1
0KHX	CAP HD. SQ. NECK BOLT	M5*0.8-10	2	2SE1	ROLLING WHEEL		1
0KQW	LOCK NUT	M5*0.8 T=5	2	2SE2	DUST BAG		1
0KQY	LOCK NUT	M8*1.25 T=8	1	2SK6	LOCKING HANDLE ASS'Y		4
0KRR	SERRATED TOOTHED HEXAGON FLANGE NUT	M8*1.25 T=7.5	19	2SK7	ROLLING WHEEL ASS'Y		2
0Z1G	CAP HD. SQ. NECK BOLT	M8*1.25-12	14	2SK8	HARDWARE BAG ASS'Y		1
22FZ	CAP HD. SQ. NECK BOLT	M8*1.25-45	1	2SK9	STAND ASS'Y		1
2A92	SPRING PIN		1	2SKC	SPRING PIN		1
2BUD	BOTTOM SUPPORT BRACKET	# AW	2	2SV0	TRADE-MARK LABEL		1
2BUE	BOTTOM SUPPORT BRACKET	# AW	1	2SXP	UPPER SUPPORT	# AW	2
2BV2	CUSHION		4	2SXQ	UPPER SUPPORT	# AW	2
2RVD	MAIN LEG BRACKET	# AW	4	2T5A	BOTTOM SUPPORT BRACKET	# AW	1
2RW1	BRACKET	# AW	1	2TDW	CAUTION LABEL		4
2RWE	DUST BAG HOOK		4				



# NOTE

# NOTE

# Get it fixed, at your home or ours!

## Your Home

For expert troubleshooting and home solutions advice:

**manage my home**

[www.managemyhome.com](http://www.managemyhome.com)

For repair – **in your home** – of **all** major brand appliances, lawn and garden equipment, or heating and cooling systems, **no matter who made it, no matter who sold it!**

For the replacement parts, accessories and owner's manuals that you need to do-it-yourself.

For Sears professional installation of home appliances and items like garage door openers and water heaters.

**1-800-4-MY-HOME®** (1-800-469-4663)

Call anytime, day or night (U.S.A. and Canada)

[www.sears.com](http://www.sears.com) [www.sears.ca](http://www.sears.ca)

## Our Home

For repair of carry-in items like vacuums, lawn equipment, and electronics, call anytime for the location of your nearest

**Sears Parts & Repair Service Center**

**1-800-488-1222** (U.S.A.)

[www.sears.com](http://www.sears.com)

**1-800-469-4663** (Canada)

[www.sears.ca](http://www.sears.ca)

To purchase a protection agreement on a product serviced by Sears:

**1-800-827-6655** (U.S.A.)

**1-800-361-6665** (Canada)

Para pedir servicio de reparación a domicilio, y para ordenar piezas:

**1-888-SU-HOGAR®**

(1-888-784-6427)

Au Canada pour service en français:

**1-800-LE-FOYER<sup>MC</sup>**

(1-800-533-6937)

[www.sears.ca](http://www.sears.ca)

**Sears**

© Registered Trademark / <sup>TM</sup> Trademark / <sup>SM</sup> Service Mark of Sears Brands, LLC

© Marca Registrada / <sup>TM</sup> Marca de Fábrica / <sup>SM</sup> Marca de Servicio de Sears Brands, LLC

<sup>MC</sup> Marque de commerce / <sup>MD</sup> Marque déposée de Sears Brands, LLC

© Sears Brands, LLC