

DUCTLESS MINI SPLIT SYSTEM AIR CONDITIONER / HEAT PUMP

PIONEER®

CYK-24 Inverter Series

For 9,000-18,000 BTU/hr Systems

Quantum Ultra (R-454B) - CK Indoor and YN Outdoor

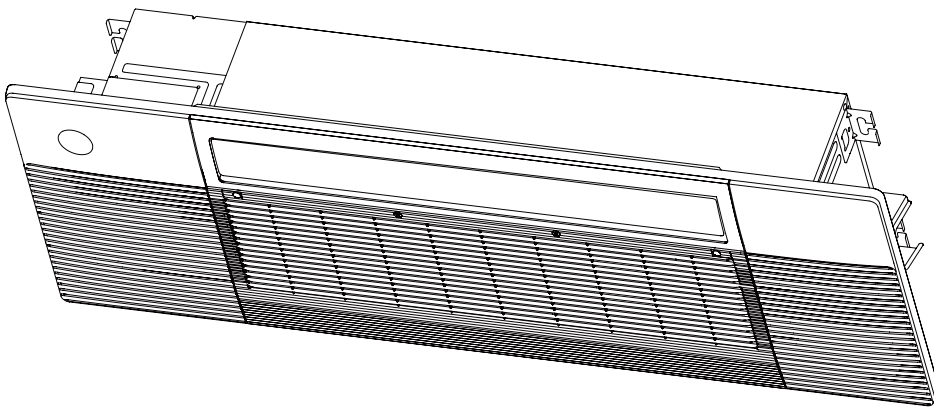

Installation & User Manual

IMPORTANT NOTICE:

Read this manual carefully before installing or operating your new air conditioning system. Be sure to save this manual for future reference.



REV250521

Table of Contents

1	Safety Precautions.....	2
2	Product Overview.....	17
3	Product Installation.....	19
4	Indoor Unit Installation.....	20
	5 Outdoor Unit Installation.....	27
	6 Refrigerant Piping Connection.....	34
	7 Wiring Precautions.....	38
	8 Air Evacuation.....	42
	9 Note on Adding Refrigerant.....	44
10	Electrical & Gas Leak Checks.....	45
11	Panel Installation.....	46
12	Test Run.....	53
13	Unpacking & Packing.....	55
14	Operation Instructions.....	56
15	Care & Maintenance.....	59
T	Troubleshooting.....	63

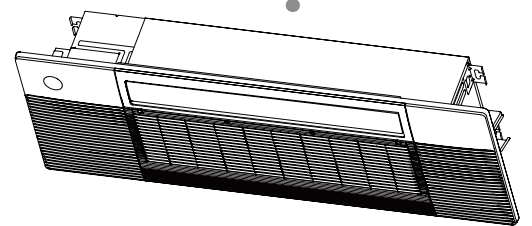
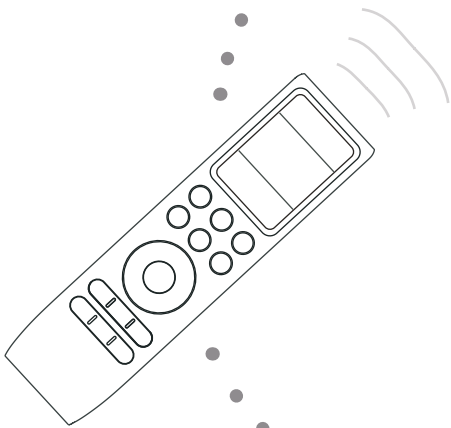
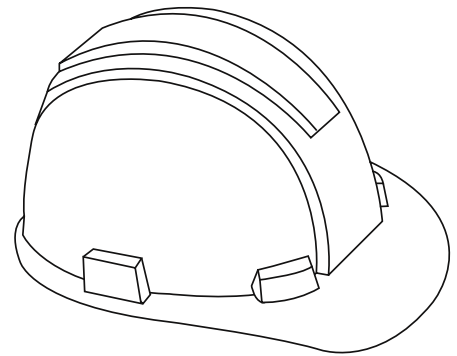

Read this Manual

The manual provides helpful hints on using and maintaining the air conditioner properly. Performing preventive care can save time and money over the lifespan of the air conditioner. These instructions may not cover every possible condition of use, so common sense and attention to safety is required when installing, operating, and maintaining this product.

Safety Precautions

1

It is important to read this section before operating and installing the system. Incorrect installation due to ignoring instructions can cause serious damage or injury. The seriousness of potential damage and injuries is classified as either a warning or caution.

Explanation of Symbols



WARNING

This symbol indicates the possibility of personal injury or loss of life.



CAUTION

This symbol indicates the possibility of property damage or serious consequences.



WARNING

Children aged 8 and above, as well as individuals with lack of experience or reduced physical, sensory, or mental capabilities can use the appliance if supervision or instruction is given. Do not allow children to play with or near the appliance. Children or untrained personnel should be restricted from cleaning and performing maintenance on the appliance, unless they're given supervision.



WARNINGS FOR PRODUCT USE

- Turn off the air conditioner and disconnect the power before cleaning, installing, or repairing the system. Failure to do so can cause electric shock.
- If an abnormal situation arises (such as a burning smell), immediately turn off the unit and disconnect the power. Call the dealer for instructions to avoid electrical shock, fire, or injury.
- Do not insert fingers, rods, or other objects into the air inlet or outlet. This could cause injury because the fan rotates at high speeds.
- Do not use flammable sprays such as hair spray, lacquer, or paint near the unit. This may cause fire or combustion.
- Do not operate the air conditioner in locations near or around combustible gases. Emitted gas may collect around the unit and cause an explosion.
- Do not operate the air conditioner in a wet room such as a bathroom or laundry room. Too much exposure to water can cause electrical components to short circuit.
- Do not expose your body directly to cool air for prolonged durations of time.
- If the air conditioner is used together with burners or other heating devices, thoroughly ventilate the room to avoid oxygen deficiency.
- In certain functional environments (such as kitchens, server rooms, etc.), it is highly recommended to use specifically designed air-conditioning units.

Safety Precautions

1

WARNINGS FOR PRODUCT INSTALLATION

- Turn off the air conditioner and disconnect its power supply before installing or repairing the system. Failure to do so can cause electric shock.
- An authorized dealer or specialist must perform the installation. Incorrect installation can cause water leakage, electrical shock, or fire.
- Perform the installation according to the instructions in this manual. Improper installation can cause water leakage, electrical shock, or fire.
- Contact an authorized service technician to maintain and repair the unit.
- Install the appliance in accordance with national wiring regulations. Only use the included accessories, parts, and specified parts for installation. Using non-standard parts can cause water leakage, electrical shock, fire, or unit failure.
- Install the unit in a firm location that can support the unit's weight. If the chosen location cannot support the unit's weight or the installation is done incorrectly, the unit may drop and cause serious injury or damage.
- For units with an auxiliary electric heater, do not install the unit within 3 feet (1 m) of any combustible materials.
- For units that have a wireless network function (USB device access replacement), professional staff must carry out the maintenance operations.
- Do not install the unit in a location that may be exposed to combustible gas leaks. If combustible gas accumulates around the unit, it could cause fire.
- Do not turn on the power until all work has been completed.
- When moving or relocating the air conditioner, consult experienced service technicians for the disconnection and reinstallation of the unit.
- For information on installing the appliance to its support, read the Indoor Unit Installation and Outdoor Unit Installation sections.

ELECTRICAL WARNINGS

- Only use the specified wire. If the wire is damaged, it must be replaced by the manufacturer, service agent, or a similarly qualified individual in order to avoid a hazard.
- Properly ground the product during installation to avoid electrical shock.
- Incorporate disconnection in the fixed wiring, according to the wiring rules.
- Do not share the electrical outlet with other appliances. Improper or insufficient power supply can cause fire or electric shock.

Safety Precautions

1

- For all electrical work, follow the local and national wiring standards, regulations, and installation manual. Connect the cables tightly, then clamp them securely to prevent external forces from damaging the terminal. Improper electrical connections can result in electrical shock or fire. Complete the electrical connections according to the Electrical Connection diagram located on the panels of the indoor and outdoor units.
- Properly arrange all wiring to ensure that the control board cover can close correctly. If the control board cover is not closed properly, it can lead to corrosion and cause the connection points on the terminal to heat up and catch fire. It can also cause electrical shock.
- If connecting power to fixed wiring, incorporate an all-pole disconnection device in the fixed wiring. Ensure that the device is in accordance with the wiring rules.

CLEANING & MAINTENANCE WARNINGS

- Turn off the device and disconnect its power supply before cleaning. Failure to do so can cause an electrical shock.
- Do not clean the air conditioner with excessive amounts of water.
- Do not clean the air conditioner with combustible cleaning agents. Combustible cleaning agents can cause fire or deformation.

CAUTION

- Turn off the air conditioner and disconnect the power if the unit will not be used for a long duration of time.
- Turn off and unplug the unit during storms.
- Make sure that water condensation can drain unhindered from the unit.
- Do not operate the air conditioner with wet hands. This may cause electrical shock.
- Do not use the device for any other purpose than its intended use.
- Do not climb onto or place objects on top of the outdoor unit.
- Do not allow the air conditioner to operate for long periods of time with doors or windows open, or if the humidity is considerably high.

TAKE NOTE OF FUSE SPECIFICATIONS

The air conditioner's circuit board (PCB) is designed with a fuse to provide overcurrent protection. The specifications of the fuse are printed on the circuit board. For example: T3.15AL/250VAC, T5AL/250VAC, T3.15A/250VAC, T5A/250VAC, T20A/250VAC, T30A/250VAC, etc.

Note: Only use the blast-proof ceramic fuse.

Safety Precautions

1

⚠ WARNING FOR USING FLAMMABLE REFRIGERANTS

- Do not use means to accelerate the defrosting and cleaning processes, other than those recommended by the manufacturer.
- Store the appliance in a room without continuously operating ignition sources. For example: open flames, an operating gas appliance, or an operating electric heater.
- Do not pierce or burn.
- Be aware that refrigerants may not contain an odor.

R-454B refrigerant charge amount and minimum room are

The machine you purchased may be one of the types listed in the table below. The indoor and outdoor units are designed to be used together. Check the machine that was purchased. Install the indoor unit at least 7.6 feet (2.3 m) above the floor. The height of the room cannot be less than the indoor unit's installed height. The minimum room area of operation or storage is as specified in the following table:

For the units with refrigerant sensors, when the unit detects a refrigerant leak, the minimum airflow of the indoor unit is as follows:

Model	Indoor Unit	Outdoor Unit	Indoor Nominal Air Volume	
9K	CK009GMSILDFHG	YN009GMSI24RPG	580m ³ /h	342CFM
12K	CK012GMSILDFHG	YN012GMSI24RPG	680m ³ /h	400CFM
18K	CK018GMSILDFHG	YN018GMSI24RPG	600m ³ /h	353CFM

The information in the following table is only applicable to models without refrigerant sensors:

Model	Indoor Unit	Outdoor Unit
9K	CK009GMSILDFHG	YN009GMSI24RPG
12K	CK012GMSILDFHG	YN012GMSI24RPG
18K	CK018GMSILDFHG	YN018GMSI24RPG

Safety Precautions

1

A_{\min} [ft ² / m ²]	h_{inst} [ft/m]					
	m_c or m_{REL} [ozs/kg]	6.0~7.3/ 1.8~2.2	7.6/2.3	7.9/2.4	8.6/2.6	9.2/2.8
<=62.6/1.776	12/1.10					
63.4/1.8	60/5.53	57/5.29	55/5.07	51/4.68	47/4.35	44/4.06
70.5/2.0	67/6.15	64/5.88	61/5.64	56/5.20	52/4.83	49/4.51
77.5/2.2	73/6.76	70/6.47	67/6.20	62/5.72	58/5.31	54/4.96
84.6/2.4	80/7.38	76/7.06	73/6.76	68/6.24	63/5.80	59/5.41
91.7/2.6	86/7.99	83/7.64	79/7.32	73/6.76	68/6.28	64/5.86
98.7/2.8	93/8.60	89/8.23	85/7.89	79/7.28	73/6.76	68/6.31
105.8/3.0	100/9.22	95/8.82	91/8.45	84/7.80	78/7.24	73/6.76
112.8/3.2	106/9.83	102/9.41	97/9.01	90/8.32	84/7.73	78/7.21
119.9/3.4	113/10.45	108/9.99	104/9.58	96/8.84	89/8.21	83/7.66
126.9/3.6	120/11.06	114/10.58	110/10.14	101/9.36	94/8.69	88/8.11
134/3.8	126/11.68	121/11.17	116/10.70	107/9.88	99/9.17	93/8.56
141.0/4.0	133/12.29	127/11.76	122/11.27	112/10.40	104/9.66	97/9.01
148.1/4.2	139/12.90	133/12.34	128/11.83	118/10.92	110/10.14	102/9.46
155.1/4.4	146/13.52	140/12.93	134/12.39	124/11.44	115/10.62	107/9.91
162.2/4.6	153/14.13	146/13.52	140/12.96	129/11.96	120/11.11	112/10.37
169.2/4.8	159/14.75	152/14.11	146/13.52	135/12.48	125/11.59	117/10.82
176.3/5.0	166/15.36	159/14.69	152/14.08	140/13.00	130/12.07	122/11.27
Area formula	<ul style="list-style-type: none"> • A_{\min} is the required minimum room area in ft²/m². • M_c is the actual refrigerant charge in the system in oz/kg • M_{REL} is the refrigerant releasable charge in oz/kg (applicable to the units with refrigerant sensors only) • h_{inst} is the height of the bottom of the appliance relative to the floor of the room after installation. <p>WARNING: The minimum room area or minimum room of conditioner space is based on the releasable charge and total system refrigerant charge.</p>					

Safety Precautions

1

1. Installation

(Where refrigerant pipes are allowed)

- Any individual who is involved with working on or breaking into a refrigerant circuit must hold a valid certificate from an industry-accredited assessment authority. The certificate authorizes the individual's competence for handling refrigerants safely in accordance with the specifications of an industry recognized assessment.
- Maintenance and repairs requiring the assistance of other skilled personnel must be carried out under the supervision of the individual competent in the use of flammable refrigerants.
- Keep the installation of the pipe-work to a minimum.
- Protect the pipe-work from physical damage.
- Ensure that the refrigerant pipes comply with national gas regulations.
- Ensure that the mechanical connections are accessible for maintenance purposes.
- Do not allow foreign matter (oil, water, etc.) from entering the piping. In addition, when storing the piping, securely seal the opening by pinching, taping, etc.
- Competent individuals must carry out all working procedures that affect safety.
- Store the appliance in a well-ventilated area where the room size corresponds to the room area as specified for operation.
- Test the joints using detection equipment with a capability of 5g/year of refrigerant or better. After installation, ensure that the equipment is at a standstill and maintained under operating pressure, or at least the minimum standstill pressure.
- In cases that require mechanical ventilation, ensure that the ventilation openings are kept clear of obstruction.
- Leak Detection System Installed: Power the unit except for service.
For units with refrigerant sensors, when the sensor detects refrigerant leakage, the indoor unit will display an error code and emit a buzzing sound, the outdoor unit's compressor will immediately stop, and the indoor fan will start running. The service life of the refrigerant sensor is 15 years. When the refrigerant sensor malfunctions, the indoor unit will display the "FHCC" error code. The refrigerant sensor cannot be repaired and can only be replaced by the manufacturer. Replace the sensor with one specified by the manufacturer.
(Applicable to units with refrigerant sensors only.)

2. When a flammable refrigerant is used, the requirements for the installation space of the appliance and/or ventilation are determined according to the:

- Mass charge amount (M) used in the appliance.
- Installation location.
- Ventilation type of the location or appliance.
- Protect the piping material and pipe routing from physical damage during operation and service. Ensure that the piping material and pipe routing are in compliance with national and local codes and standards, such as ASHRAE 15, IAPMO Uniform Mechanical Code, ICC International Mechanical Code, or CSA B52. All field joints must be accessible for inspection prior to being covered or enclosed.
- Protect piping, fittings, and protection devices from adverse environmental effects. For example, water collecting and freezing in relief pipes or the accumulation of dirt and debris.

Safety Precautions

1

- Ensure that the piping in the refrigerant system is designed and installed to minimize the likelihood of hydraulic shock damaging the system.
- Before applying any insulation, protect the steel pipes and components against corrosion with a rustproof coating.
- Take precautions to avoid excessive vibration or pulsation.
- The minimum floor area of the room is mentioned in the form of a table or single figure without reference to a formula.
- After completing the field piping for split systems, pressure test the field pipework with an inert gas. Then, vacuum test the pipework before refrigerant charging. Ensure that the testing is completed according to the following requirements:
 - a. The minimum test pressure for the low side of the system must be the low side design pressure and the minimum test pressure for the high side of the system must be the high side design pressure, unless the high side of the system cannot be isolated from the low side of the system. If the high side cannot be isolated from the low side of the system, the entire system must be pressure tested to the low side design pressure.
 - b. After removing the pressure source, maintain the test pressure for at least 1 hour, ensuring that there is no decrease of pressure, which is indicated by the test gauge. Ensure that the test gauge resolution does not exceed 5% of the test pressure.
 - c. During the evacuation test, after achieving a vacuum level specified in the manual, isolate the refrigeration system from the vacuum pump and ensure that the pressure does not rise above 1,500 microns within 10 minutes. The appropriate vacuum pressure level is specified in the manual, and must not be less than 500 microns or the value required for compliance with national and local codes and standards. The codes and standards may vary between residential, commercial, and industrial buildings.
- Field-made refrigerant indoor joints must be tightness tested according to the following requirements: The test method must have a sensitivity of 5 grams per year of refrigerant or better under a pressure of at least 0.25 times the maximum allowable pressure. No leak should be detected.

3. Qualification of Workers

The working personnel must be qualified to perform any maintenance, service, and repair operations. Competent individuals must carry out working procedures that affect safety means. The competent individual must complete the training by national training organizations or manufacturers that are accredited to teach the relevant national competency standards set in legislation. The individual's competence must be documented by a certificate. All training must follow the ANNEX HH requirements of UL 60335-2-40 4th Edition.

Examples for such working procedures are:

- breaking into the refrigerating circuit.
- opening of sealed components.
- opening of ventilated enclosures.

4. Well-Ventilated Area

Before breaking into the system or conducting any hot work, ensure that the area is in the open or is adequately ventilated. Maintain a degree of ventilation while the work is being carried out. Ensure that the ventilation safely disperses any released refrigerant and preferably expels it externally into the atmosphere.

5. Cabling

Confirm that the cabling will not be subject to wear, corrosion, excessive pressure, vibration, sharp edges, or any other adverse environmental effects. The check should also take into account the effects of aging or continual vibration from sources such as compressors or fans.

Safety Precautions

1

6. Detection of Flammable Refrigerants

Do not use potential sources of ignition for searching or detecting refrigerant leaks. Do not use a halide torch or detector using a naked flame. Ensure that the detector is not a potential source of ignition and is suitable for the refrigerant used. Leak detection equipment must be set at a percentage of the refrigerant LFL, and calibrated to the refrigerant employed. Confirm the appropriate percentage of gas (25% maximum).

The following leak detection methods are deemed acceptable for refrigerant systems:

Electronic leak detectors: This type of detector can detect refrigerant leaks. However, in the case of flammable refrigerants, the sensitivity may not be adequate and need recalibration. Calibrate the detection equipment in a refrigerant-free area.

Leak detection fluids: The bubble method and fluorescent method agents are examples of leak detection fluids. These are suitable to use with most refrigerants. Avoid using detergents containing chlorine as the chlorine may react with the refrigerant and corrode the copper pipe-work.

If a leak is suspected, remove or extinguish all naked flames.

If a refrigerant leak is found and requires brazing, recover all the refrigerant from the system or use the shut off valves to isolate the refrigerant in a part of the system remote from the leak. See the following instructions for removing refrigerant.

7. Removal and Evacuation

Use conventional procedures when breaking into the refrigerant circuit to make repairs or for any other purpose. However, for flammable refrigerants, it is important to follow this best practice since flammability is a consideration.

Follow this procedure:

- Safely remove refrigerant following local and national regulations.
- Evacuate.
- Purge the circuit with inert gas (optional for A2L).
- Evacuate (optional for A2L).
- Continuously flush or purge with inert gas when using a flame to open the circuit.
- Open the circuit.

Recover the refrigerant charge into the correct recovery cylinders if venting is not allowed by local and national codes. For appliances containing flammable refrigerants, purge the system with oxygen-free nitrogen to render the appliance safe from flammable refrigerants. If needed, repeat this process several times. Do not use compressed air or oxygen to purge refrigerant systems.

For appliances containing flammable refrigerants, purge the refrigerant by breaking the vacuum in the system with oxygen-free nitrogen and continuing to fill until the working pressure is achieved. Then, vent to atmosphere and finally pull down to a vacuum (optional for A2L). Repeat this process until no refrigerant is present within the system (optional for A2L). When using oxygen-free nitrogen, vent the system down to atmospheric pressure to enable work to take place. Ensure that the outlet for the vacuum pump is not close to any potential ignition sources and ventilation is available.

Safety Precautions

1

8. Charging Procedures

In addition to conventional charging procedures, follow these requirements:

- Use only appropriate tools when completing work. In case of uncertainty, consult the manufacturer of the tools for information on use with flammable refrigerants.
- Ensure that the contamination of different refrigerants does not occur when using charging equipment. Hoses or lines must be as short as possible to minimize the amount of refrigerant contained in them.
- Keep the cylinders upright.
- Ensure that the refrigerant system is earthed before charging the system with refrigerant.
- Label the system when charging is complete (if not already).
- Take extreme care to not overfill the refrigeration system.
- Prior to recharging the system, it must be pressure tested with oxygen-free nitrogen. Leak test the system after completing the charging but prior to commissioning. Carry out a follow up leak test before leaving the site.

9. Recovery

When removing refrigerant from a system, either for servicing or decommissioning, it is recommended good practice to remove refrigerants safely. When transferring refrigerant into cylinders, ensure that only appropriate refrigerant recovery cylinders are employed. Ensure that the correct number of cylinders for holding the total system charge are available. Designate all the cylinders intended to be used.

Servicing Information

1. Inspect the Area

Before working on systems containing flammable refrigerants, safety checks are required to ensure that the risk of ignition is minimized. The following precautions must be complied with prior to conducting repairs on the system.

2. Work Procedure

To minimize the risk of flammable gas or vapor presence, conduct work using controlled procedures.

3. General Work Area

Inform all maintenance staff and individuals working in the local area about the nature of the work being performed. Avoid working in confined spaces. Section off the area around the workspace. Ensure that the area is safe by controlling flammable materials.

4. Check for Refrigerant

Check the area with an appropriate refrigerant detector before and during work to ensure that the technician is aware of potentially flammable atmospheres. Ensure that the leak detection equipment is suitable for flammable refrigerants, i.e. non-sparking, adequately sealed, or intrinsically safe.

5. Fire Extinguisher

If conducting hot work on the refrigeration equipment or any associated parts is needed, appropriate fire extinguishing equipment must be available. Keep a dry powder or CO₂ fire extinguisher adjacent to the charging area.

Safety Precautions

1

6. No Ignition Sources

Individuals carrying out work involving exposed pipework on a refrigerant system are prohibited from using any sources of ignition that may lead to a risk of fire or explosion. All possible ignition sources, such as cigarette smoking, must be performed at a sufficient distance from the installation or maintenance site. Before conducting work on the equipment, the surrounding area must be surveyed to ensure that there are no flammable hazards or ignition risks. No Smoking signs must be displayed.

7. Well-Ventilated Area

Ensure that the area is open and well-ventilated before accessing the system or performing any work that generates heat. Ventilation must be maintained to a certain degree while work is being carried out. The ventilation should safely disperse any released refrigerant and expel it externally into the atmosphere.

8. Inspect the Refrigeration Equipment

When changing electrical components, they must be fit-for-purpose and meet the correct specifications. Follow the manufacturer's maintenance and service guidelines at all times. If in doubt, consult the manufacturer's technical department for assistance.

For installations using flammable refrigerants, check the following:

- Ensure that the charge size is appropriate for the room in which the refrigerant-containing parts are installed.
- Confirm the ventilation machinery and outlets are operating adequately and not obstructed.
- If an indirect refrigerating circuit is being used, check the secondary circuit for the presence of refrigerant.
- Confirm the equipment markings are visible and legible. Correct markings and signs that are illegible.
- Install the refrigeration pipe or components in a position that minimizes the risk of corrosion from harmful substances, unless constructed of corrosion-resistant materials and suitably protected.

9. Inspect the Electrical Devices

Repairing and maintaining electrical components must include initial safety checks and component inspections. If a fault exists that could compromise safety, do not connect the electrical supply to the circuit until the fault is resolved. If the fault cannot be immediately corrected but it is necessary to continue operation, a temporary solution must be implemented. If a temporary solution is implemented, it must be reported to the owner of the equipment, ensuring both parties are informed.

Initial safety checks must include the following:

- Confirm the capacitors are discharged. Ensure that this is done in a safe manner to avoid the possibility of sparking.
- Ensure that no live electrical components and wiring are exposed while charging, recovering, or purging the system.
- Confirm there is continuity of earth bonding.

10. Replace Sealed Electrical Components If It's Damaged.

11. Replace Intrinsically Safe Components If It's Damaged.

12. Cabling

Confirm that the cabling will not be subject to wear, corrosion, excessive pressure, vibration, sharp edges, or any other adverse environmental effects. The check should also take into account the effects of aging or continual vibration from sources such as compressors or fans.

Safety Precautions

1

13. Detection of Flammable Refrigerants

Do not use potential sources of ignition for searching or detecting refrigerant leaks. Do not use a halide torch or detector using a naked flame. Ensure that the detector is not a potential source of ignition and is suitable for the refrigerant used. Leak detection equipment must be set at a percentage of the refrigerant LFL, and calibrated to the refrigerant employed. Confirm the appropriate percentage of gas (25% maximum).

The following leak detection methods are deemed acceptable for refrigerant systems:

Electronic leak detectors: This detector can detect refrigerant leaks. However, in the case of flammable refrigerants, the sensitivity may not be adequate and need recalibration. Calibrate the detection equipment in a refrigerant-free area.

Leak detection fluids: The bubble method and fluorescent method agents are examples of leak detection fluids. These are suitable to use with most refrigerants. Avoid using detergents containing chlorine as the chlorine may react with the refrigerant and corrode the copper pipe-work.

If a leak is suspected, remove or extinguish all naked flames.

If a refrigerant leak is found and requires brazing, recover all the refrigerant from the system or use the shut off valves to isolate the refrigerant in a part of the system remote from the leak. See the following instructions for removing refrigerant.

14. Removal and Evacuation

Use conventional procedures when breaking into the refrigerant circuit to make repairs or for any other purpose. However, for flammable refrigerants, it is important to follow this best practice since flammability is a consideration.

Follow this procedure:

- Safely remove refrigerant following local and national regulations.
- Evacuate.
- Purge the circuit with inert gas (optional for A2L).
- Evacuate (optional for A2L).
- Continuously flush or purge with inert gas when using a flame to open the circuit.
- Open the circuit.

Recover the refrigerant charge into the correct recovery cylinders if venting is not allowed by local and national codes. For appliances containing flammable refrigerants, purge the system with oxygen-free nitrogen to render the appliance safe from flammable refrigerants. If needed, repeat this process several times. Do not use compressed air or oxygen to purge refrigerant systems.

For appliances containing flammable refrigerants, purge the refrigerant by breaking the vacuum in the system with oxygen-free nitrogen and continuing to fill until the working pressure is achieved. Then, vent to atmosphere and finally pull down to a vacuum (optional for A2L). Repeat this process until no refrigerant is within the system (optional for A2L). When using oxygen-free nitrogen, vent the system down to atmospheric pressure to enable work to take place. Ensure that the outlet for the vacuum pump is not close to any potential ignition sources and ventilation is available.

Safety Precautions

1

15. Charging Procedures

In addition to conventional charging procedures, follow these requirements:

- Use only appropriate tools when completing work. In case of uncertainty, consult the manufacturer of the tools for use with flammable refrigerants.
- Ensure that the contamination of different refrigerants does not occur when using charging equipment. Hoses or lines must be as short as possible to minimize the amount of refrigerant contained in them.
- Keep the cylinders upright.
- Ensure that the refrigerant system is earthed before charging the system with refrigerant.
- Label the system when charging is complete (if not already).
- Take extreme care to not overfill the refrigeration system.
- Prior to recharging the system, it must be pressure tested with oxygen-free nitrogen. Leak test the system after completing the charging but prior to commissioning. Carry out a follow up leak test before leaving the site.

16. Decommissioning

Before carrying out this procedure, it is essential that the technician is completely familiar with the equipment and all its details. It is recommended good practice that all refrigerants are recovered safely. Prior to carrying out the task, take an oil and refrigerant sample in case an analysis is required prior to re-using the recovered refrigerant. It is essential that electrical power is available before the task is commenced.

- a) Become familiar with the equipment and its operations.
- b) Isolate the system electrically.
- c) Before attempting the procedure ensure that
 - Mechanical handling equipment is available for handling refrigerant cylinders.
 - All personal protective equipment is available and being used correctly.
 - A competent individual is supervising the recovery process at all times.
 - Recovery equipment and cylinders conform to the appropriate standards.
- d) Pump down the refrigerant system, if possible.
- e) If a vacuum is not possible, make a manifold so that the refrigerant can be removed from various parts of the system.
- f) Make sure that the cylinder is situated on the scales before recovery takes place.
- g) Start the recovery machine and operate it in accordance with the instructions.
- h) Do not overfill cylinders (no more than 80% volume liquid charge).
- i) Do not exceed the maximum working pressure of the cylinder, even temporarily.
- j) When the cylinders have been filled correctly and the process is completed, make sure that the cylinders and equipment are removed from the site promptly and all isolation valves on the equipment are closed off.
- k) Do not charge recovered refrigerant into another refrigeration system, unless it has been cleaned and checked.

Safety Precautions

1

17. Labeling

Label the equipment stating that it has been de-commissioned and emptied of refrigerant. Make sure to date and sign the label. For appliances containing flammable refrigerants, ensure that there are labels on the equipment stating it contains flammable refrigerant.

18. Recovery

When removing refrigerant from a system, either for servicing or decommissioning, it is recommended good practice to remove refrigerants safely. When transferring refrigerant into cylinders, ensure that only appropriate refrigerant recovery cylinders are employed. Ensure that the correct number of cylinders for holding the total system charge are available. Designate all the cylinders intended to be used for the recovered refrigerant and label them for that refrigerant (i.e., special cylinders for the recovery of refrigerant). Cylinders must be complete with pressure-relief valves. The associated shut-off valves must be in good working order. Evacuate empty recovery cylinders and, if possible, allow them to cool before recovery occurs.

The recovery equipment must be in good working condition with a set of instructions concerning the equipment that is at hand. In addition, the recovery equipment must be suitable for the recovery of the flammable refrigerant. If in doubt, consult the manufacturer. In addition, a set of calibrated weighing scales must be available and in good working order. Hoses must be complete with leak-free disconnect couplings and in good condition.

The recovered refrigerant must be processed according to local legislation in the correct recovery cylinder. In addition, the relevant waste transfer note must be arranged. Do not mix refrigerants in the recovery unit and especially not in the cylinders.

If removing compressors or compressor oils, ensure that they have been evacuated to an acceptable level to make sure that flammable refrigerant does not remain with the lubricant. The compressor body must not be heated by an open flame or other ignition sources to accelerate this process. When oil is drained from a system, it must be carried out safely.





19. Transportation, Marking, and Storage for Units

- Transport equipment containing flammable refrigerants (Compliance with the transport regulations).
- Mark the equipment using signs (Compliance with local regulations).
- Dispose of equipment using flammable refrigerants (Compliance with national regulations).
- Store the equipment/appliance (Compliance with the manufacturer's instructions).
- Store packed (unsold) equipment. Construct the storage package protection in a way that potential mechanical damage to the equipment inside the package will not cause a leak of the refrigerant charge. Local regulations determine the maximum amount of equipment permitted to be stored together.

Safety Precautions

1

Explanation of symbols displayed on the indoor or outdoor units

	WARNING	This symbol shows that this appliance used a flammable refrigerant. If the refrigerant is leaked and exposed to an external ignition source, there is a risk of fire.
	CAUTION	This symbol shows that the operation manual should be read carefully.
	CAUTION	This symbol shows that a service personnel should be handling this equipment with reference to the installation manual.
	CAUTION	
	CAUTION	This symbol shows that information is available such as the operating manual or installation manual.

Product Overview

2

Note

Illustrations in this manual are for explanatory purposes. The actual shape of the indoor unit may be slightly different. The actual shape shall prevail.

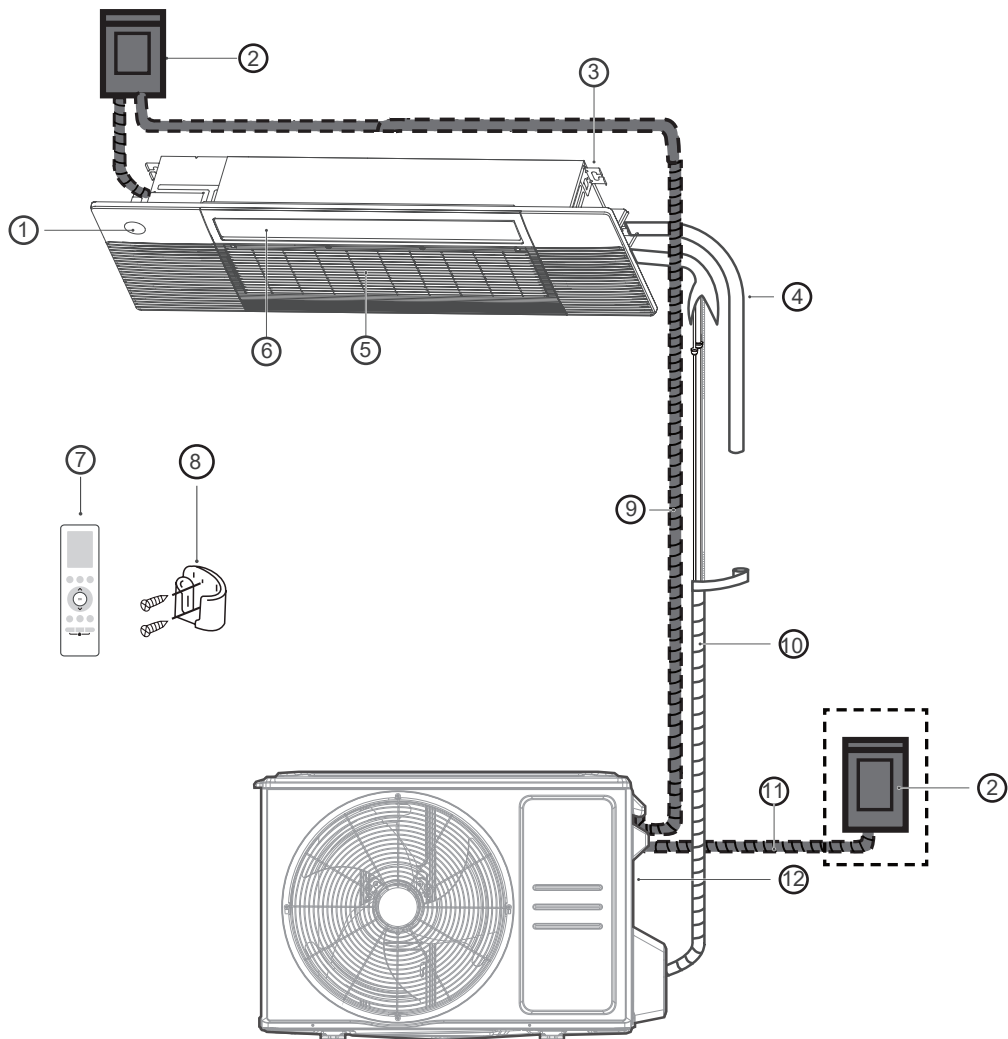

Note: Select a service disconnect meeting the requirements of the local, regional, and national codes.

- | | | |
|------------------------------------|--|--|
| ① Display panel | ⑤ Air inlet (with air filter in it) | ⑨ Connection cable (purchase separately) |
| ② Service disconnect | ⑥ Air outlet (Air flow louver) | ⑩ Refrigerant piping (purchase separately) |
| ③ Installation part | ⑦ Remote controller | ⑪ Outdoor unit power cable (purchase separately) |
| ④ Drain pipe (purchase separately) | ⑧ Remote controller holder (purchase separately) | ⑫ Outdoor unit |

Product Overview

2

Unit Parts

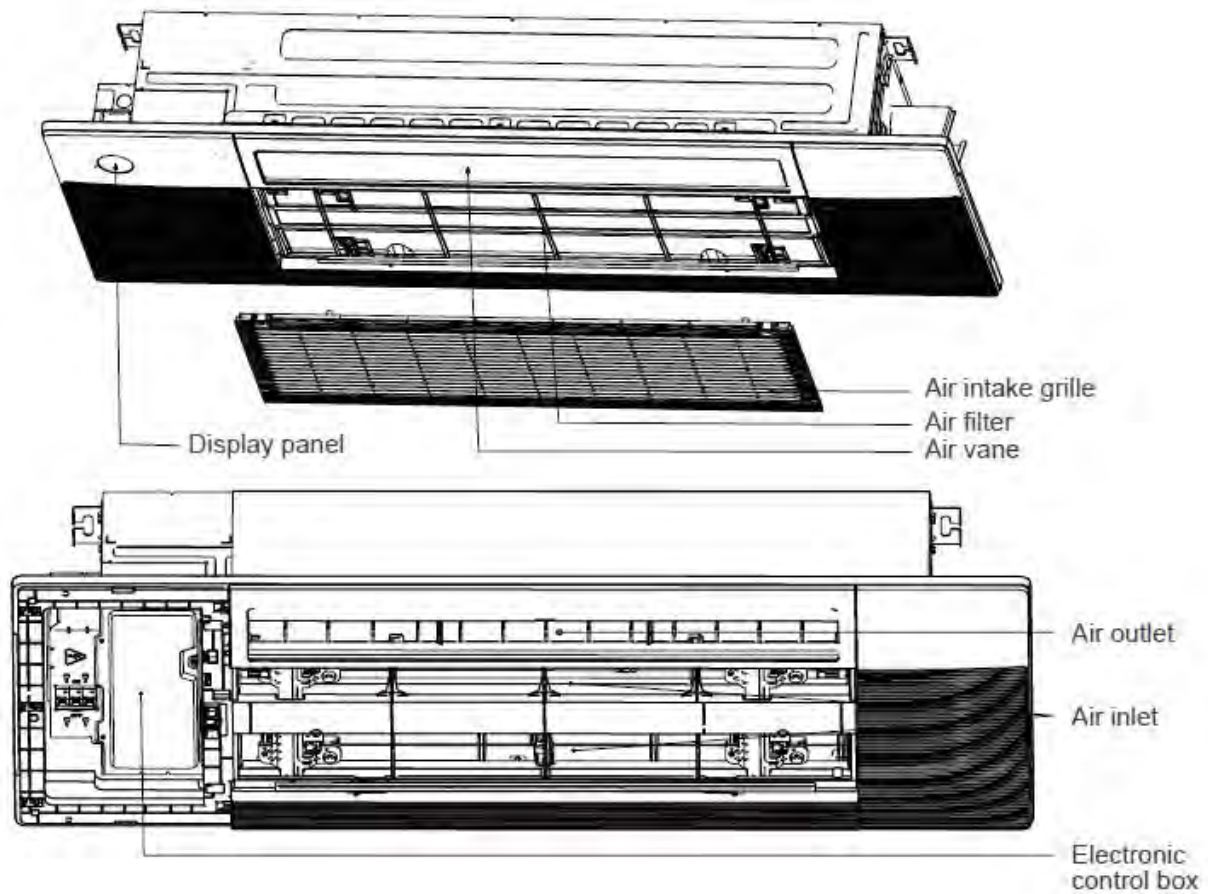











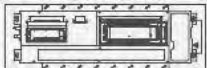

Product Installation

3

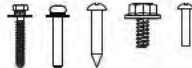
Accessories

The air conditioning system comes with the following accessories. Use all of the installation parts and accessories to properly install the air conditioner. Improper installation may result in water leakage, electrical shock and fire, or cause the equipment to fail. The items that are not included with the air conditioner must be purchased separately.

Name of Accessories	Qty	Shape	Name of Accessories	Qty	Shape
Manual	1		Water receiver	1	
Installation cardboard template	1		Rubber ring	1	
Remote controller	1		AAA Battery	2	
Cable tie	6		Copper nut	2	
Drainpipe adaptor	1		Screw kits (ST8*50, M4*22, ST3.9*16, ST4.8*12, ST3.9*10)	1 (8,8,2,2,3)	
Panel	1		Wired controller (purchase separately)	1	
Smart kit (purchase separately)	1		Remote controller holder (purchase separately)	1	

Optional Accessories

There are two types of remote controls: Wired and wireless.

Select a remote controller based on customer preferences and requirements. Install the remote control in an appropriate place. Refer to catalogues and technical literature for guidance on selecting a suitable remote controller.

Name	Model	Pipe Specification		Remark
		Liquid Side	Gas Side	
Connecting pipe assembly	9K	Φ 1/4 in (Φ 6.35 mm)	Φ 3/8 in (Φ 9.52 mm)	Pipes are not included in the accessories and need to be purchased separately from the local dealer.
	12K	Φ 1/4 in (Φ 6.35 mm)	Φ 3/8 in (Φ 9.52 mm)	
	18K	Φ 1/4 in (Φ 6.35 mm)	Φ 1/2 in (Φ 12.7 mm)	

Note: Install the panel after the wiring and piping have been completed.

Indoor Unit Installation

4

1 Select the Installation Location

Note

Before installing the indoor unit, choose an appropriate location. The following are standards that will help choose an appropriate location for the unit.

Before Installation:

- Determine the route for moving the unit to the installation site.
- First unseal and unpack the unit. Then, hold the seats of the hanger (4 pieces) to move the unit. Refrain from exerting force on other parts of the unit, especially the refrigerant piping, water discharge piping, and plastic parts.

Proper installation locations must meet the following standards:



- Enough room exists for installation and maintenance.



- There is no direct radiation from heaters.

- Enough room exists for connecting the pipe and drainpipe.



- The air inlet and outlet are not blocked.

- The airflow can fill the entire room.

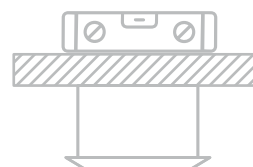

- The ceiling is horizontal and its structure can sustain the weight of the indoor unit.

Do not install the unit in the following locations:

- ⊘ Areas with oil drilling or fracking
- ⊘ Coastal areas with high salt content in the air
- ⊘ Areas with caustic gases in the air, such as hot springs
- ⊘ Areas that experience power fluctuations, such as factories
- ⊘ Enclosed spaces, such as cabinets
- ⊘ Kitchens that use natural gas
- ⊘ Areas with strong electromagnetic waves
- ⊘ Areas that store flammable materials or gas
- ⊘ Rooms with high humidity, such as bathrooms or laundry rooms

Indoor Unit Installation

4

2 Confirm Various Sizes

Installation Place

(Unit: inch/mm)

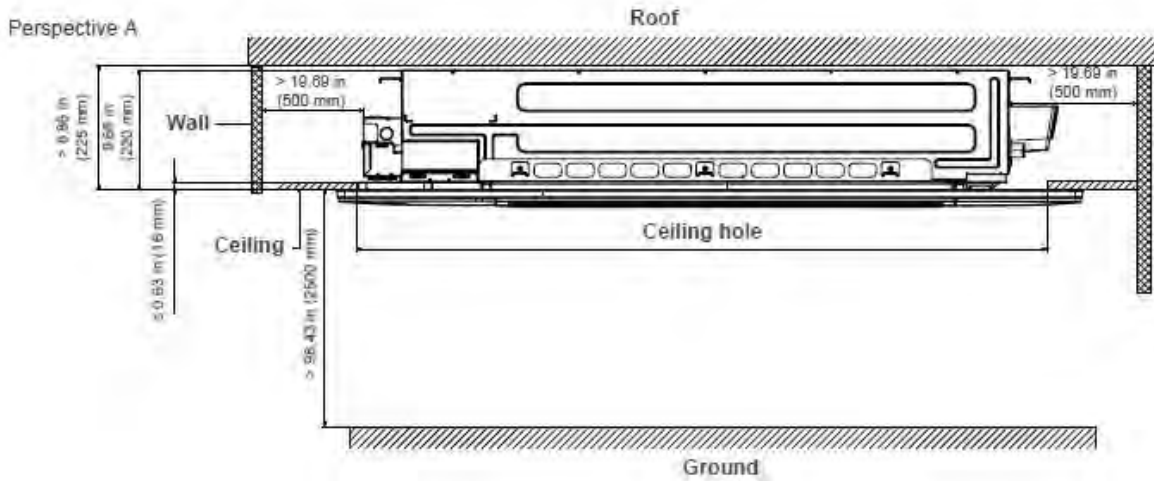

Perspective B

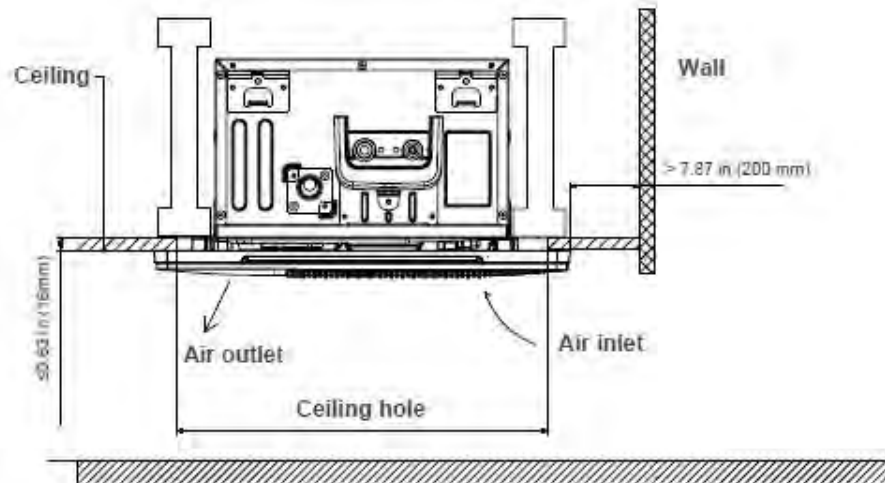

Indoor Unit Installation

4

Indoor Parts Installation Size

(unit: inch/mm)

Perspective A

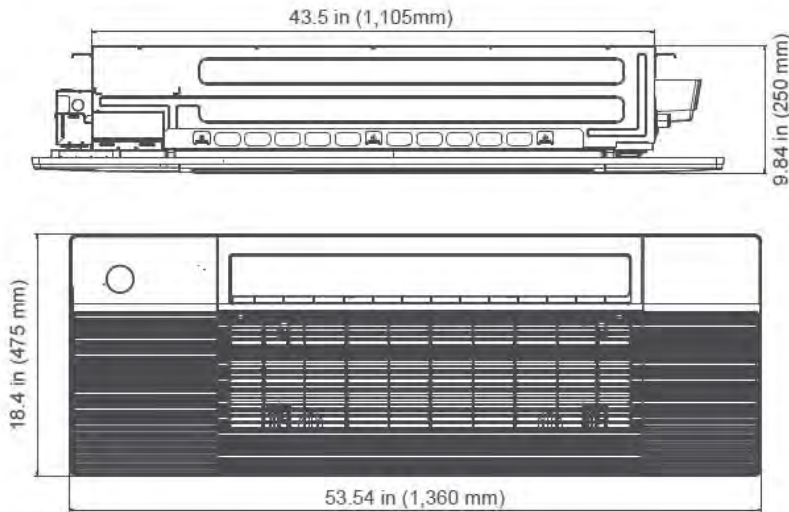

Perspective B

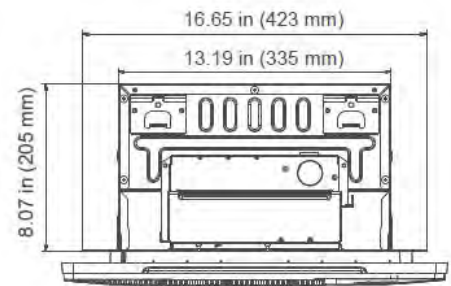

3 Indoor Unit Installation

Ensure that only specified components are used for the installation.

Step 1: (Model A with circuit breaker)

1. Remove the four screws to open the indoor control box and circuit breaker box.

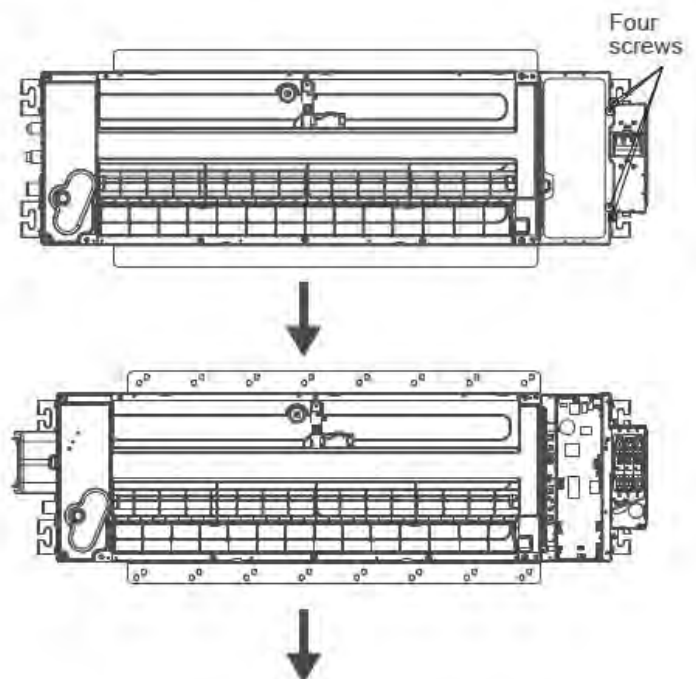

Indoor Unit Installation

4

2. Remove the pre-cutting cover on the circuit breaker box.

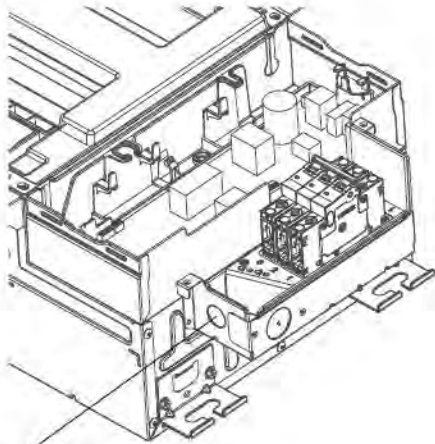

Pre-cutting cover

3. Connect the wire to the air breaker according to the wire connecting diagram.

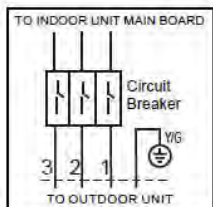
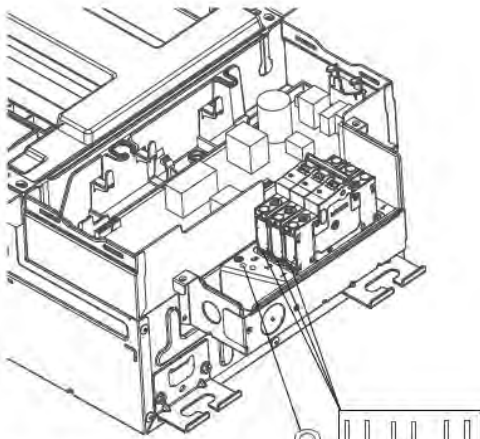

⚠ WARNING

The ground wire should be tightened firmly without loosening.

4. Fasten and fix the wire body with a tie.

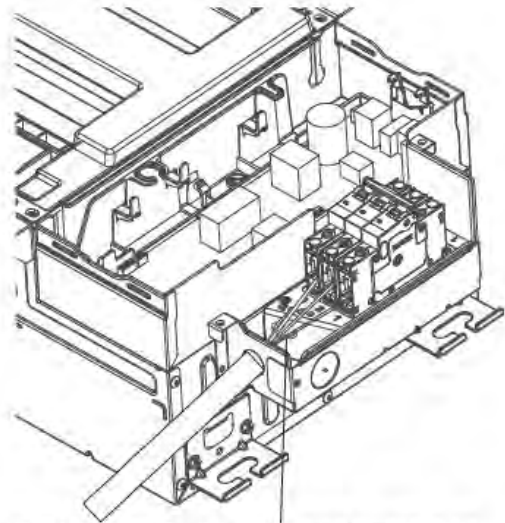

Fasten and fix the wire body with a tie

5. Install the circuit breaker cover by fixing the two screws.

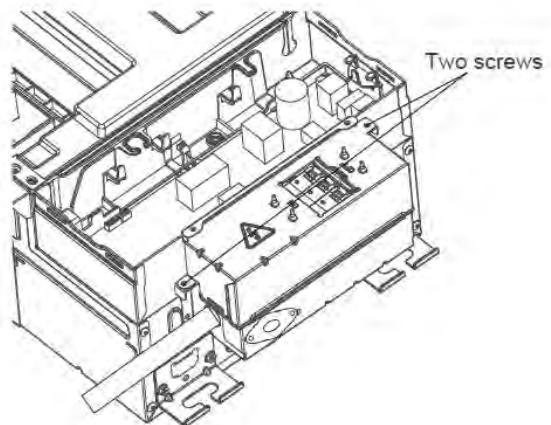

Two screws

Indoor Unit Installation

4

Step 1: (Model B with circuit breaker)

1. Remove the four screws to open the indoor control box and terminal box.

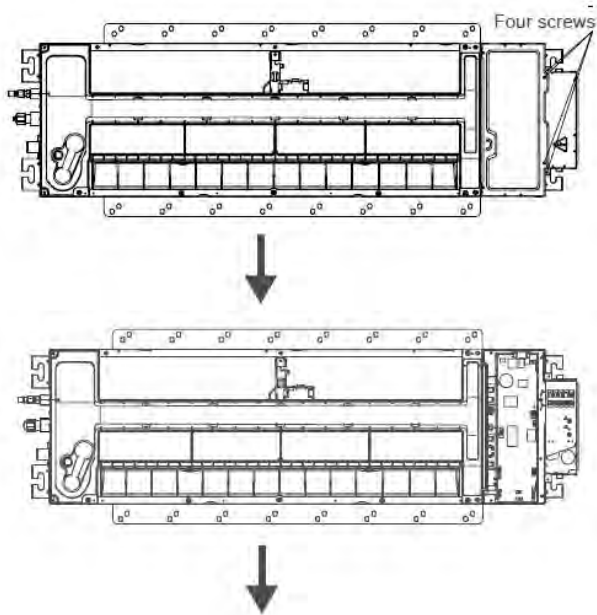

2. Remove the pre-cutting cover on the terminal box. Remove the two screws, then take out the clip.

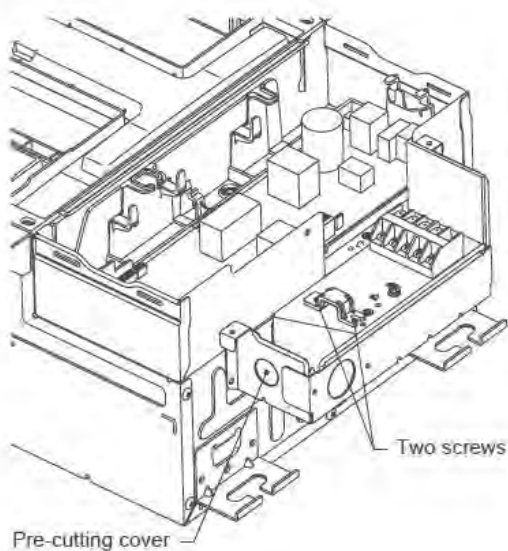

3. Connect the wire to the terminal according to the wire connecting diagram.

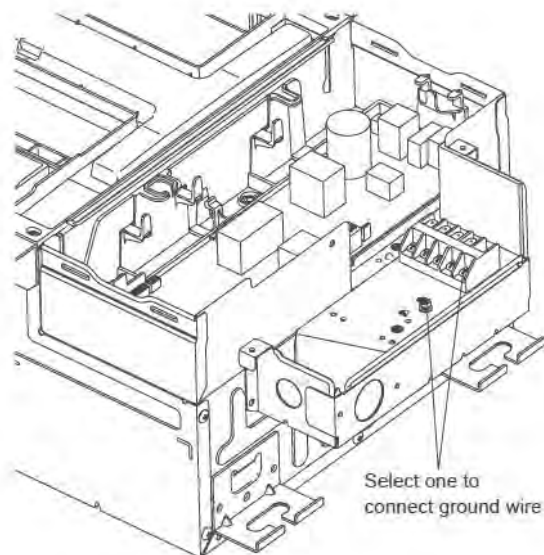

4. Fix the wire with the clip by using the two screws.

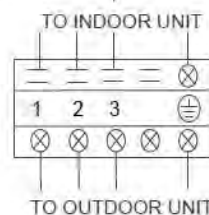
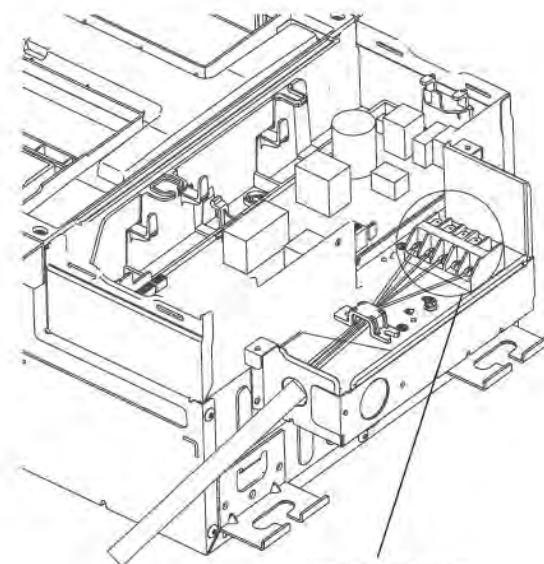

4

Indoor Unit Installation

5. Install the terminal cover by fixing the two screws.

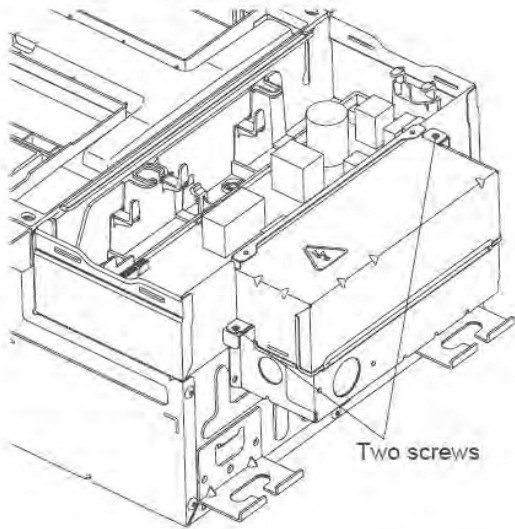

Step 2: Install the Indoor Air Handler

Note:

After finishing the installation of the main body, when choosing where to start, determine the direction of the pipes to be drawn out. Especially in cases where there is a ceiling involved, align the refrigerant pipes, drain pipes, and indoor and outdoor lines with their connection points before mounting the unit.

1. After the installation location is selected, drill a hole with a diameter of 0.2 inches (6 mm) or less into the roof beam. This is based on the layout of the installation board (accessory installation cardboard template). After drilling the hole, remove the installation board.

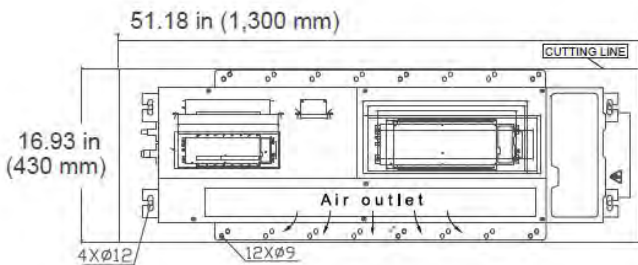

2. Connect the wire from the control box.

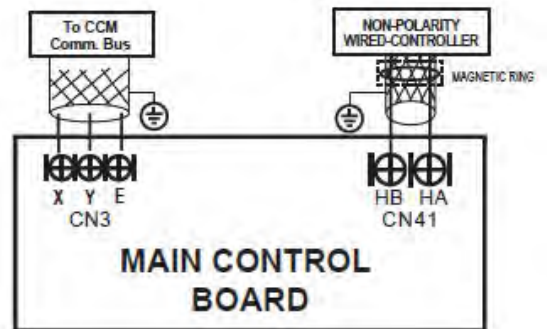

Indoor Unit Installation

4

3. Connect the other side of the connecting cable to the wired controller.

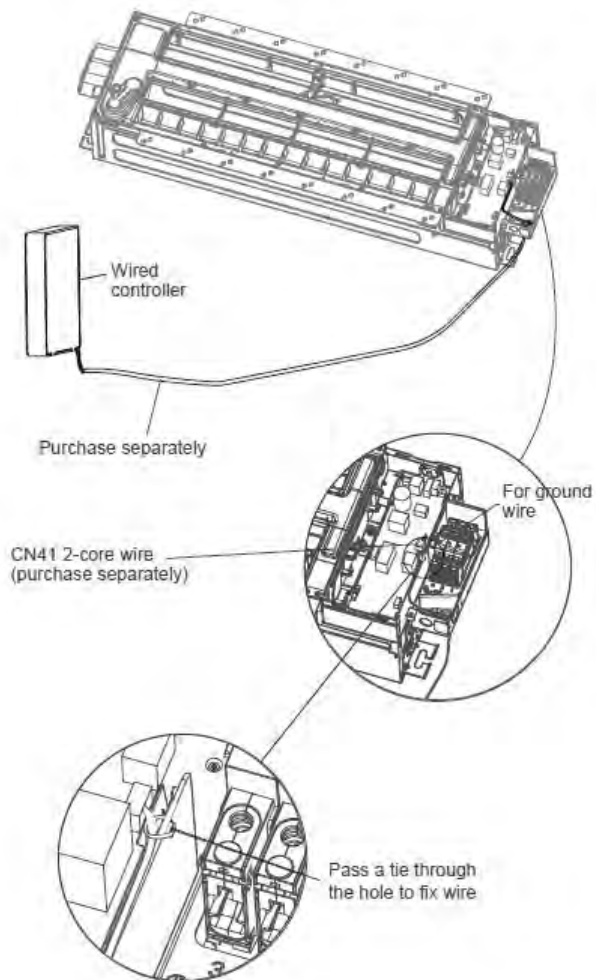

⚠ WARNING

Follow the local regulations and take measures to isolate high and low voltage.

Note:

Be sure to reserve a length of the connecting wire for periodic maintenance. If there is a connection lug at the end of the shielded wire, properly ground the connection lug.

Outdoor Unit Installation

5

1 Select the Installation Location



Note: Prior to Installation

Before installing the outdoor unit, choose an appropriate location. The following are standards intended to help select an appropriate location for the unit.

Proper installation locations must meet the following standards:

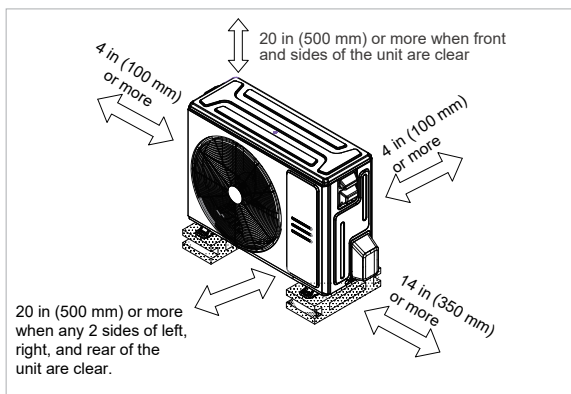

Good air circulation and ventilation.



Firm and solid—the location can support the unit and will not vibrate.



Noise from the unit will not disturb other people.



Protected from prolonged periods of direct sunlight or rain.



Where snowfall is anticipated, take appropriate measures to prevent ice buildup and coil damage.

Meets all spatial requirements shown in the installation clearance requirements above.



Note: Install the unit by following local codes and regulations, which can differ slightly between different regions.

CAUTION:

Special Considerations for Extreme Weather

If the unit is exposed to heavy wind:

Install the unit so that the air outlet fan is at 90° angle to the direction of the wind. If needed, build a barrier in front of the unit to protect it from extremely heavy winds. See the figures below:

If the unit is frequently exposed to heavy rain or snow:

Build a shelter above the unit to protect it from rain or snow. Be careful not to obstruct air flow around the unit.

If the unit is frequently exposed to salty air (seaside):

Use an outdoor unit that is specially designed to resist corrosion.

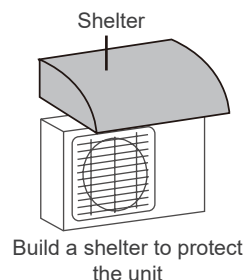
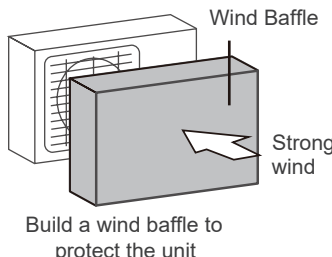
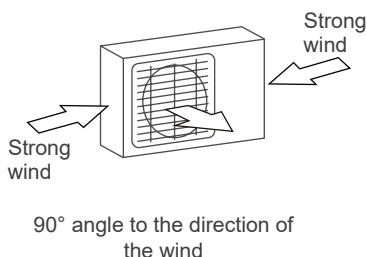

Outdoor Unit Installation

5

Do not install the unit in the following locations:

- ⊘ Near an obstacle that will block air inlets and outlets.
- ⊘ Near animals or plants that will be harmed by hot air discharge.
- ⊘ In a location that is exposed to large amounts of dust.
- ⊘ Near public streets, crowded areas, or where noise from the unit will disturb others.
- ⊘ Near any source of combustible gas.
- ⊘ In a location exposed to an excessive amount of salty air.

2 Install the Drain Joint

Step 1:

Find the base pan hole of the outdoor unit.

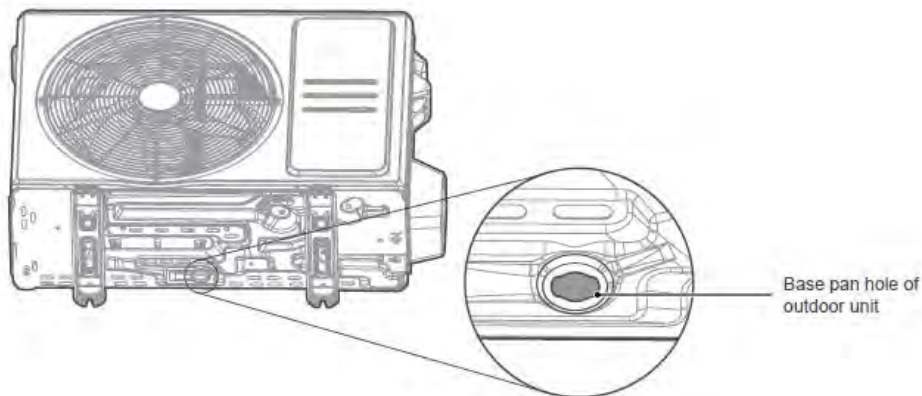

Step 2:

1. Fit the rubber seal on the end of the drain joint that will connect to the outdoor unit.
2. Insert the drain joint into the hole of the unit's base pan. The drain joint will click into place.
3. Connect a drain hose extension (not included) to the drain joint to redirect water from the unit during Heating mode.

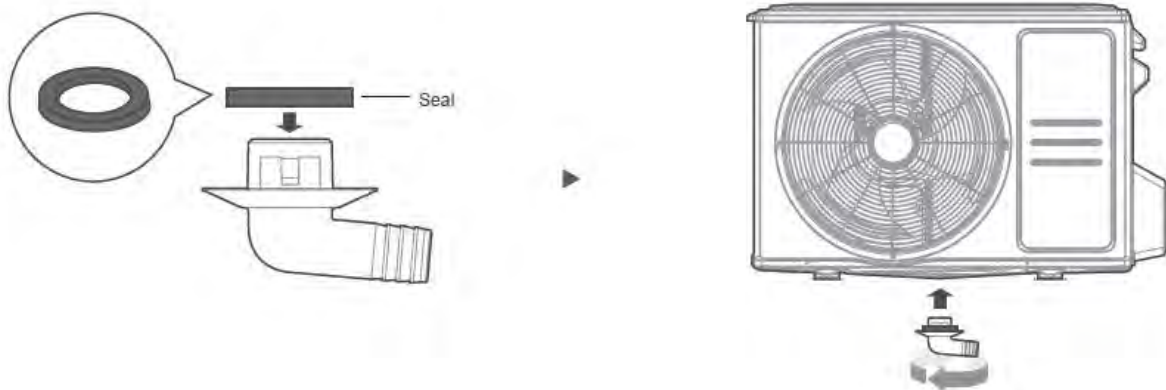

Outdoor Unit Installation

5

! In Cold Climates

In cold climates, make sure that the drain hose is as vertical as possible to ensure swift water drainage. If water drains too slowly, it can freeze in the hose and flood into the unit.

3 Anchor the Outdoor Unit

! WARNING

When drilling into concrete, eye protection is recommended at all time.

Anchor the outdoor unit to the ground or a wall-mounted bracket with bolts (M10). Prepare the installation base of the unit according to the dimensions below.

The following is a list of different outdoor unit sizes and the distance between their mounting feet. Prepare the installation base of the unit according to the dimensions below.

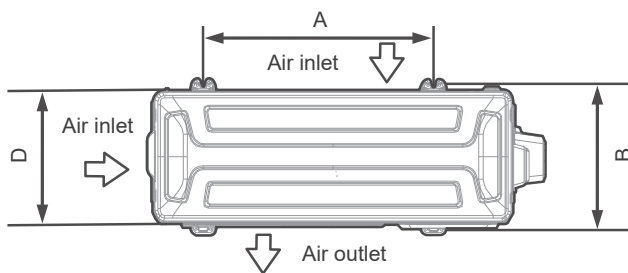

Top View

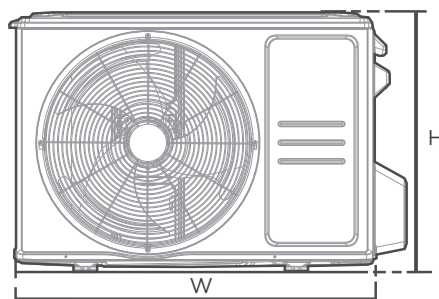

Front View

Outdoor Unit Dimensions W x H x D	Mounting Dimensions	
	Distance A	Distance B
30.1 in x 21.8 in x 11.9 in (765 mm x 555 mm x 303 mm)	17.8 in (452 mm)	11.3 in (286 mm)
31.7 in x 21.8 in x 12.9 in (805 mm x 555 mm x 330 mm)	20.1 in (511 mm)	12.5 in (317 mm)
35.0 in x 26.5 in x 13.5 in (890 mm x 673 mm x 342 mm)	26.1 in (663 mm)	13.9 in (354 mm)



Outdoor Unit Installation

5

Rows of Series Installation

	L	A
$L \leq H$	$L \leq 1/2H$	9.8 in (248.9 mm) or more
	$1/2H < L \leq H$	11.8 in (299.7 mm) or more
$L > H$	Cannot be installed	

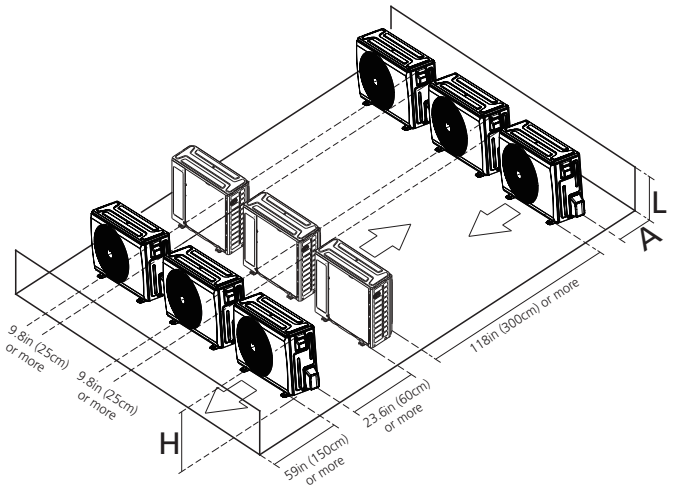

Note:

H: Unit height

L: Height of the wall behind the unit

A: Distance between the unit and wall

If installing the outdoor unit on the ground or a concrete mounting platform, follow these steps:

1. Mark the positions for the four expansion bolts based on the dimensions in the Mounting Dimensions chart and illustrations above.
2. Pre-drill holes for the expansion bolts.
3. Clean concrete dust away from the holes.
4. Place a nut on the end of each expansion bolt.
5. Hammer the expansion bolts into the pre-drilled holes.
6. Remove the nuts from the expansion bolts, then place the outdoor unit on bolts.
7. Put a washer on each of the expansion bolts, then reinstall the nuts.
8. Use a wrench to tighten each nut until snug.

Outdoor Unit Installation

5

If installing the unit on a wall-mounted bracket, follow these steps:

CAUTION:

Before installing a wall-mounted unit, make sure that the wall is made of solid brick, concrete, or a similarly strong material. The wall must be able to support at least four times the weight of the unit.

1. Mark the position of the bracket holes based on the dimensions in the Mounting Dimensions chart on the previous page.
2. Pre-drill the holes for the expansion bolts.
3. Clean dust and debris away from the holes.
4. Place a washer and nut on the end of each expansion bolt.
5. Thread expansion bolts through the holes in the mounting bracket. Then, put the mounting brackets in position and hammer the expansion bolts into the wall.
6. Confirm that the mounting brackets are level.
7. If the feet of the outdoor unit have rubber pads already installed and are using a local dealer's wall-mounting bracket, remove them before attempting to mount the condenser to the bracket. The mounting bracket has rubber isolating pads on it that will take the place of these.
8. Carefully lift the unit and place its mounting feet on the brackets.
9. Bolt the unit firmly to the brackets.

To Reduce Vibration of the Wall-Mounted Unit

If allowed, install the wall-mounted unit with rubber gaskets to reduce vibration and noise.

Drainpipe Installation

The drainpipe is used to drain away water from the unit. Improper installation may cause unit and property damage.

- Insulate all piping to prevent condensation, which could lead to water damage.
- If the drainpipe is bent or installed incorrectly, water may leak and cause a water-level switch malfunction.
- In Heat mode, the outdoor unit will discharge water. Ensure that the drain hose is placed in an appropriate area to avoid water damage and slippage.
- Do not pull the drainpipe forcefully. This could disconnect it.
- Ensure that the drainpipe installation complies with all local and national codes and regulations.

Outdoor Unit Installation

5

Note on Purchasing Pipes

Installation requires 3/4 inch PVC pipe, which can be obtained at a local hardware store or dealer.

Indoor Drainpipe Installation

Install the drainpipe as illustrated in the following figure. Connect the drainpipe to the indoor unit via the drain adaptor.

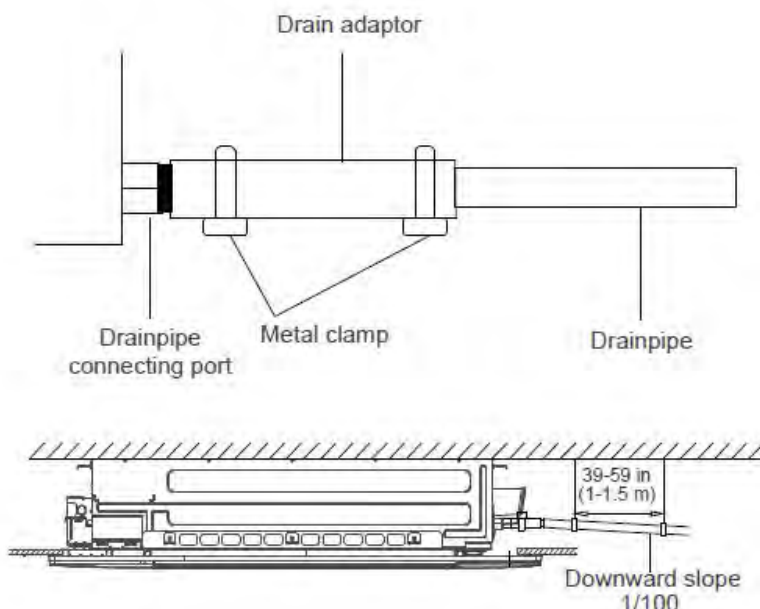

Note on Drainpipe Installation

- When using an extended drainpipe, tighten the indoor connection with an additional protection tube to prevent it from pulling loose.
- Slope the drainpipe downward at a gradient of at least 1/100 to prevent water from flowing back into the air conditioner.
- To prevent the pipe from sagging, space hanging wires every 39-59 inches (1-1.5 m).
- If the outlet of the drainpipe is higher than the body's pump joint, provide a lift pipe for the exhaust outlet of the indoor unit. Install the lift pipe no higher than 20.8 inches (528 mm) from the drain port on the cassette. Ensure that the distance between the unit and lift pipe is less than 11.8 inches (279 mm). Incorrect installation could cause water to flow back into the unit and flood.
- To prevent air bubbles, keep the drain hose level or slightly tilted up (< 3 in / 75 mm).

Outdoor Unit Installation

5

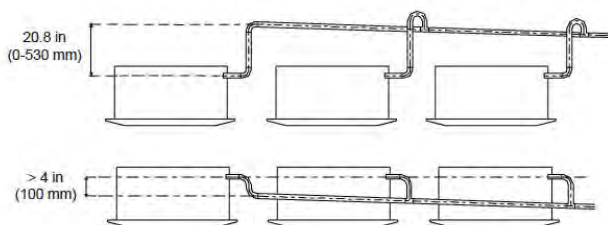
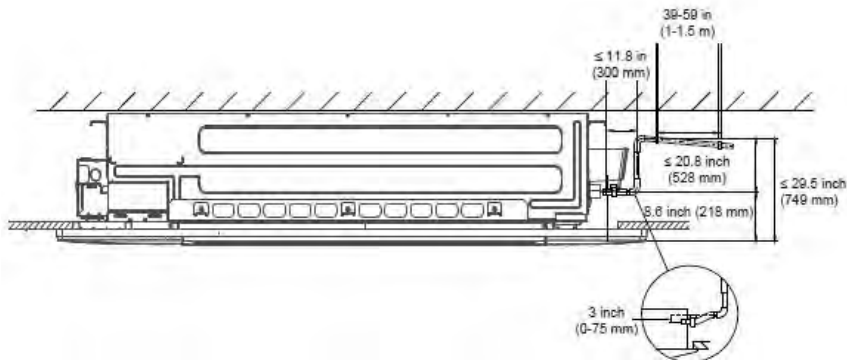

Pass the drain hose through the wall hole. Make sure the water drains to a safe location so it will not cause water damage or a slipping hazard.

Note:

Ensure that the drainpipe outlet is at least 1.9 inches (50 mm) above the ground. If it touches the ground, the unit may become blocked and malfunction. If discharging the water directly into a sewer, make sure that the drain has a U or S pipe to catch odors that might otherwise come back into the house.

Drill the Wall Hole

1. Use a 2.5 inch (65 mm) or 3.54 inch (90 mm) core drill to create a hole in the wall. Make sure that the hole is drilled at a slight downward angle, so that the outdoor end of the hole is lower than the indoor end by about 0.2-0.275 inches (5-7 mm). This will ensure proper water drainage.
2. Place the protective wall cuff in the hole. This protects the edges of the hole and will help seal it when finishing the installation process.

CAUTION:

When drilling the wall hole, make sure to avoid wires, plumbing, and other sensitive components.

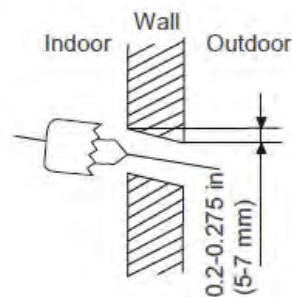

Note: When the gas side connective pipe is Φ 5/8 inches (16 mm) or more, the wall hole must be 3.54 inches (90 mm)



Refrigerant Piping Connection

6

When connecting the refrigerant piping, do not let substances or gases other than the specified refrigerant from entering the unit. The presence of other gases or substances will lower the unit's capacity, and can cause abnormally high pressure in the refrigeration cycle. This can cause an explosion and injury.

Notes on Pipe Length & Elevation

Maximum Length & Drop Height Based on Models

Ensure that the length of the refrigerant pipe, number of bends, and drop height between the indoor and outdoor units meet the requirements shown in the table:

Model	Length of Piping	Maximum Drop Height
9K/12K	82 ft / 25 m	49.2 ft / 15 m
18K	98.4 ft / 30 m	65.6 ft / 20 m

CAUTION

Oil Traps

If oil flows back into the outdoor unit's compressor, this might cause liquid compression or deterioration of oil return. Oil traps in the rising gas piping can prevent this.

Install an oil trap every 20 feet (6 m) of vertical suction line riser (<36K). Install an oil trap every 32.8 feet (10 m) of vertical suction line riser (\geq 36K).

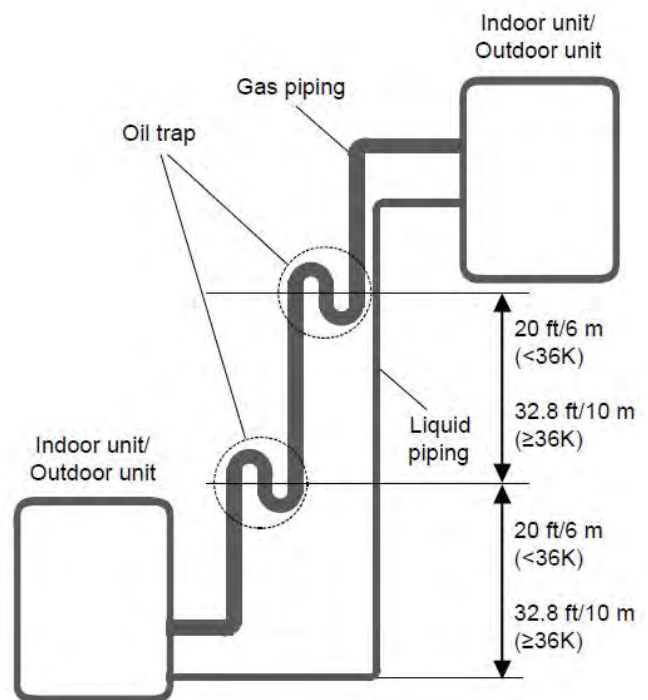

Refrigerant Piping Connection

6

Connection Instructions - Refrigerant Piping

⚠ CAUTION

- Install the branching pipe horizontally. An angle of more than 10° may cause malfunctions.
- Do not install the connecting pipe until both the indoor and outdoor units have been installed.
- Insulate both gas and liquid piping to prevent condensation.

Step 1: Cut Pipes

When preparing the refrigerant pipes, take extra care to cut and flare them properly. This will ensure efficient operation and minimize the need for future maintenance.

1. Measure the distance between the indoor and outdoor units.
2. Use a pipe cutter to cut the pipe a little longer than the measured distance.
3. Make sure that the pipe is cut at a perfect 90° angle.

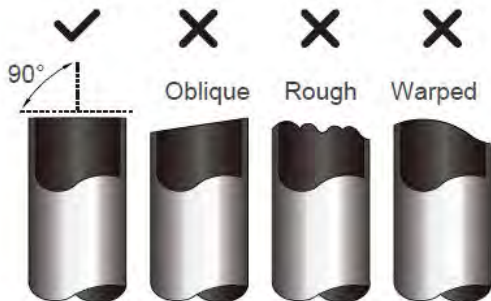

💡 Do Not Deform the Pipe While Cutting

Be careful not to damage, dent, or deform the pipe while cutting. This will drastically reduce the heating efficiency.

Step 2: Remove Burrs

Burrs can affect the air-tight seal of the refrigerant piping connection. They must be completely removed.

1. Hold the pipe at a downward angle to prevent burrs from falling into the pipe.
2. Use a reamer or deburring tool to remove all the burrs from the cut section of the pipe.

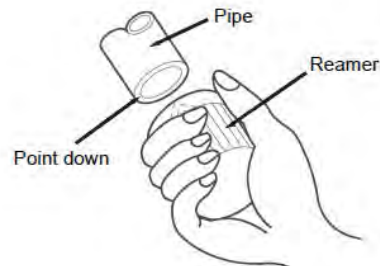

Step 3: Flare Pipe Ends

Proper flaring is essential to achieve an airtight seal.

1. After removing burrs from the cut pipe, seal the ends with PVC tape to prevent foreign materials from entering the pipe.
2. Sheath the pipe with insulating material.
3. Place flare nuts on both ends of the pipe. Make sure they are facing the correct direction, because it is not possible to change their direction after flaring.

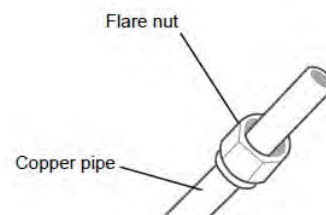

4. Remove the PVC tape from the ends of the pipe when ready to perform the flaring work.

6

Refrigerant Piping Connection

Step 3: Flare Pipe Ends (Continued)

5. Clamp the flare form on the end of the pipe. The end of the pipe must extend beyond the flare form.

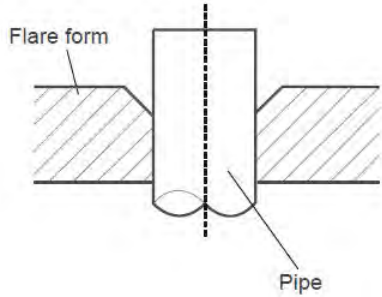

- 6. Place the flaring tool onto the form.
- 7. Turn the handle of the flaring tool clockwise until the pipe is fully flared.

Pipe Gauge	Tightening Torque	Flare Dimension (A)	Flare Shape
Ø ¼ in (6.35 mm)	18-20 N.m (180-200 kgf.cm)	0.33~0.34 in (8.4~8.7 mm)	
Ø ⅜ in (9.52 mm)	32-39 N.m (320-390 kgf.cm)	0.52~0.53 in (13.2~13.5 mm)	
Ø ½ in (12.7 mm)	49-59 N.m (490-590 kgf.cm)	0.64~0.65 in (16.2~16.5 mm)	

8. Remove the flaring tool and flare form, then inspect the end of the pipe for cracks and flaring.

Step 4: Connect Pipes

Connect the copper pipes to the indoor unit first, then connect it to the outdoor unit. Connect the low-pressure pipe, then the high-pressure pipe.

- 1. When connecting the flare nuts, apply a thin coat of refrigeration oil to the flared ends of the pipes.
- 2. Align the center of the two pipes intended to be connected.

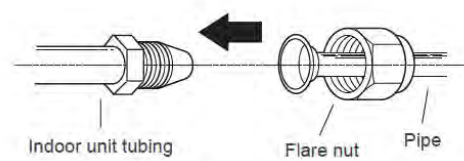

- 3. Tighten the flare nut snugly by hand.
- 4. Use a wrench to grip the nut on the unit tubing.
- 5. While firmly gripping the nut, use a torque wrench to tighten the flare nut according to the torque values in the table.

Note

Use both a spanner and torque wrench when connecting or disconnecting pipes to/from the unit.



Refrigerant Piping Connection

6

⚠ CAUTION

Ensure to wrap the insulation around the piping. Direct contact with the bare piping may result in burns or frostbite.

- Make sure the pipe is properly connected. Over tightening may damage the bell mouth, while under tightening may lead to leakage.

💡 Note

Minimum Bend Radius

- Carefully bend the tubing in the middle according to the diagram.
- Do not bend the tubing more than 90° or more than three times.

Use appropriate tool

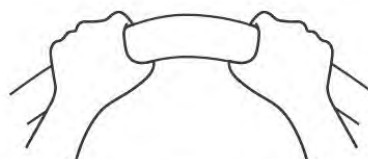

Min-radius 3.9 inch (99 mm)

Step 4: Connect Pipes (Continued)

6. After connecting the copper pipes to the indoor unit, wrap the power cable, signal cable, and piping together with binding tape.

7. Thread this pipeline through the wall and connect it to the outdoor unit.

8. Insulate all the piping, including the valves of the outdoor unit.

9. Fix the water receiver (supplied in the accessories box) to the indoor unit using a screw.

10. Open the stop valves of the outdoor unit to start the flow of the refrigerant.

💡 Note

- Do not intertwine the signal cable with other wires while bundling these items together.
- Do not intertwine or cross the signal cable with any other wiring.

⚠ CAUTION

Check to make sure that there is no refrigerant leakage after completing the installation work. If there is refrigerant leakage, ventilate the area immediately and evacuate the system. Refer to the Air Evacuation section of this manual.

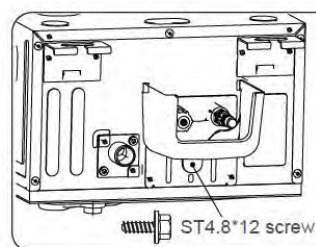

Note:
Two ST4.8*12 screws are supplied, one of which is spare.

ST4.8*12 screw

Wiring Precautions

7

⚠ WARNING

Before performing any electrical work, read these warnings.

- All wiring must comply with local and national electrical codes and regulations. A licensed electrician must install all the wiring.
- All electrical connections must be made according to the electrical connection diagram located on the panels of the indoor and outdoor units.
- If there is a serious safety issue with the power supply, stop work immediately. Explain the reasoning to the client and refuse to install the unit until the safety issue is properly resolved.
- The power voltage must be within 90-110% of the rated voltage. Insufficient power supply can cause malfunction, electrical shock, or fire.
- Installing an external surge suppressor at the outdoor disconnect is recommended.
- If connecting power to fixed wiring, incorporate a switch or circuit breaker that disconnects all poles and has a contact separation of at least 1/8 of an inch (3 mm). Qualified technicians must use an approved circuit breaker or switch.
- Only connect the unit to an individual branch circuit. Do not connect another appliance to that outlet.
- Make sure to properly ground the air conditioner.
- Firmly connect every wire. Loose wiring can cause the terminal to overheat, resulting in product malfunction and possible fire.
- Do not let wires touch or rest against the refrigerant tubing, compressor, or any moving parts.
- If the unit has an auxiliary electric heater, install it at least 3.3 feet (1 m) away from any combustible materials.
- After turning off the power, always wait 10 minutes or more before touching the electrical components in order to avoid electrical shock.
- Do not cross the electrical wiring with the signal wiring. This may cause distortion, interference, or possibly damage to circuit boards.
- Do not connect other equipment to the same power circuit.
- Connect the outdoor wires before connecting the indoor wires.

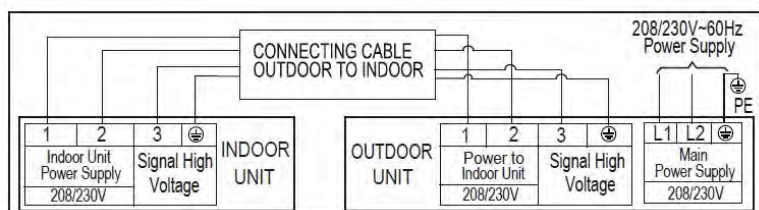

Connection Diagram (9K/12K/18K)

⚠ WARNING

Before performing any electrical or wiring work, turn off the main power to the system.

Wiring Precautions

7

Note for Service Disconnect

When the maximum current of the air conditioner is more than 16A, use a service disconnect or leakage protection switch with a protective device (purchased separately). When the maximum current of the air conditioner is less than 16A, equip the power cord of the air conditioner with a plug (purchased separately). In North America, wire the appliance according to NEC and CEC requirements.

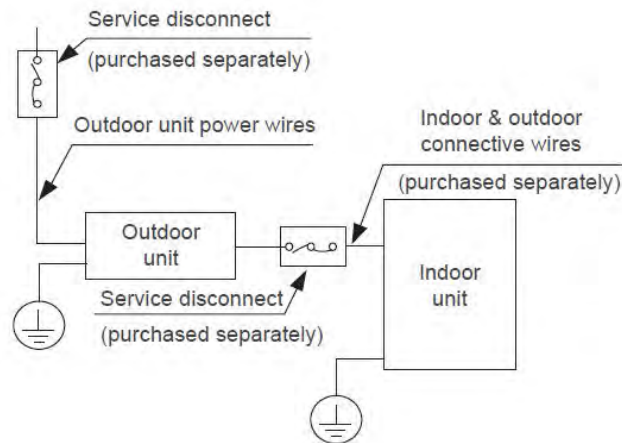

Note: The diagrams are for explanation purposes only. The machine may be slightly different. The actual shape shall prevail.

Select the service disconnect as required by local, regional, and national codes.

Wiring Precautions

7

Outdoor Unit Wiring

⚠ WARNING

Before performing any electrical or wiring work, turn off the main power to the system.

1. Prepare the cable for connection:

- a) Begin by choosing the correct cable size. Choose the cable type according to the local electrical codes and regulations.
- b) The minimum circuit ampacity of the unit determines the size of the power supply cable, signal cable, fuse, and switch needed. The minimum circuit ampacity is indicated on the nameplate located on the side panel of the unit. Refer to the nameplate to choose the correct cable, fuse, or switch.
- c) Use wire strippers to strip the rubber jacket from both ends of the signal cable to reveal approximately 5.9 inches (150 mm) of wire.
- d) Strip the insulation from the ends of the cable.
- e) Use a wire crimper to crimp u-lugs on the ends.

Note: When connecting the wires, strictly follow the wiring diagram inside the electrical box cover.

2. Remove the electric cover of the outdoor unit. If there is no cover on the outdoor unit, take off the bolts from the maintenance board and remove the protection board.

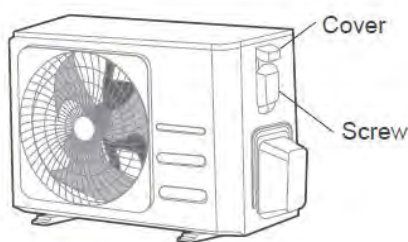

3. Connect the u-lugs to the terminals. Match the wire colors/labels with the labels on the terminal block. Firmly screw the u-lug of each wire to its corresponding terminal.
4. Clamp down the cable with the cable clamp.
5. Insulate unused wires with electrical tape. Keep them away from any electrical or metal parts.
6. Reinstall the cover of the electrical control box.

Wiring Precautions

7

Indoor Unit Wiring

1. Prepare the cable for connection:

- a) Use wire strippers to strip the rubber jacket from both ends of the signal cable to reveal about 5.9 inches (150 mm) of the wire.
- b) Strip the insulation from the ends of the wires.
- c) Use a wire crimper to crimp the u-lugs to the ends of the wires.

2. Open the front panel of the indoor unit. Use a screwdriver to remove the cover of the electric control box on the indoor unit.

3. Thread the power and signal cables through the wire outlet.

4. Connect the u-lugs to the terminals. Match the wire colors/labels with the labels on the terminal block. Firmly screw the u-lug of each wire to its corresponding terminal. Refer to the serial number and wiring diagram located on the cover of the electric control box.

5. Clamp down the cable with the cable clamp. The cable must not be loose or pull on the u-lugs.

6. Reattach the electric box cover.

CAUTION

- While connecting the wires, strictly follow the wiring diagram.
- The refrigerant circuit can become very hot. Keep the interconnection cable away from the copper tube.

Air Evacuation

8

Notice

When opening the valve stems, turn the hexagonal wrench until it hits against the stopper. Do not try to force the valve to open further.

Preparations & Precautions

Air and foreign matter in the refrigerant circuit can lead to abnormal rises in pressure, which can damage the air conditioner, reduce its efficiency, and cause injury. Use a vacuum pump and manifold gauge to evacuate the refrigerant circuit, removing any non-condensable gas and moisture from the system. Perform the evacuation after the initial installation and when relocating the unit.

Before Performing the Evacuation

- ☑ Check to make sure the connective pipes between the indoor and outdoor units are connected properly.
- ☑ Check to make sure all wiring is connected properly.

Evacuation Instructions

1. Connect the charge hose of the manifold gauge to the service port on the outdoor unit's low-pressure valve.
2. Connect another charge hose from the manifold gauge to the vacuum pump.
3. Open the low-pressure side of the manifold gauge. Keep the high-pressure side closed.
4. Turn on the vacuum pump to evacuate the system.
5. Run the vacuum for at least 15 minutes or until the compound meter reads -76cmHg (-10^5Pa).

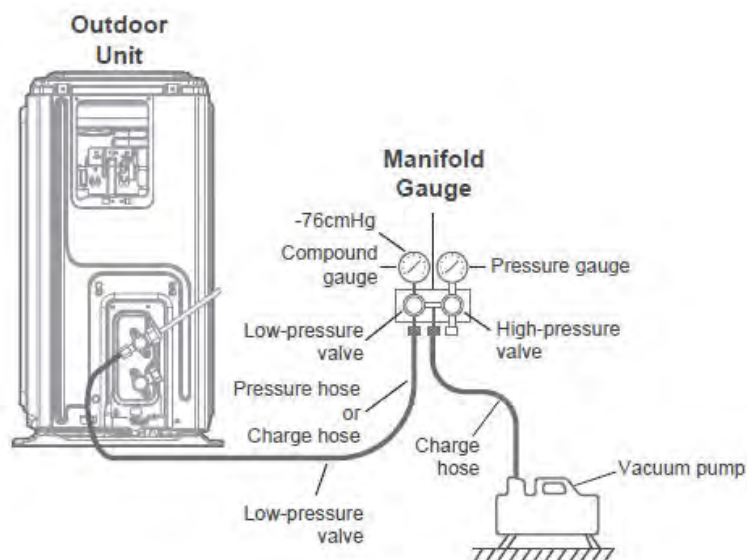

Air Evacuation

8

6. Close the low-side pressure of the manifold gauge, then turn off the vacuum pump.
7. Wait for 5 minutes, then confirm that there has been no change in system pressure.
8. If there is a change in system pressure, refer to the information on how to check for leaks. If there is no change in system pressure, unscrew the cap from the packed valve (high-pressure valve),
9. Insert a hexagonal wrench into the packed valve (high-pressure valve) and open the valve by turning the wrench 1/4 counterclockwise. Listen for gas exiting the system, then close the valve after 5 seconds.
10. Watch the pressure gauge for 1 minute to make sure that there is no change in pressure. The pressure gauge should read slightly higher than the atmospheric pressure.
11. Remove the charge hose from the service port.

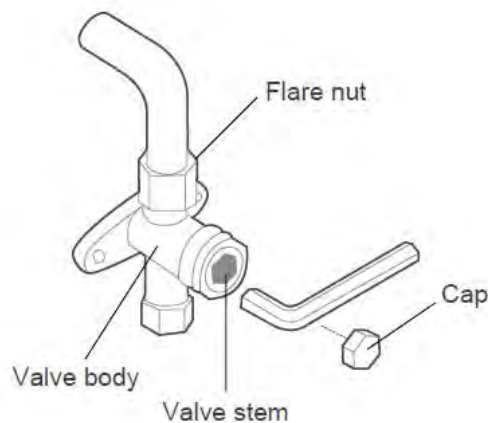

12. Use a hexagonal wrench to fully open both the high-pressure and low-pressure valves.
13. Tighten the caps on all three valves by hand (service port, high pressure, and low pressure). Use a torque wrench to tighten it further.

Note on Adding Refrigerant

9

CAUTION

Do not mix different types of refrigerant.

Some systems require additional charging depending on the pipe lengths. In North America, the standard pipe length is 25 feet (7.5 m). Charge the refrigerant from the service port on the outdoor unit's low-pressure valve. Calculate the additional refrigerant to be charged using the following formula:

Refrigerant	Liquid Side Diameter		
	Ø¼ in (Ø6.35 mm)	Ø¾ in (Ø9.52 mm)	Ø½ in (Ø12.7 mm)
R-454B	(Pipe length - standard length) x 0.16oz/ft (Pipe length - standard length) x 15g/m	(Pipe length - standard length) x 0.32oz/ft (Pipe length - standard length) x 30g/m	(Pipe length - standard length) x 0.69oz/ft (Pipe length - standard length) x 65g/m

Electrical & Gas Leak Checks

10

⚠ WARNING – RISK OF ELECTRICAL SHOCK

A licensed electrician must install all wiring and comply with local, state, and national electrical codes.

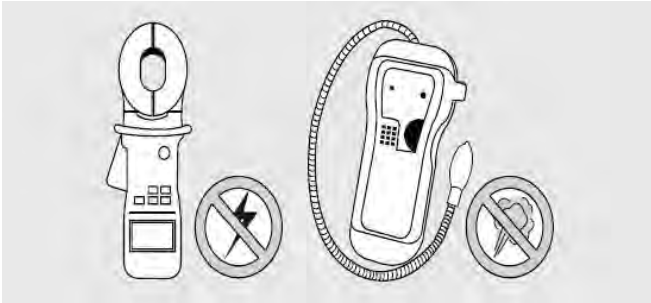

Electrical Safety Checks

After the installation is completed, confirm that all electrical wiring has been installed in accordance with local and national regulations, as well as according to the installation manual.

Before Test Run

Check Grounding Work
Measure grounding resistance using visual detection and a grounding resistance tester. The grounding resistance must be less than 0.1Ω .

Note: This may not be required for some locations in North America.

During Test Run

Check for Electrical Leakage
During the test run, use an electro probe and multimeter to perform a comprehensive electrical leakage test.

If Electrical Leakage is Detected

If electrical leakage is detected, turn off the unit immediately and call a licensed electrician to find and resolve the cause of leakage.

Gas Leak Checks

There are two different methods to check for gaseous leaks. Use Figure 8.1 below as a guide for the critical points to check for leaks.

Soap and Water Method

Use a soft brush or spray bottle to apply a soapy water solution to all of the pipe connection points of the indoor and outdoor units. Watch to see if any bubbles form. The presence of bubbles indicates there is a leak.

Leak Detector Method

If using a leak detector, refer to the device's Operation/Instruction manual for proper usage instructions.

After Performing Gas Leak Checks

After confirming that all of the refrigerant pipe connections points do not leak, replace the valve cover on the outside unit. Then, wrap and insulate the piping connections of the indoor unit.

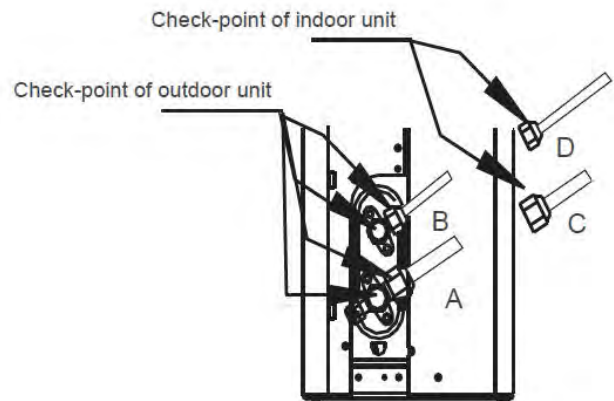

A: Low pressure stop valve
B: High pressure stop valve
C & D: Indoor unit flare nuts

Figure 8.1

Panel Installation

11

Step 1: Prepare and Install the Ceiling

- Drill a 16.93 inch x 51.18 inch (430 mm x 1,300 mm) hole into the ceiling based on the layout of the installation board. The center of the ceiling opening should match the center of the indoor unit's body.
Note: In order to keep the ceiling level and prevent vibrations, reinforce the strength of the ceiling when necessary.
- After the ceiling is cut, remove the installation board, then install the ceiling.

Step 2: Panel Installation

Model A

Note:

The air grille received by the customer is not tightened by the wire rope, but is specifically designed to be loose for easy installation.

- Grab the air grille with your fingers and pull it out slowly in the direction of the arrow.

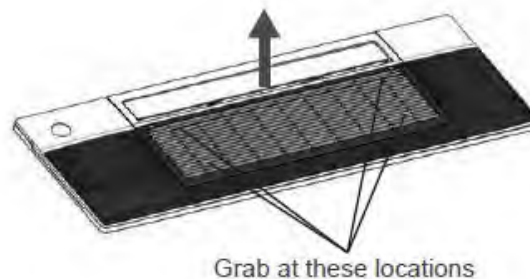

- Pull the panel grille out of the panel, then fix the cassette panel to the one-way cassette with two plastic buckles.

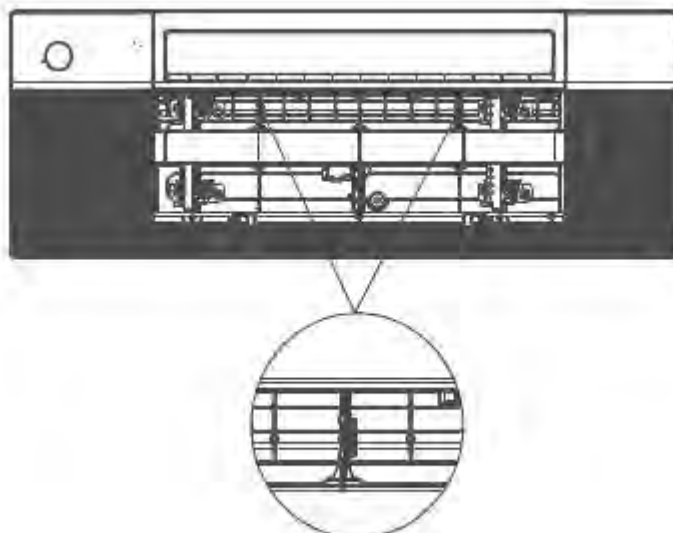

Panel Installation

11

- Manually rotate the air deflector, then fix the panel to the cassette by using three M4*22 screws and a ST3.9*16 screw.

Note:

Eight M4*22 are supplied, two of which are spare.
Two ST3.9*16 screws are supplied, one of which is a spare

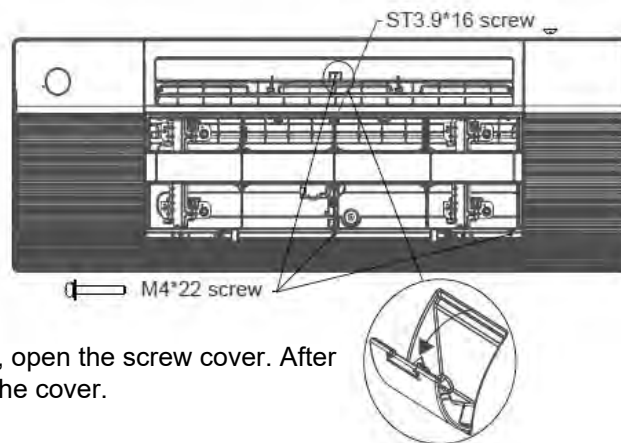

Before fixing this screw, open the screw cover. After fixing the screw, close the cover.

- Open the two covers on both sides of the panel. After, fix the panel to the cassette by using three M4*22 screws.

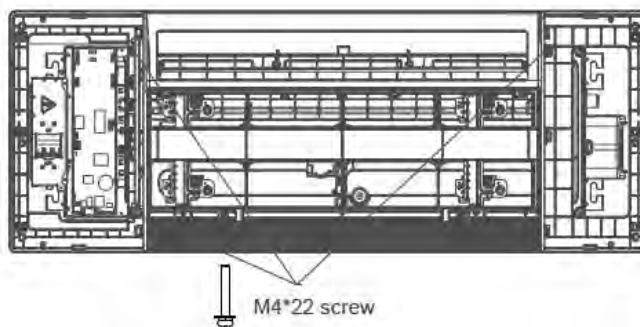

- Connect the display board to the main control board. Four wires are required for connection.

Note:

The corresponding colors or pins are connected to each other.

Panel Installation

11

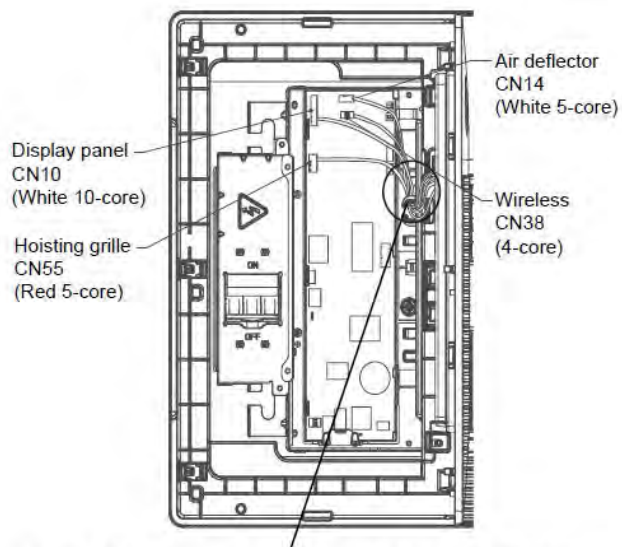

When the connection is completed, clip the wires to the buckle

- Install the control box cover and turn on the circuit breaker. Then, close the two plastic covers on both sides of the panel.

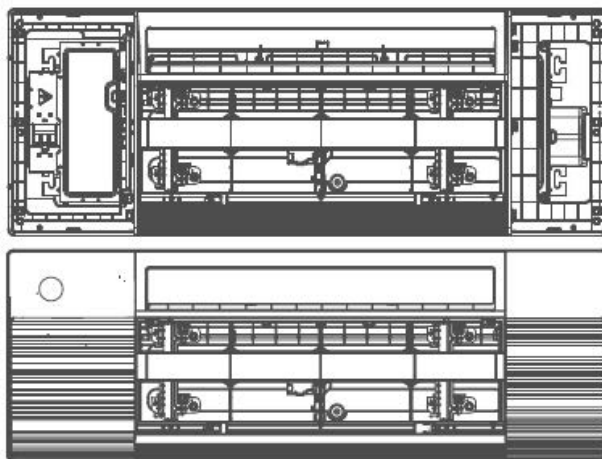

- During the test-run process, the display will light up and the air grille will rise automatically.



Panel Installation

11

Model B

- Press the circular position to open the two screw covers, then remove the two screws.

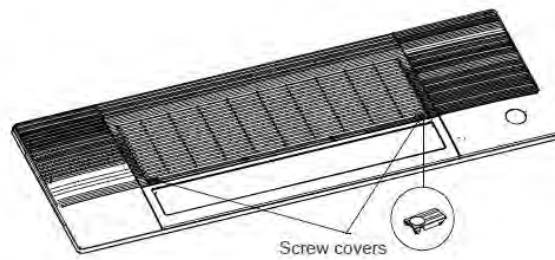

- Hold and open the air grille, then push both of the latches to the middle to unlock the air grille.

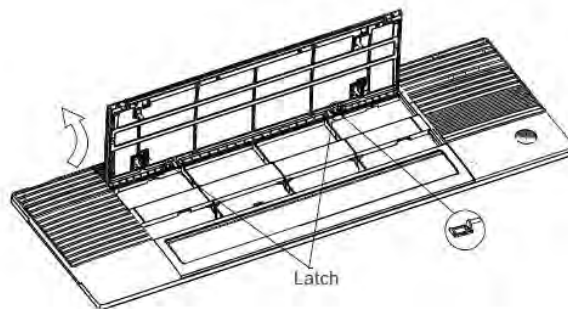

- Pull the panel grille out of the panel. After, fix the cassette panel to the one-way cassette using two plastic buckles.

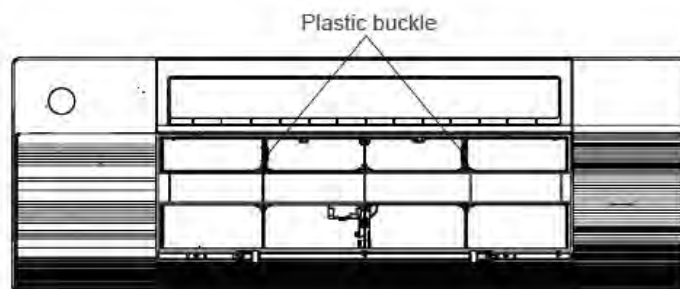

Panel Installation

11

- Manually rotate the air deflector, then fix the panel to the cassette by using three M4*22 screws and a ST3.9*16 screw.

Note:

Eight M4*22 are supplied, two of which are spare.
Two ST3.9*16 screws are supplied, one of which is a spare

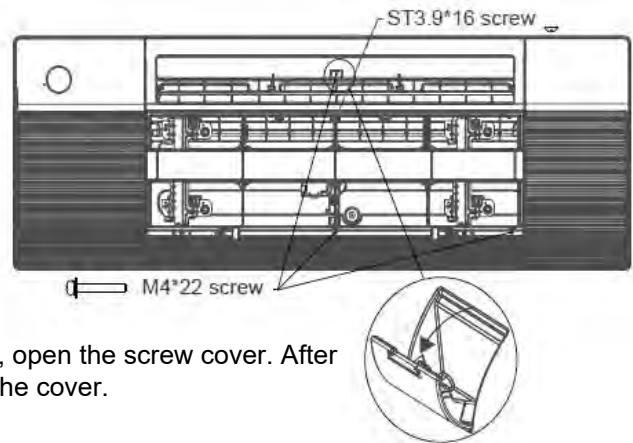

Before fixing this screw, open the screw cover. After fixing the screw, close the cover.

- Open the two covers on both sides of the panel. Then, fix the panel to the cassette using three M4*22 screws.

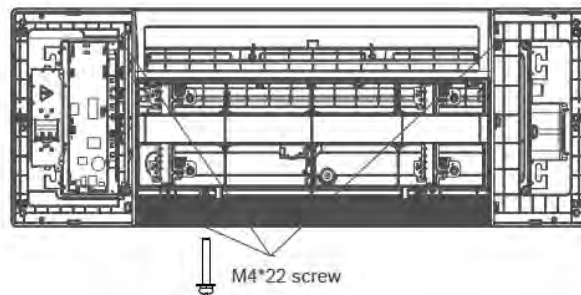

- Connect the display board to the main control board. Up to four wires are required for the connection.

Note:

The corresponding colors or pins are connected to each other.

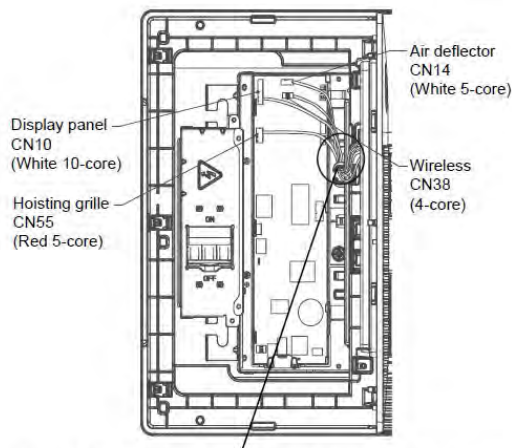

When the connection is completed, clip the wires to the buckle

Panel Installation

11

- Install the control box cover and turn on the circuit breaker. Then, close the two plastic covers on both sides of the panel.

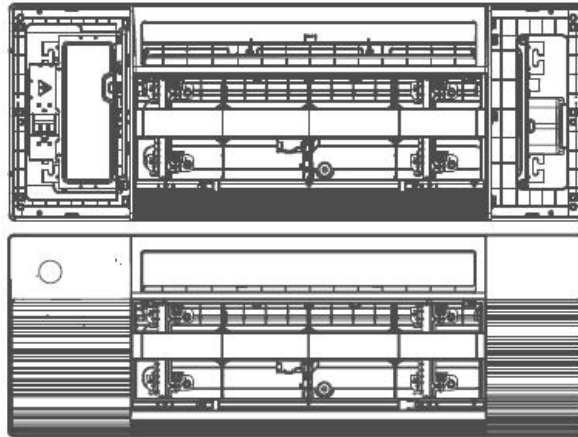

- Reinstall the air grille by pushing the latch to lock it and fixing the two screws. Then, close the two screw covers.

Step 3: Optional Parts Installation

Wireless Module

The wireless module is also named Smart Kit. If this configuration is selected, follow these steps for proper installation.

Note: It is recommended to install this wireless module during the panel installation.

- Remove the protective cap of the wireless module (smart kit).

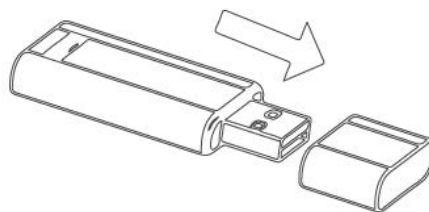

Panel Installation

11

- Open the cover of the display panel, then loosen the screw and remove the cover.



Loosen the screw and remove the cover

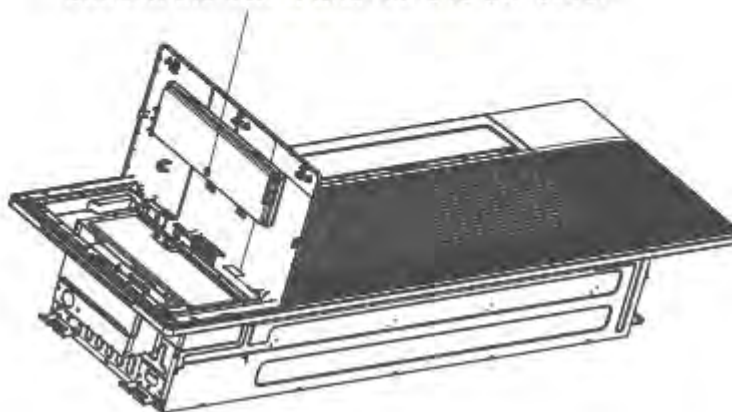

Test Run

12

CAUTION

Failure to perform the test run may result in unit damage, property damage, or personal injury.

Before Test Run

Perform the test run after the entire system has been completely installed. Confirm the following points before performing the test:

- a) The indoor and outdoor units are properly installed.
- b) The piping and wiring are properly connected.
- c) There are no obstacles near the inlet and outlet of the unit that might cause poor performance or product malfunction.
- d) The refrigeration system does not leak.
- e) The drainage system is unimpeded and draining to a safe location.
- f) The heating insulation is properly installed.
- g) The grounding wires are properly connected.
- h) The length of the piping and additional refrigerant capacity have been recorded.
- i) The power voltage is the correct voltage for the air conditioner.

Test Run Instructions

1. Open both the liquid and gas stop valves.
2. Turn on the main power switch and allow the unit to warm up.
3. Set the air conditioner to Cool mode.
4. For the indoor unit:
 - a) Ensure that the remote control and its buttons operate properly.
 - b) Ensure that the louvers move properly and can be changed using the remote control.
 - c) Double check to see if the room temperature is being registered correctly.
 - d) Ensure that the indicators on the remote control and display panel for the indoor unit operate properly.
 - e) Ensure that the manual buttons on the indoor unit operate properly.
 - f) Confirm that the drainage system is unimpeded and draining smoothly.
 - g) Ensure that there is no vibration or abnormal noise during operation.

Test Run

12

Note: If the unit malfunctions or does not operate according to your expectations, refer to the Troubleshooting section before calling customer service.

Water Discharge Test

- Before the test, make sure that the water discharge pipeline is smooth. In addition, check that each connection is sealed properly.
 - Conduct the water discharge test in the new room before the ceiling is paved.
1. Connect the power supply and set the air conditioner to operate in Cool mode. Check the running sound of the drainage pipe.
 2. Allow Cool mode to run for at least 10 minutes.
 3. Stop the air conditioner. Wait for three minutes and then check if there is anything unusual. If the water discharge piping layout is incorrect, the excessive water flow will cause the water level error and the "EE" error code will appear on the display panel. There may even be water overflowing from the water pan.
 4. Continue to add water until the alarm for the excessive water levels is triggered. Check if the drainage pump drains the water immediately. After three minutes, if the water level does not fall below the warning line, the unit will shut down. At this time, turn off the power supply and drain away the accumulated water before turning on the unit normally.
 5. Turn off the power supply, remove the water manually using the drainage pipe, and put the test cap back to the original place.

CAUTION

The drainage plug at the bottom of the unit body is used to discharge the accumulated water from the drain pan when the air conditioner malfunctions. When the air conditioner is operating normally, make sure the drainage plug is properly set up to prevent water from leaking.

Unpacking & Packing

13

Instructions for unpacking and packing the unit:

Unpacking:

Indoor Unit:

1. Cut the sealing tape on the carton with a knife (one cut on the left, one cut in the middle, and one cut on the right).
2. Use the vice to take out the sealing nails on the top of the carton.
3. Open the carton.
4. Take out the middle support plate if it is included.
5. Remove the accessory package, and take out the connecting wire if it is included.
6. Lift the machine out of the carton and lay it flat.
7. Remove the left and right packaging foam or the upper and lower packaging foam. Untie the packaging bag.

Outdoor Unit:

1. Cut the packing belt.
2. Take the unit out of the carton.
3. Remove the foam from the unit.
4. Remove the packing bag from the unit.

Packing:

Indoor Unit:

1. Put the indoor unit into the packing bag.
2. Attach the left and right packaging foam or the upper and lower packaging foam to the unit.
3. Put the indoor unit into the carton, then put the accessory package inside.
4. Close the carton and seal it.
5. Use the packing belt if necessary.

Outdoor Unit:

1. Put the outdoor unit into the packing film.
2. Put the bottom foam into the box.
3. Put the outdoor unit into the carton, then put the upper packaging foam on the unit.
4. Close the carton and seal it with the tape.
5. Use the packing belt if necessary.

Note: Keep all the packaging items in case they're needed in the future.

Operation Instructions

14

Note

To further optimize the unit's performance, do the following:

- Keep doors and windows closed.
- Limit energy usage by using the Timer On and Timer Off functions.
- Do not block air inlets or outlets.
- Regularly inspect and clean air filters.

Indoor Unit Display

There is one type of display panel. The display panel's appearance is shown below:

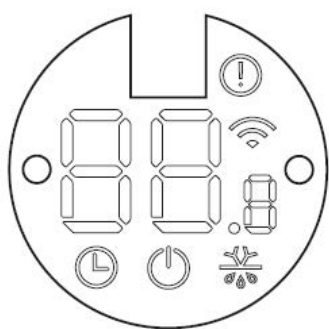

- "⌚" When the Timer is set.
- "⏻" When the unit is on.
- "!⚠️" Alarm indicator.
- "📶" When the Wireless Control feature is activated.
- "❄️" When the preheating/defrost feature is activated.
- "88.8" Displays temperature, operation feature, and error codes.
- "FP" When the 4°F/8°C heating feature is turned on.
- "[L]" When the Active Clean feature is turned on.
- "AP" When the wireless module enters AP mode.
- "FC" When the Forced Cooling feature is turned on.

Features

Note

Each time the air conditioner is powered on, a buzzing sound will be heard to indicate that the product has been powered on normally. If there is no sound, it is possible that the unit is operating abnormally. Power on the unit again or check the circuit.

The actual functions are subject to the product that was purchased. Check the indoor display and remote control of the air conditioner. See the Remote Controller manual for information on more features.

• Default Setting

When the air conditioner restarts after a power failure, it will default to the factory settings (Auto mode, Auto fan, 76°F (24°C)). A power failure may cause inconsistencies on the remote control and panel. Use the remote control to update the status.

• Auto-Restart

If a power failure occurs, the system will immediately stop. When power returns, the operation light on the indoor unit will flash. Press the On/Off button on the remote control to restart the unit. If the system has an auto-restart function, the unit will restart using the same settings.

• 3-Minute Protection Feature

A protection feature prevents the air conditioner from activating for approximately 3 minutes when it restarts immediately after operation.

• Louver Angle Memory Function

Note: Only available for units with the louver angle memory function.

When the unit restarts after a power failure, the angle of the horizontal louvers will automatically return to the previous position. The angle of the horizontal louver must not be set too small, as condensation may form and drip into the machine. To reset the louver, press the manual button, which will reset the horizontal louver settings.

Operation Instructions

14

• Sleep Operation

The Sleep function decreases energy use during sleeping hours. The function doesn't need the same temperature settings to stay comfortable. Use the remote control to activate this function. The Sleep function is not available in Fan or Dry mode.

Press the Sleep button to activate this function. When in Cool mode, the unit will increase the temperature by 2°F (1°C) after 1 hour, then increase by an additional 2°F (1°C) after another hour. When in Heat mode, the unit will decrease the temperature by 2°F (1°C) after 1 hour, then decrease by an additional 2°F (1°C) after another hour.

The Sleep feature will stop after 8 hours and the system will keep running with the final situation.

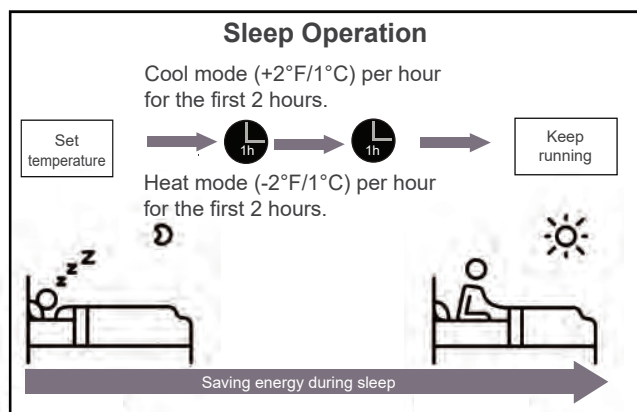

• Active Clean Function (Multi-zone system models do not have this function)

The Active Clean technology washes away dust when it adheres to the heat exchanger by automatically freezing and then rapidly thawing the frost. A "pi-pi" sound will be heard. The Active Clean operation is used to produce more condensed water to improve the cleaning effect. Cold air will blow out. After cleaning, the internal wind wheel will continue operating with hot air to blow-dry the evaporator, thus keeping the inside clean.

• Heat Exchanger Dust Removal Function

This feature helps keep the outdoor coil cleaner and may extend the duration between regular maintenance intervals depending on the local conditions. When the unit is turned off, a 10-second delay occurs when the outdoor fan runs in reverse rotation for 70 seconds to blow off loose accumulated dust and debris.

• Refrigerant Leakage Detection

When the system detects a refrigerant malfunction, the indoor unit will automatically display the following error codes:

- EL0C - System lacks refrigerant.
- EHC1 - Refrigerant sensor detects leakage.
- EHC2 - Working condition of the refrigerant sensor is out of range and leakage is detected.
- EHC3 - Working condition of the refrigerant sensor is out of range.
- ECC1 - Other indoor unit refrigerant sensor detects leakage (multi-zone systems).

When "EHC1" or "EHC2" errors occur, the buzzer will continue to beep for 5-6 minutes before stopping. Pressing any button on the remote control will also stop the buzzer.

Note: "EHC1", "EHC2", "EHC3", and "ECC1" error codes are only applicable for units with refrigerant sensors.

• Lifting Panel Operation

In Standby-By mode, press the "Mode" and "Down" buttons simultaneously for 3 seconds to have the remote control enter the setting panel state and display the "F2" code. When setting the panel status, press the "Up" and "Down" buttons on the remote control to control the rise or fall of the grille. Press any other button to exit the setting. The up and down height of the panel can reach a maximum of 4.9 feet (1.5 m). During the decline, if the grill is raised by the obstacles, it will stop. During the ascending process, if the grille is blocked and does not rise to the correct height or a finger is pinched, it will automatically descend after a period of time and then ascend. If the grille is blocked three times, the display panel will report an error and prompt the manual processing.

Operation Instructions

14

Breeze Away

This feature prevents direct air flow from blowing on the body, making the user feel as though they are indulging in silky coolness.

Energy Saving Tips

- Do not set the unit to excessive temperature levels.
- While cooling, close the curtains to avoid direct sunlight.
- Close doors and windows to keep cool or warm air in the room.
- Do not place objects near the air inlet and outlet of the unit.
- Clean the air filter every two weeks.
- Properly adjust louvers and avoid direct airflow.
- Closing curtains during Heating mode also keeps the heat in.

Care & Maintenance

15



Before Cleaning or Maintenance

Remember to disconnect the power before cleaning or performing maintenance, except for cleaning the air filter. Turning off the indoor unit's circuit breaker is not a kind of power disconnection.

- Contact an authorized service technician for repairs or maintenance. Improper repairs or maintenance may cause water leakage, electrical shock, or fire. It may also void your warranty.
- Do not substitute a blown fuse with a higher or lower amperage rating fuse, as this may cause circuit damage or an electrical fire.
- Make sure the drain hose is set up according to the instructions. Failure to do so could cause leakage and result in personal property damage, fire, and electrical shock.
- Make sure that all wires are connected properly. Failure to connect the wires according to the instructions can result in electrical shock or fire.



CAUTION

- Only use a soft, dry cloth to wipe the unit clean. If the unit is especially dirty, use a cloth soaked in warm water to wipe it clean.
- Do not use chemicals or chemically treated cloths to clean the unit.
- Do not use benzene, paint thinner, polishing powder, or other solvents to clean the unit. They can cause the plastic surface to crack or deform.
- Do not use water hotter than 104°F (40°C) to clean the front panel. This can cause the panel to deform or become discolored.
- Do not wash the unit under running water. Doing so creates an electrical hazard. Use a damp, lint-free cloth and neutral detergent to clean the unit. Dry the unit with a dry, lint-free cloth.



WARNING: DO NOT REMOVE OR CLEAN THE FILTER BY YOURSELF

Removing and cleaning the filter can be dangerous. A certified technician must perform the removal and maintenance.

Clean the Indoor Unit (Air Filter)

The filter prevents dust and other particles from entering the indoor unit. Dust buildup can reduce the efficiency of the air conditioner. For optimum efficiency, clean the air filter every two weeks or more frequently if the unit is in a dusty area. Replace the filter with a new one if it's heavily clogged and cannot be cleaned.

Note: In households with animals, periodically wipe down the grille to prevent animal hair from blocking the airflow.

Care & Maintenance

15

Model A

1. In Stand-By mode, press the "Mode" and "Down" buttons simultaneously on the remote control for 3 seconds. The remote control enters the panel-setting state and displays the "F2" code.

2. Press the "Down" button on the remote control, allowing the air grille to automatically go down. When it stops, pick up the air filter.

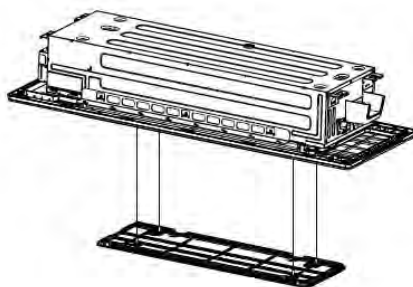

- Hold the upper edge of the filter with both hands. Gently turn and lift until the upper edge is free from the wire rope.
- Lift the filter and move it forward slightly until the filter is separated from the four wire ropes.
- Move the filter to the right until it is separated from the air grille, then the filter can be taken out.

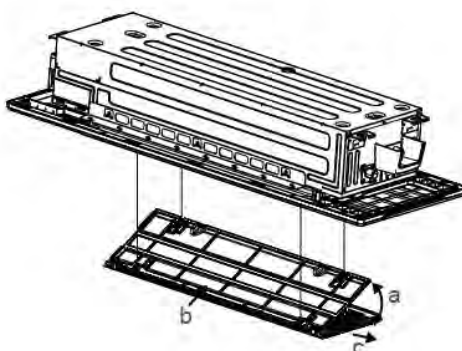

Care & Maintenance

15

Model B

1. Press the circular position to open the screw covers, then remove the two screws.

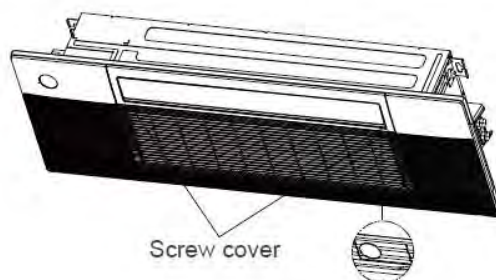

2. Hold and open the air grille, then take out the air filter.

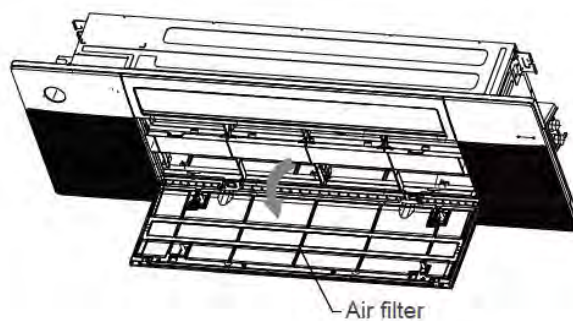

3. Clean the air filter.

Dust will accumulate on the filter during operation. Remove the dust from the filter, so the unit functions effectively. Clean the filter every two weeks when the unit is frequently used. Clean the air filter with a vacuum cleaner or water.

- a. Ensure that the air intake side is facing up when using a vacuum cleaner.

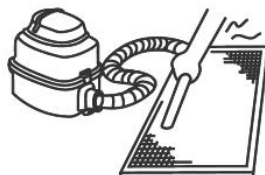

- b. Ensure that the air intake side is facing down when using clean water.



Care & Maintenance

15

4. Reinstall the air filter.

5. Press the "Up" button on the remote control to reset the air grille. (Applicable to Model A)

Reinstall the air grille by fixing the two screws. Then, close the two screw covers. (Applicable to Model B)

⚠ CAUTION

- Before changing or cleaning the filter, turn off the unit and disconnect its power supply.
- When removing the filter, do not touch metal parts in the unit. The sharp metal edges can cut you.
- Do not use water to clean the inside of the indoor unit. This can destroy insulation and cause electrical shock.
- Do not expose to direct sunlight when drying. This can shrink the filter.
- An authorized dealer or licensed service provider must perform any maintenance and clean the outdoor unit.
- An authorized dealer or licensed service provider must perform any unit repairs.
- Install the air filter before installing the unit body.

Maintain the AC

Maintenance - Long Periods of Non-Use

If the air conditioner won't be used for an extended period of time.



Clean all filters



Turn on the Fan function until the unit dries out completely



Turn off the unit and disconnect the power

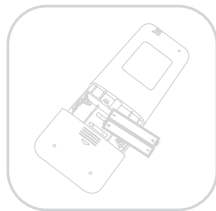

Remove the batteries from the remote control

Maintenance - Pre-Season Inspection

After long periods of non-use or before periods of frequent use, do the following:

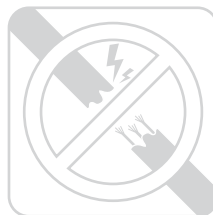

Check for damaged wires

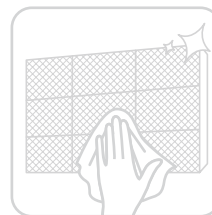

Clean all filters



Check for leaks

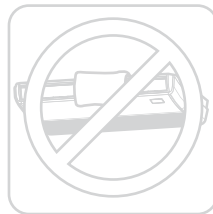

Make sure nothing is blocking the air inlets and outlets

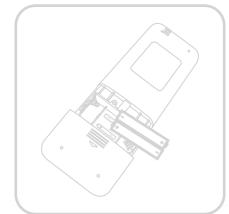
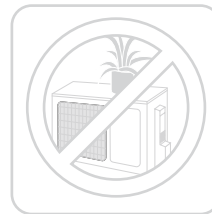

Replace the batteries



Troubleshooting

T

⚠ CAUTION

If any of the following conditions occur, turn off the unit immediately:

- The power cord is damaged or abnormally warm.
- A burning odor is present.
- The unit is emitting loud or abnormal sounds.
- A power fuse blows or the circuit breaker frequently trips.
- Water or other objects fall into or out of the unit.

Do not attempt to fix these problems by yourself. Contact an authorized service provider immediately.

Common Issues

The following issues are not malfunctions and will not require repairs in most situations:

Issue	Possible Causes
Unit does not turn on when pressing the On/Off button	The unit has a 3-minute protection feature that prevents the unit from overloading. The unit cannot be restarted within 3 minutes of being turned off.
	Cooling and Heating mode: If the operation light and PRE-DEF (pre-heating/defrost) indicators are lit up, the outdoor temperature is too cold, activating the unit's anti-cold wind feature in order to defrost the unit.
	In Cooling-only mode: If the Fan-Only indicator is lit up, the outdoor temperature is too cold, activating the unit's anti-freeze protection in order to defrost the unit.
Unit changes from Cooling/Heating mode to Fan mode	The unit may change its settings to prevent frost from forming on the unit. Once the temperature increases, the unit will start operating in the previously selected mode again.
	The set temperature has been reached, at which point the unit turns off the compressor. The unit will continue operating when the temperature fluctuates again.
Indoor unit emits white mist	In humid regions, a large temperature difference between the room's air and the conditioned air can cause white mist.
Indoor and outdoor units emit white mist	When the unit restarts in Heating mode after defrosting, white mist may be emitted due to moisture generated from the defrosting process.
Indoor unit makes noises	A rushing air sound may occur when the louver resets its position.
	A squeaking sound is heard when the system is off or in Cooling mode. The noise is also heard when the drain pump (optional) is in operation.
	A squeaking sound may occur after running the unit in Heating mode, due to expansion and contraction of the unit's plastic parts.
Indoor and outdoor units make noises	Low hissing sound during operation: This is normal and caused by refrigerant gas flowing through both the indoor and outdoor units.
	Low hissing sound when the system starts, stops running, or defrosting: This noise is normal and caused by the refrigerant gas stopping or changing direction.
	Squeaking sound: Normal expansion and contraction of plastic and metal parts caused by temperature changes during operation can cause squeaking noises.

Troubleshooting

T

Issue	Possible Causes
Outdoor unit makes noises	The outdoor unit will make different sounds based on its current operating mode.
Dust is emitting from either the indoor or outdoor unit	The unit may accumulate dust during extended periods of non-use, which will be emitted when the unit is turned on. This can be mitigated by covering the unit during long periods of inactivity.
Unit emitting bad odor	The unit may absorb odors from the environment, which will be emitted during operations. Examples are furniture, cooking, cigarettes, etc.
	The unit's filters have become moldy and need to be cleaned.
Fan of the outdoor unit does not operate	During operation, the fan speed is controlled to optimize product operation.

Note: If the problem persists, contact a local dealer or the nearest customer service center. Provide them with a detailed description of the unit malfunction and model number.

When trouble occurs, check the following points before contacting a repair company:

Problem	Possible Causes	Solution
Poor Cooling Performance	Temperature setting may be higher than ambient room temperature.	Lower the temperature setting.
	Heat exchanger on the indoor or outdoor unit is dirty.	Clean the affected heat exchanger.
	Air filter is dirty.	Remove the filter and clean it according to the instructions in this manual.
	Air inlet or outlet of either unit is blocked.	Turn the unit off, remove the obstruction, and turn it back on.
	Doors and windows are open.	Make sure that all doors and windows are closed while operating the unit.
	Excessive heat is generated by sunlight.	Close windows and curtains during periods of high heat or bright sunshine.
	Too many sources of heat in the room (people, computers, electronics, etc.).	Reduce the amount of heat sources.
	Low refrigerant due to leak or long-term use.	Check for leaks. Reseal if necessary and top off the refrigerant.

Troubleshooting

T

Problem	Possible Causes	Solution
Unit is not working	Power failure.	Wait for the power to be restored.
	Power is turned off.	Turn on the power.
	Fuse is burned out.	Replace the fuse.
	Remote control batteries are dead.	Replace the batteries.
	The unit's 3-minute protection has been activated.	Wait 3 minutes after restarting the unit.
	The unit's timer is activated.	Turn the timer off.
Unit starts and stops frequently	There's too much or little refrigerant in the system.	Check for leaks and recharge the system with refrigerant.
	Incompressible gas or moisture has entered the system.	Evacuate and recharge the system with refrigerant.
	System circuit is blocked.	Determine which circuit is blocked and replace the malfunctioning piece of equipment.
	Compressor is broken.	Replace the compressor.
	Voltage is too high or low.	Install a manostat to regulate the voltage.
Poor heating performance	Outdoor temperature is extremely low.	Use an auxiliary heating device.
	Cold air is entering through doors and windows.	Make sure that all doors and windows are closed during use.
	Low refrigerant due to leak or long-term use.	Check for leaks. Reseal if necessary and top off refrigerant.

Indicator lamps continue to flash

Error codes appear and begin with the letters as the following in the window display of the indoor unit:

- E (x), P (x), F (x)
- EH (xx), EL (xx), EC (xx)
- PH (xx), PL (xx), PC (xx)

The unit may stop operation or continue to run safely. If the indicator lamps continue to flash or error codes appear, wait about 10 minutes. The problem may resolve itself.

If not, disconnect the power. Then, connect the power again and turn the unit on.

Note: If the problem continues after performing the checks and diagnostics above, turn off the unit immediately and contact an authorized service center.

The design and specifications are subject to change without prior notice for product improvements. Consult with the sales agency or manufacturer for details. Any updates to the manual will be uploaded to the service website, check for the latest version.

The design and specifications of this product are subject to change without prior notice as development continues. Consult with the sales agency or manufacturer for details. Refer to the equipment nameplate for all other applicable specifications.



is a registered trademark of Parker Davis HVAC International, LLC.

Parker Davis HVAC International
7290 NW 77 Court, Miami, FL 33166 - USA
Tel : (305) 513-4488
Fax : (305) 513-4499
E-mail : info@pdhvac.com
Website: www.pdhvac.com

Pioneer product line, parts, and supplies are available online for convenient ordering at:
www.highseer.com
www.pioneerminisplit.com

Scan the below code to visit our support page where you can find more installation materials:

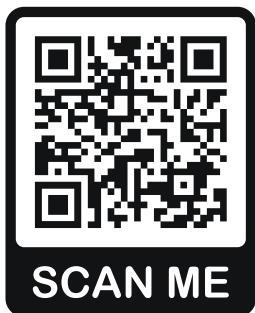

Copyright © Parker Davis HVAC International, LLC. All rights reserved.
