

# ***INSTRUCTIONS MANUAL***

***model***

***STAR 55***  
***2001***

# CONTENTS

## 1 FUNCTIONAL DESCRIPTION OF THE SYSTEM

1.1	FOREWORD .....	4
1.2	DESCRIPTION OF THE SYSTEM OPERATION .....	4
1.2.1	<i>THERMODYNAMIC CYCLE</i> .....	4
1.2.2	<i>STARTING PHASE</i> .....	4
1.2.3	<i>COOLING PHASE, TEMPERATURE ADJUSTMENT</i> .....	4
1.2.4	<i>DEFROSTING PHASE</i> .....	5
1.2.5	<i>OTHER FUNCTIONS</i> .....	5
1.3	DESCRIPTION OF THE ELECTRIC SYSTEM .....	6
1.3.1	<i>SYSTEM POWER SUPPLY</i> .....	6
1.3.2	<i>ELECTRICAL DEVICES</i> .....	7
1.3.3	<i>LIGHTING SYSTEM</i> .....	8
1.3.4	<i>DOOR ANTICONDENSING SYSTEM</i> .....	8

## 2 STRUCTURAL DESCRIPTION OF THE SYSTEM

2.1	EXTERNAL APPEARANCE .....	10
2.2	USER'S CONTROLS .....	11
2.3	MECHANICAL AND ELECTRICAL COMPONENT PARTS IN THE TANK .....	12
2.4	MECHANICAL AND ELECTRICAL PARTS IN THE COMPRESSOR COMPARTMENT .....	14
2.5	MECHANICAL AND ELECTRICAL COMPONENT PARTS AT THE BACK OF THE CABINET .....	16
2.6	ELECTRICAL COMPONENTS IN THE DISPLAY COMPARTMENT .....	18

## 3 BASIC RULES FOR THE CORRECT OPERATION

3.1	START UP INSTRUCTIONS .....	20
3.2	BASIC SAFETY RULES .....	21
3.3	RULES TO IMPROVE THE EFFICIENCY OF THE SYSTEM .....	22

## 4 MAINTENANCE INTRUCTIONS

4.1	MAINTENANCE OF THE CABINET .....	24
4.1.1	<i>DOOR REPLACING</i> .....	24
4.2	MAINTENANCE IN THE TANK .....	25
4.2.1	<i>NEON TUBES REPLACING</i> .....	25
4.2.2	<i>EVAPORATOR MOTOR FAN REPLACING</i> .....	26
4.2.3	<i>EVAPORATOR HEATER REPLACING</i> .....	27
4.2.4	<i>EVAPORATOR GUTTER DRAINING TUBE HEATER REPLACING</i> .....	27
4.2.5	<i>END-OF DEFROSTING THERMOSTAT REPLACING</i> .....	28
4.2.6	<i>EVAPORATOR REPLACING</i> .....	29
4.3	MAINTENANCE IN THE COMPRESSOR COMPARTMENT .....	30
4.3.1	<i>CONDENSER MOTOR FAN REPLACING</i> .....	30
4.3.2	<i>LOW PRESSURE THERMOSTAT REPLACING</i> .....	30
4.3.3	<i>TANK THERMOSTAT REPLACING</i> .....	31

## 5 UTILITY

5.1	FUNCTIONAL WIRING DIAGRAM .....	33
5.2	SPARE PARTS LIST .....	35

# **1 FUNCTIONAL DESCRIPTION OF THE SYSTEM**

## 1.1 FOREWORD.

The Star 55 model is a vertical ventilated cooling display cabinet at negative temperature and it is suitable for preserving ice-creams and frozen food at the temperature of  $-18^{\circ}\text{C}$  ( $-0.4^{\circ}\text{F}$ ). Thanks to the internal ventilation system, this machine performs automatically periodical defrostings of the evaporator and therefore, it does not need maintenance.

The defrosting system, operated by means of an electrical heater, guarantees best performances with low current consumption.

A system consisting of two neon tubes positioned in the inner tank, lights the product preserved internally, by enhancing its characteristics.

An illuminated display, at the top of the cabinet, highlights the brand name.

## 1.2 DESCRIPTION OF THE SYSTEM OPERATION

Picture 1 is showing the exploded drawing of the refrigerator. In the following description every component will be identified by its number on the exploded drawing and by its code on the wiring diagram at section 5.1.

### 1.2.1 THERMODYNAMIC CYCLE

The refrigerating cycle used by Star 55 is by gas compression. Here are the main components, described on the exploded drawing and on the wiring diagrams SE0211/06 on section 5.1:

- Compressor (CO) (12);
- Condenser (14) with relative motor fan (MC) (38) and blade (41);
- Dryer (21);
- Refrigerant flow (cut off) valve (VM) (84) with solenoid coil (2);
- Capillary tube;
- Evaporator (20) with relative motor fan (MI) (39) and blade (40);
- Liquid splitter with heat exchanger.

The refrigerant used is R404a, CFC and HCFC free.

### 1.2.2 STARTING PHASE

To protect the compressor (CO) (10) from heat overloads during the phase following the refrigerator start-up, the operation of the internal motor fan (MI) (39) is delayed by a fixed calibration thermostat (KFS) (5) positioned on the evaporator, whose function is also that of limiting temperature during the defrosting phase; therefore, before the operation of the inside motor fan, it is necessary that the evaporator lowers its temperature until the thermostat (KFS) (5) starts the internal motor fan. This operation could take about fifteen minutes.

### 1.2.3 COOLING PHASE: TEMPERATURE ADJUSTMENT

The internal temperature adjustment is made by an adjustable thermostat (TC) (80), positioned on the front control panel (18), that acts on the cut-off valve (VM) (84) solenoid coil (2): this valve has the function to trap the refrigerant in the condenser, by closing the access to the capillary tube and stopping the refrigerant flow to the evaporator. When the internal temperature reaches the desired value, set by the thermostat, the cut-off valve closes and the compressor reduces the evaporator pressure, till the low pressure control pressostat (PBP) (88) stops it and contemporary the condenser motor fan (MC) (38)

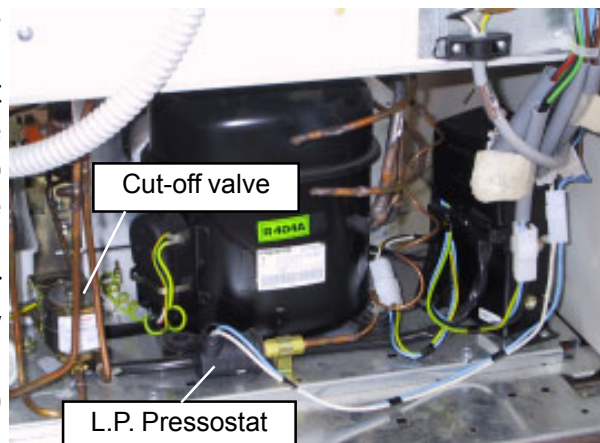

wired in parallel on the compressor; thus the internal temperature rises, and when it reaches the value correspondent to the thermostat differential, the thermostat itself acts again on the cut off valve solenoid coil, opening the valve: the refrigerant can flow to the evaporator making its pressure rising, till the low pressure pressostat turns again the compressor and the condenser motor fan on. This function is called "pump down" cycle. The length of the standby period depends on the ambient temperature and on the quantity of product preserved inside the machine.

The tank thermostat (TC) (80) has 7 adjustment positions, from 1 to 7: the higher the number is, the colder the tank temperature is.

#### **1.2.4 DEFROSTING PHASE**

When the refrigerator is in operation, every time the door is opened to take some product, humidity contained in the atmospheric air deposits on the evaporator, jeopardizing its efficiency. To solve this problem, an automatic system is provided, which defrosts the evaporator (20) by supplying heat and drains the resulting water into the plastic tray (85) positioned in the compressor seat, where it is evaporated. The activation of the defrosting system, happening periodically every 6 hours, is controlled by a timer (TS) (81) and takes a predefined time of 22.5 minutes max.: during the standby period of 22.5 minutes the heat is supplied to the evaporator by means of an electrical heater (evaporator heater) (REV) (66), and is controlled by the end-of-defrosting thermostat (KFS) (5), positioned on the evaporator (20), reducing it to the minimum possible; in the meantime the internal motor fan (MI) (39), stops, and the cut-off valve (VM) (84), governing the refrigerant flow to the evaporator, locks the refrigerant inside the condenser, while the compressor (CO) (12) and the condenser motorfan (MC) (38) continue to run, reducing the evaporator pressure till the low pressure pressostat (PBP) (88) stops them.

To avoid ice forming on the evaporator draining tube (7), an electrical heater (gutter heater) (RSG) (65) provides to maintains it warm, so that the resulting water can flows away from the inner tank directly into the water tray (85), where a stainless steel pipe (58), connected to the compressor outlet pipe, helps it to evaporate.

#### **1.2.5 OTHER FUNCTIONS**

To avoid an excessive loss of cold during the door opening, a proximity door switch (IP) (36) has been inserted to stop the internal motor fan (MI) (39): every time the door is opened, the inside ventilator stops, reducing the hot air input inside the machine.

An always active wire-wound resistor (RT) (64), located inside the door frame, prevents the door frame itself from condensation.

The door external flat glass surface is electrically heated (RV) to avoid glass condensation and accelerate glass defogging every time the door is opened.

Both these door heaters are electrically supplied by an isolation transformer (TI) (82).

A green lighting main switch (IG) (31) disconnects the freezer from voltage supply by means of a main relay (RG) (63).

By means of the lamps switch (IL) (32) the inner lamps and the display lamp can be switched on and off; this lamps switch has also the function to light when the defrosting phase is active, to inform the user about the state of the freezer.

An EMC (Electro-Magnetic Compatibility) filter (FRF) (22) avoids any electrical noise emission on the voltage supply net.

### **1.3 DESCRIPTION OF THE ELECTRIC SYSTEM**

The wiring diagram SE211/06 of Star 55 2001 is visible in the section 5.1: refer to this diagram during the following descriptions.

The electrical wiring (e.w.) of Star 55 2001 can be divided into the following parts:

- e.w. condensing group;
- e.w. evaporating group;
- e.w. inner lights;
- e.w. display light
- e.w. heated door;
- e.w. controls front panel;
- e.w. devices rear support.

The e.w. condensing group is located in the compressor opening and gives the electrical supply to the compressor (CO) (12) and its components, to the condenser motor fan (MC) (38), to the door isolation transformer (TI) (82), to the low pressure pressostat (PBP) (88) and to the cut-off valve solenoid coil (VM) (2).

The power supply cord with plug (CS) (10) is directly wired to the strain relief terminal connector (37) and to the main relay (RG) (63) on a metal support plate located on the left side of the compressor opening: in the fig. 18c is shown this support plate and the strain relief "2", together with the main relay "1" (RG) (63).

The e.w. evaporating group is located in the top part of the inner tank, protected by the evaporator plastic cover (8), and gives the electrical supply to the evaporator motor fan (MI) (39), to the end of defrosting thermostat (KFS) (5) and to the evaporator heater (REV) (66). The e.w. inner lights gives the supply to the 2 36W inner lights (L2) (34) by means of two electromagnetic ballast (AT2) (60) and two starters (S2) (73) located in the rear support. The two starters are fixed in place by means of two starter holders (52).

The e.w. display light gives the supply to the 13W display lamp (L1) (33) by means of one electromagnetic ballast (AT1) (59) located in the rear support and one starter (S1) (73) located behind the display lamp and fixed in place by means of one starter holder (52).

The e.w. heated door gives the supply to the door frame heater (RT) (64) and the heated glass surface (RV) by means of the isolation transformer (TI) (82), located in the compressor opening.

The e.w. controls front panel gives the supply to the controls located on the front panel (18), that are: the thermostat (TC) (80), the main switch (IG) (31), the lamps switch (IL) (32) and the defrosting light (LS), located inside the lamps switch.

The e.w. devices rear support gives the supply to the electrical devices located in the back of the cabinet (see fig. 18b) and is made by: one defrosting relay "3" (RS) (61), one compressor relay "1" (RC) (62), one ballast (AT1) (59) for display light "5", two ballasts for inner lights (AT2) (60) "6", one defrosting timer "7" (TS) (81), one terminal junction board "8", one EMC filter "9" (FRF) (22) and 2 starters (S2) (73) for inner lights.

#### **1.3.1 SYSTEM POWER SUPPLY**

A power supply cord, equipped with a 15-Ampere plug, allows to connect the refrigerator to the power supply local net.

A main switch (IG) (31), positioned on the front control panel, enables to energize all electrical components of the refrigerator by means of the main relay (RG) (63): its green light indicates that the system is powered.

For compliance with the directive on electromagnetic compatibility (EMC) a capacity filter (FRF) (22) is supplied.

### 1.3.2 ELECTRICAL DEVICES

The below-described devices belong to three different categories:

- Control devices
- Actuators
- Signalling devices

- Devices that allow the user to control a parameter or to activate a device belong to the first category.

- Devices receiving the electric signal from control devices and allowing the enabling / disabling of actuators belong to the second category.

- The signalling devices inform the user of the state of the appliance.

#### Control devices

- Main switch (IG) (31): enables all the devices, acting on the main relay (RG) (63).

- Light switch (IL) (32): enables the inner lights (L2) (34) and the display light (L1) (33).

- Inner tank thermostat (TC) (80): it allows the user to adjust the internal temperature of the refrigerator for average values, starting and stopping periodically the compressor; acts directly on the cut off valve (VM) (84) solenoid coil (2).

- Defrosting timer (TS) (81): it activates, at fixed intervals of 6 hours, the defrosting function for a period of 22.5 minutes; the user can operate it in order to have a defrosting cycle at a preferred time during the day. The defrosting interval and its length are predefined and cannot be modified by the user. It activates the defrosting relay (RS) (61) and the evaporator gutter heater (RSG) 65); at the same time, it stops the internal fan (MI) (36).

#### Actuators

- Door switch (IP) (36): stops the internal motor fan (MI) (39) every time the door is opened. It is located on the top-left of the door, on the display lamp metal support.

- Main relay (RG) (63): operated directly by the main switch (IG) (31), cuts off the voltage supply to the freezer. It is located on a metal support, together with the cord strain relief (37), in the compressor compartment.

- Compressor relay (RC) (62): operated by the low pressure pressostat (PBP) (88), allows the starting/stopping of the compressor (CO) (12) and of the relative motor fan (MC) (38).

- Defrosting relay (RS) (61): activated by the defrosting timer (TS) (81), acts on the cut off valve (VS) (84) solenoid coil (2); at the same time it activates the evaporator heater (REV) (66).

- Low pressure pressostat (PBP) (88): acts directly on the compressor relay (RC) (62), controlling the starting/stopping of compressor (CO) (12) and relative motor fan (MC) (38); it stops the compressor when the evaporator pressure decreases below a fixed value.

- Compressor (CO) (12): it performs the function of rising the refrigerant pressure to allow the change of state from gas to liquid.

- Condenser motor fan (MC) (38) and blade (41): it enables the change of refrigerant state inside the condenser (14) and performs the refrigerant cooling function.

- Evaporator motor fan (MI) (39) and blade (40): it enables the air circulation inside the tank and allows its cooling in the evaporator (20).

- Cut off valve (VM) (84) and solenoid coil (2): it performs the function of enabling/disabling the refrigerant flow towards the evaporator.

ols panel (18)

- End-of-defrosting thermostat (KFS) (5): it controls the evaporator maximum temperature during defrosting and governs the internal fan delayed-action function. Its working is automatic and cannot be adjusted by the user.
- EMC filter (FRF) (22): suppresses electromagnetic interferences emitted by the electrically networked machine.
- Inner lamps (L2) (34): permit the product illumination.
- Inner lamps ballasts (AT2) (60): performs the function of generating the necessary current to operate the neon inner tubes.
- Inner lamp Starters (S2) (73): performs the function of striking the electric discharge in the lamps gas.
- Display lamp (L1) (33): permits the display illumination.
- Display lamp ballast (AT1) (59): it performs the function of generating the current necessary to operate the neon tube.
- Display lamp Starter (S1) (73): performs the function of striking the electric discharge in the lamps gas.
- Isolation transformer (TI) (82): performs the function to electrically insulate those component parts that cannot be protected by the earth circuit; it powers the heated glass surface (RV) and the door frame heater (RT) (64).

#### Signaling devices

- Analogue thermometer (79): located on the controls panel (18), shows the temperature value inside the refrigerator, both in Celsius and Fahrenheit degrees.
- Defrosting led (LS) (32): it lights on when the defrosting phase is activated; it is red-coloured; it is red-colored and housed inside the lights switch on the controls panel (18).
- Voltage led: it warns on the presence of voltage in the system; it is green-colored and housed inside the main switch (IG) (31), located on the controls panel (18)

### 1.3.3 LIGHTING SYSTEM

The refrigerator is equipped with a lighting system including two T8 26 mm 36 W neon tubes (L2) (34), located inside the tank, and one T5 16 mm 13 W neon tube (L1) (33), located inside the display. The neon tubes are controlled by a push-button switch (IL) (32) positioned on the front panel (18). This push-button switch permits to switch on and off the inner lamps and the display lamp contemporary. The neon tubes are powered by two standard electromagnetic 36W ballasts (AT2) (60) and the display lamp is powered by one 13W ballast (AT1) (59), that work with a 120 V input voltage and generate a 230 V output voltage: therefore the starters, whose function is to strike an electric discharge in the lamps gas, must have a 230V rated voltage. The 3 ballasts and the inner lamps starters are located in the rear devices support; the display lamp starter is located behind the lamp, in the display compartment.

### 1.3.4 DOOR ANTICONDENSING SYSTEM

Two heating elements are located on the door: one, consisting of a wire-wound resistor (RT) (64), heats the door frame, while the other is made of a conductor film (RV) distributed on the internal surface of the external layer of the multiple flat glass. The resistors are connected in parallel by means of a multiple cable joint, going out through the lower door hinge.

The two heating elements are powered by an isolation transformer (TI) (82), protecting them from the risk of electric shocks due to possible malfunctions.

# 2 STRUCTURAL DESCRIPTION OF THE SYSTEM

**FIG.1**

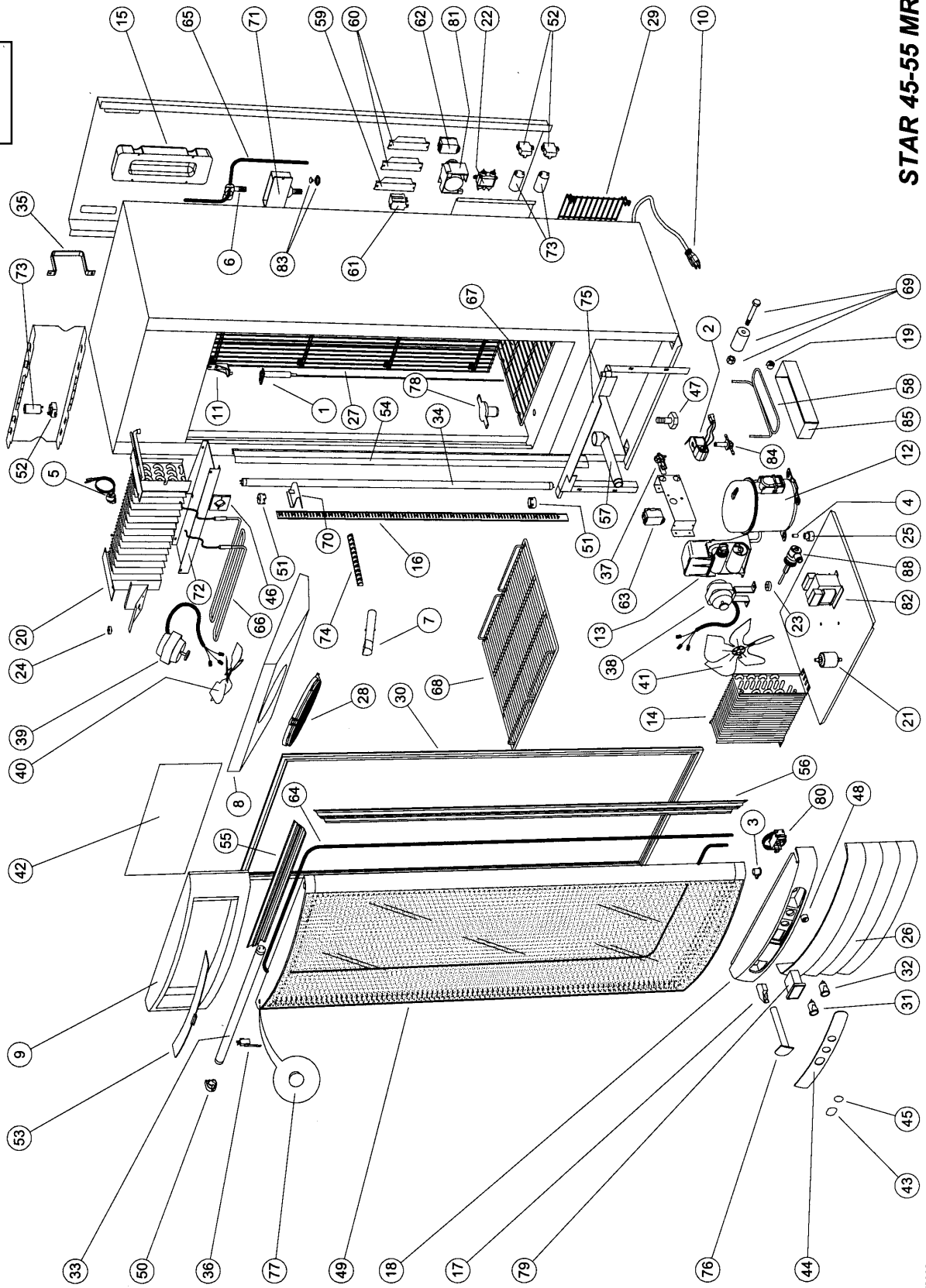

**STAR 45-55 MR**  
Dis. ES206



## 2.1 EXTERNAL APPEARANCE

The outer appearance of the refrigerator is shown in figure 2.

The cabinet consists of an external shell and an internal one in galvanized and plastified sheet; between them insulating material (polyurethane) is introduced.

Starting from the lower part of the appliance you can see the compressor compartment front grill (26), the controls panel (18) with its plastic cover (44), the heated glass door and the illuminated display (9). The hermetic seal of the door is guaranteed by a magnetic gasket (30), hitting the cabinet metal frame.

In the back of the cabinet there is a white plastified cover sheet, in order to protect mechanical and electrical component parts, secured to the back of the cabinet by self-tapping screws; this cover has an access hole, marked with "a" in fig. 6, allowing to start the defrosting phase by acting directly on the timer (TS) (81).

At the bottom, compared to the cover sheet, there is the rear metal grill (29), that protects the rear access to the compressor compartment. The refrigerator power cord with plug (CS) (10) goes out through this grill.



FIG.2

## 2.2 USER'S CONTROLS

User's controls are positioned on the front panel (18). To reach all controls, it is necessary to remove the control panel cover (44) by pulling it out by the hole marked in figure 3. With reference to figure 3a, the component parts are the following:

main switch (IG) (31), marked with "1";  
lamps switch and defrosting led (IL) (32), marked with "2";

temperature control thermostat (TC) (80) with its knob (48), marked with "3";

mechanical analogue thermometer (79), marked with "4".

In the back of the cabinet there is an access to the defrosting timer (TS) (81) cam, to let the operator set the start of the defrosting phase by using a flat-head screwdriver: turning the cam clockwise the switch can be activated. The above-mentioned access opening is marked with "a" in figure 6.



FIG. 3

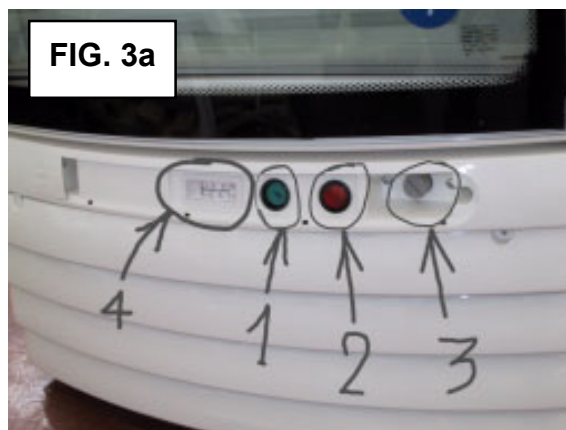

FIG. 3a

## 2.3 MECHANICAL AND ELECTRICAL COMPONENT PARTS IN THE TANK

The refrigerator is supplied with separate shelves (68): their position in the tank can be set as desired by moving the 4 shelf supports (70) on the four fixed racks (16) inside the tank; a bottom shelf (67) keep the product lifted from the tank floor for a correct air circulation.

In the tank there are two 36 W neon tubes (34), protected by polycarbonate shields (54); these neon tubes are positioned on the sides of the tank, behind the door.

On the top of the tank there is the plastic evaporator cover (8) on which the internal motor fan protection grill (28) is secured; a metal grill (27) keep the product spaced from the back wall for a correct air circulation.

To reach the mechanical component parts in the tank, it is necessary to disassemble the evaporator cover (8): remove the screws marked with "2" in fig. 4, in order to loosen the draining tube plastic stopper (46) marked with "1"; then remove the rear metal cover sheet, by removing the 9 screws shown in fig. 5, 6, 7 and 8, and loosen the screws marked with "1" in fig. 10, in order to remove the plastic toggle-joint (6) marked with an arrow in the same figure; at the end loosen the plastic draining tube (7) and remove the evaporator cover (8).

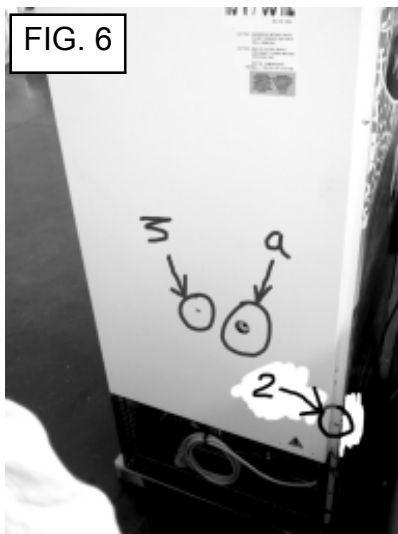
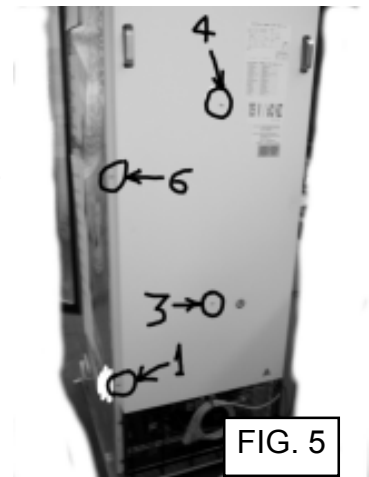
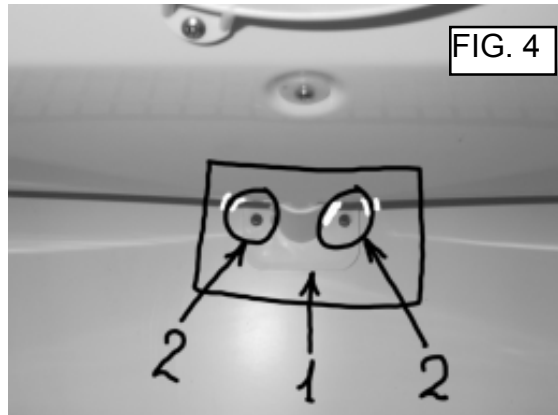

Under the cover (8) there are the following components (fig. 36):

- evaporator (20);
- end-of-defrosting thermostat (KFS) (5);
- evaporator motor fan (MI) (39) with its blade (40);
- evaporator motor fan metal support;
- evaporator motor fan rubber dumper feet (24);
- evaporator metal gutter (72);
- evaporator defrosting heater (REV) (66);
- evaporator gutter heater (RSG) (65).

Water produced during the defrosting phase, by the heat introduced by the evaporator heater, is collected into the metal gutter (72), positioned under the evaporator, and taken out from the tank through the draining tube (7) and the rear toggle-joint: a flexible plastic tube (fig. 9) discharges the water in the plastic tray (85) located in the compressor opening. To avoid ice forming on the evaporator draining tube (7), an electrical heater (gutter heater) (RSG) (65) provides to maintains it warm, so that the resulting water can flows away from the inner tank directly into the water tray (85), where a stainless steel pipe (58), connected to the compressor outlet pipe, helps it to evaporate.

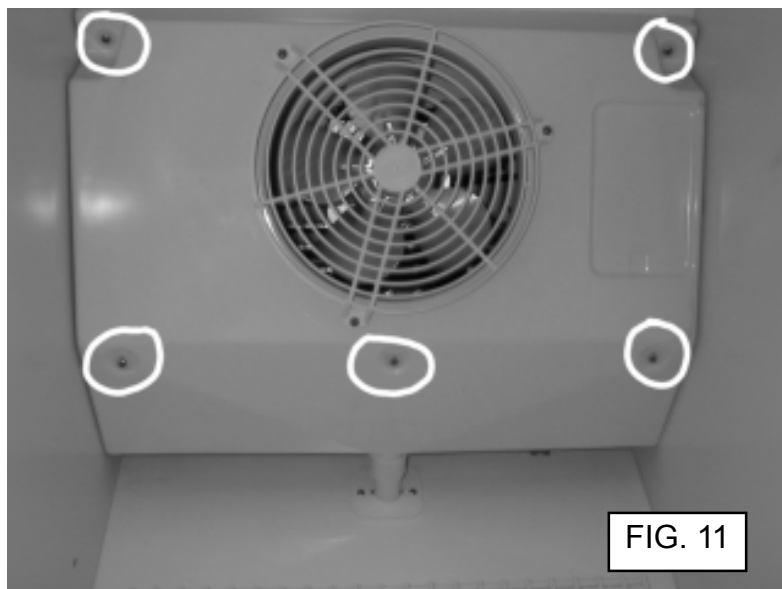
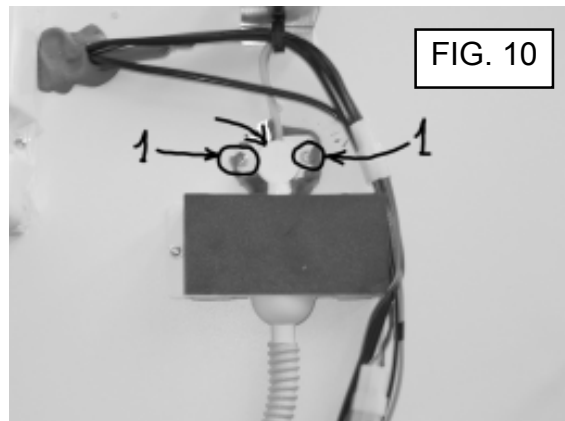
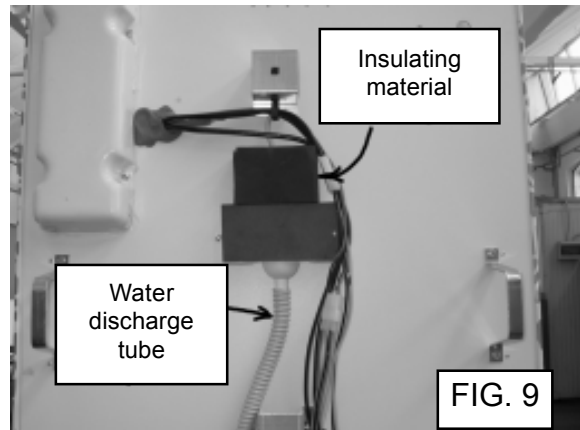

## 2.4 MECHANICAL AND ELECTRICAL PARTS IN THE COMPRESSOR COMPARTMENT

At the bottom of the refrigerator there is the compressor compartment, enclosed frontally by the plastic grill (26) and at the back by the metal grill (29). It is absolutely necessary that all the grills are not removed or deteriorated: obstructing the openings reduces the necessary air circulation for heat exchange; opening or breaking them exposes people to the risk of physical damages caused by contact with hot, moving or electrically live parts.

To reach the compressor compartment from the front side, it is necessary to remove the two screws marked in fig. 12 and then the front grill (26).

To access the controls located on the plastic support (18) it is necessary to extract the control panel by removing the screws that fix it on the door support frame: these two screws, represented in fig. 14 and 15, are located behind the controls support panel (44), removable as shown in the previous paragraph. One of these is hidden by the plastic stopper of the extension tube for the bottom tank drainage, marked with an arrow in fig. 13: press it and the spring will push it out automatically; rotate the extension tube 90° (fig. 14) and at this point the screw shown in fig. 14 is visible.

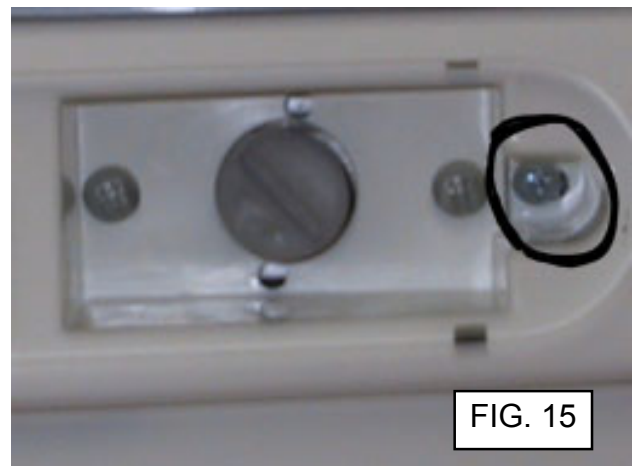
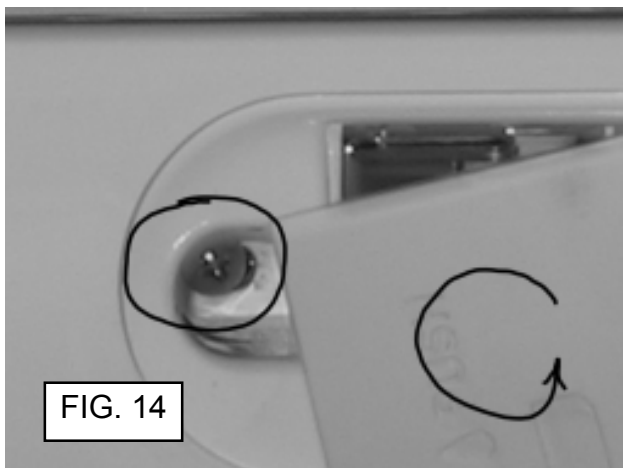
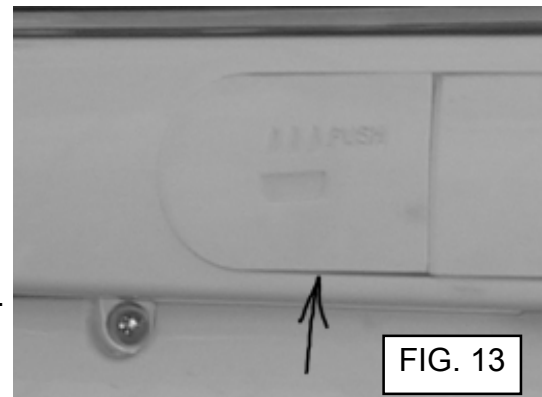

To access the compressor compartment from the back, remove the rear metal grill (29), shown in fig. 16 and 17, unscrewing the highlighted screws.

In the compressor compartment the condenser (14) is frontally positioned; on the right of the condenser, the isolation transformer (TI) (82) to supply the door heaters has been installed.

Just behind the condenser, there is the condenser motor fan (MC) (38) with its blade (41): the fan is installed so as to move air from the front of the refrigerator and push it towards the compressor and to the back of the compressor compartment.

Behind the condenser fan there is the compressor (CO) (12); on the right of the compressor, from the front to the back side, the following component parts are positioned: the water evaporation tray (85) with the hot stainless steel pipe (58), the defrosting valve (84) with its solenoid coil (2) and the dryer (21).

Behind the compressor, the low pressure pressostat (PBP) (88) is located.

In the back of the compressor compartment there are all the outputs to connect the pipes of the thermodynamic circuit, included the hot pipe for the cabinet frame heating.

Looking at the compressor compartment from the back, the power cord support plate is located on the right of the compressor (fig. 18c): the strain relief "2" (37) and the main relay "1" (RG) (63) are secured on it. (fig.18e)

In the compressor compartment there are also the electrical wirings supplying the isolation transformer and all the electrical devices located on the control panel. In the front and in the upper part there are outputs to supply the inner neon tubes.

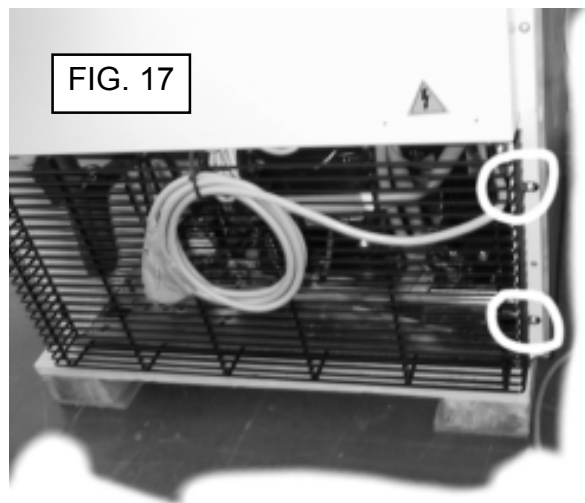

## 2.5 MECHANICAL AND ELECTRICAL COMPONENT PARTS AT THE BACK OF THE CABINET

Remove the rear metal cover sheet, by removing the 9 screws shown in fig. 5, 6, 7 and 8: on the right, above the compressor compartment, there is a metal support to which the electrical components are secured. These components are shown in fig. 18b:

1. Defrosting relay (RS) (61): double switching contacts to activate the defrosting phase.
2. Compressor relay (RC) (62): single contact, normally open, to operate the compressor.
3. Inner lamps starters (S2) (73): to strike the electric discharge in the gas lamp.
4. Display lamp ballast (AT1) (59): to supply the display lamp.
5. Inner lamps ballasts (AT2) (60): to supply the tank lamps.
6. Defrosting timer (TS) (81): controls the defrosting cycle.
7. Connecting terminal board.
8. EMC filter (FRF) (22).

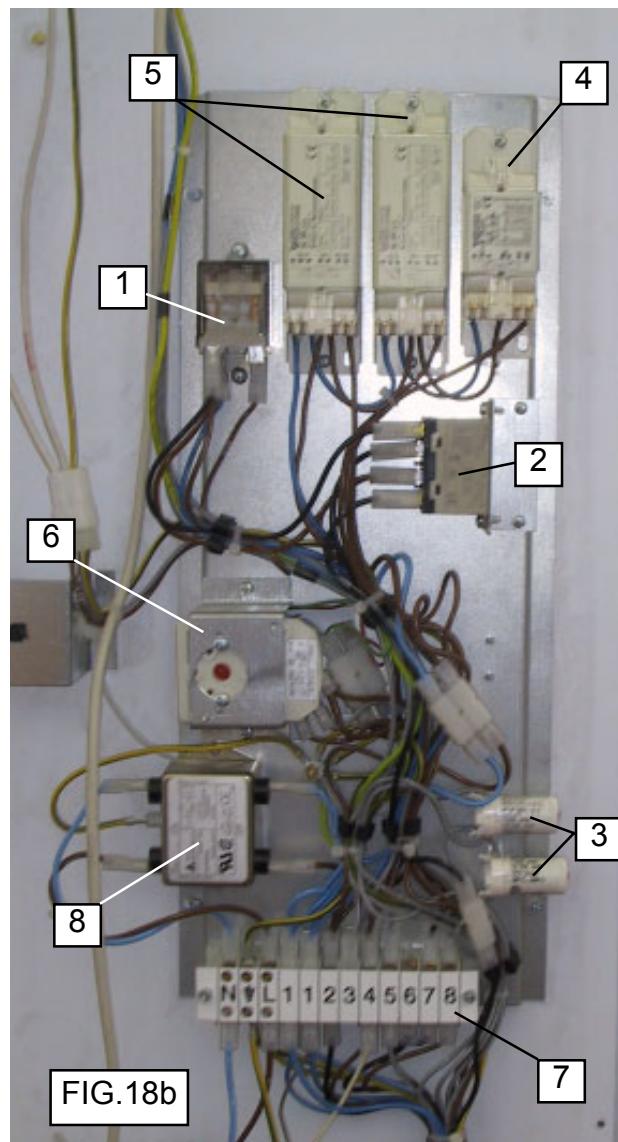

In the upper part, on the left, there is an access hole (fig. 18d nr. "3") to the inner tank for the wires supplying the electrical components located there.

On the same side there is an access hole for welding operations on the connection pipes of the evaporator (fig. 46), protected by an insulating cover (13) consisting of a plastic shell insulated with polyurethane: the cover, marked with "5" in figure 18d, is fixed to the cabinet body by four self-tapping screws, highlighted in fig. 45.

In the middle back, on the left-hand side of the refrigerator, there is an access hole for the thermometer and thermostat sensors, marked with "4" in fig. 18d.

The Evaporator gutter heater is marked with "2" in fig. 18d.

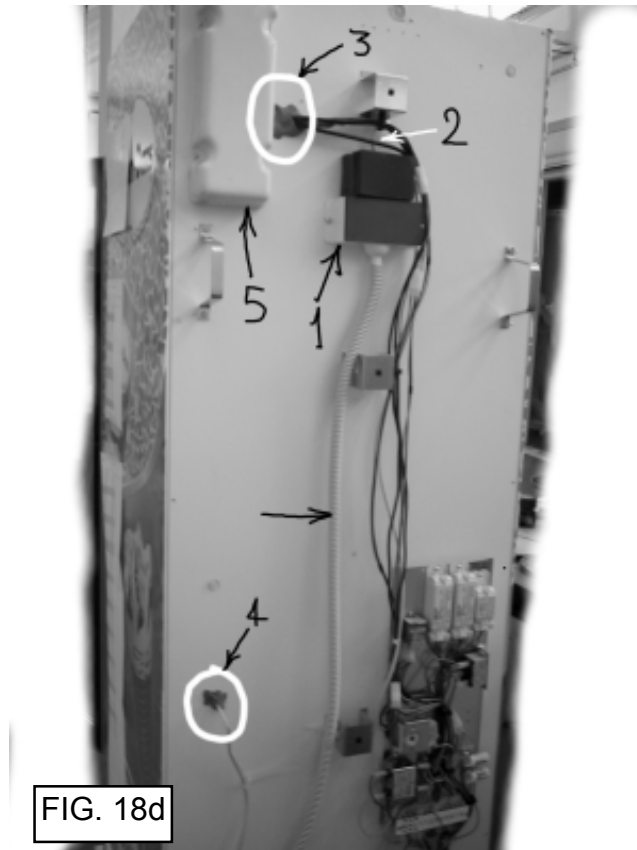
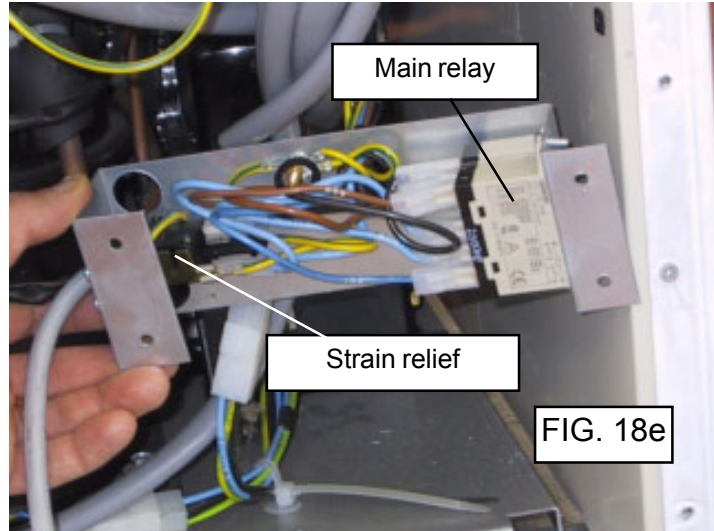
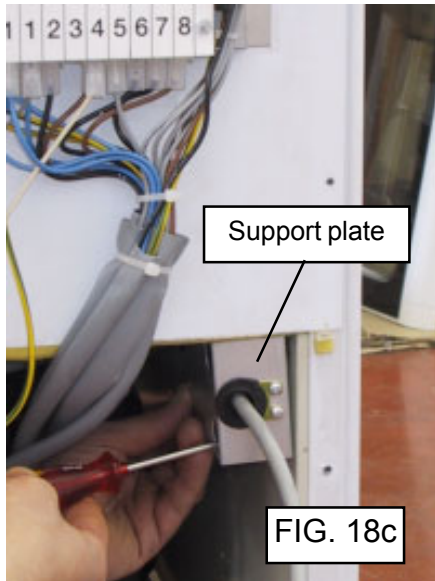

## 2.6 ELECTRICAL COMPONENTS IN THE DISPLAY COMPARTMENT

To access the display compartment loosen the 4 fixing screws circled in fig. 19 and 20 and remove the display plastic frame (9) and the display panel (42), indicated in fig. 22. In the display compartment you can see:

1. Door switch (IP) (36): it stops the evaporator motor fan every time the door is opened (fig. 21) and is located in the display plastic frame (9).
2. Display lamp (L1) (33): T5 type (o.d. 16 mm) and 13W.
3. Display lamp starter (S1) (73).

To access the display lamp starter remove the transparent panel (42), indicated by arrows in fig. 22.

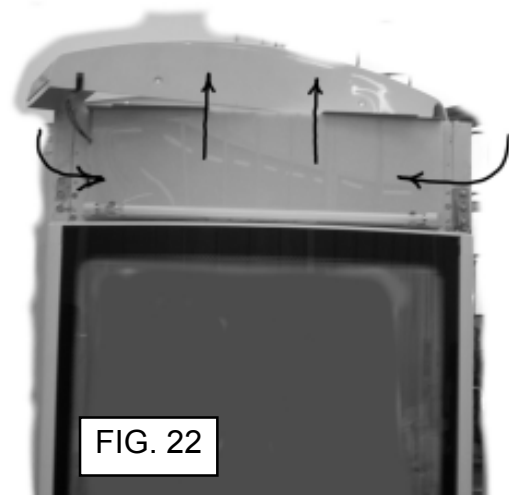
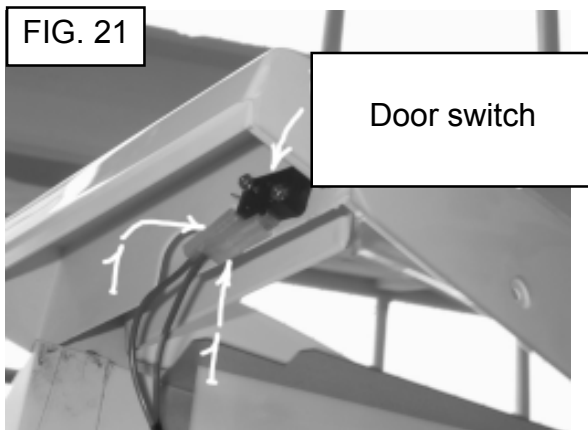
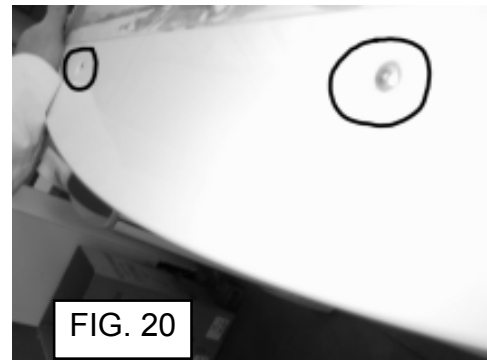
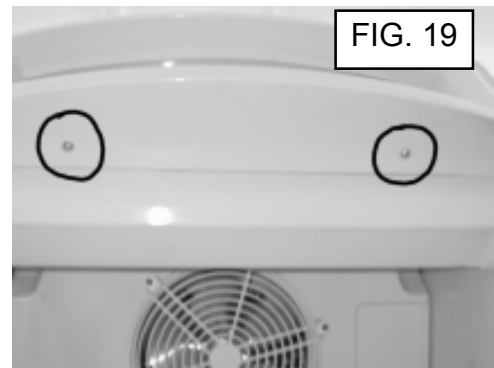

### **3 BASIC RULES FOR THE CORRECT OPERATION**

### 3.1 START-UP INSTRUCTIONS

After removing the packaging and installing the refrigerator in its final location, adjust the level feet (43) until the refrigerator is locked in place, on a flat surface.

In figure 23 one of the 2 front feet is shown rested on the ground: make sure that the refrigerator is perfectly installed on a flat surface, since the automatic closure system of the door might work improperly.

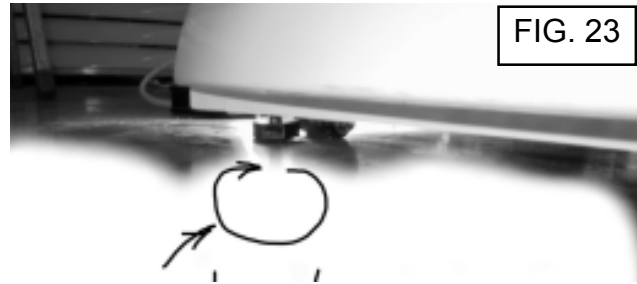

Plug into a suitable electric socket able to receive the type of plug supplied with the appliance.

Be sure that the electrical supply voltage is equal to that on the rating plate of the refrigerator.

Once you have plugged in, it is possible to start the refrigerator by pushing the main switch button; if the switch green led is on and, at the same time, the red defrosting light is on, the freezer is in defrosting cycle: then, to start the cooling phase, operate on the timer cam or wait for about 15 minutes until this phase is over.

When the machine starts the cooling phase, the defrosting red led is switched off and the compressor starts to operate, but the internal fan do not start immediately, until it is enabled to start by the end-of-defrosting thermostat (KFS) (5): the delay-action of the internal fan prevents the compressor for being overheated and allows to safeguard its functioning.

Therefore, when the machine is started for the first time, it is absolutely normal that the internal fan does not start: it is necessary to wait for about 10-15 minutes to see it coming into operation.

When the inside temperature reaches the value set by the thermostat (TC) (80), the compressor stops and begins the thermostatic cycles to maintain the desired temperature. This machine is designed to preserve ice-creams or frozen food and it is not suitable for freezing cycles: therefore, do not load the machine with food to be frozen but only with already frozen food.

Do not load food into the machine if the inside temperature is not stabilized to the value necessary for preserving it: after starting the machine, wait for at least 1 hour before loading products.

## 3.2 BASIC SAFETY RULES

*The supply voltage net, to which the refrigerator shall be plugged, must have an additional safety earth circuit.*

*The machine must be plugged into a socket with earth pole protected by a differential magnetothermic switch with rated Power = 15A and differential Power = 30mA.*

*Do not use extensions or multiple sockets.*

*Do not remove the protective grills: no action to solve possible malfunctions can be done by the user on the protected parts of the appliance.*

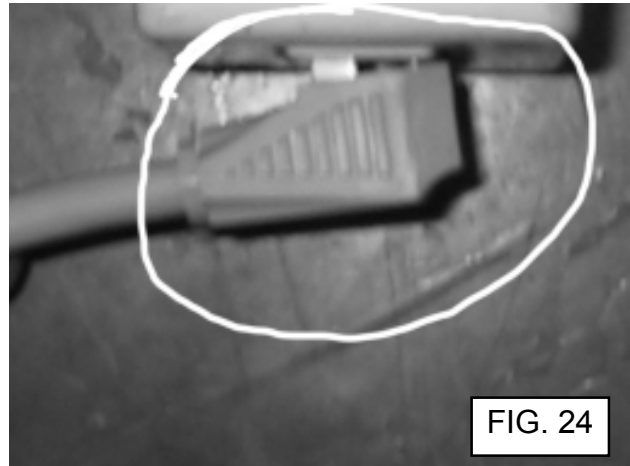

*Do not move the machine while it is plugged in.*

When the machine is plugged in, it is necessary to pay attention that the plug itself is well connected to the socket, that it is not going out by taking the position shown in figure 24. If the socket terminals are visible, as shown in figure 24, change the target socket; if you meet resistance in plugging in the machine or in case you cannot plug it in at all, do not force it and try to plug the machine into another socket.

If in the room you cannot find a suitable socket, make one installed by a skilled technician. Do not plug in if the refrigerator is not locked in place and levelled by its feet (47).

Handle the machine carefully, avoiding shocks or rough movements on the whole structure and mostly on the moving parts (door, shelves). The system, in the conditions it has been shipped from the factory, can guarantee an adequate protection level against electric shocks until all panels, protection grills and covers remain intact and in their original position.

It is recommended not to expose the door glass to possible shocks and not to force the door in the limit stop position.

Do not move the refrigerator when it is plugged into the electric socket. In any case, avoid disassembling any part of the refrigerator until it has been disconnected.

While disconnecting the machine do not pull the power cord, but act directly on the plug; it is absolutely necessary to avoid exposing the plug to torsions or flexions.

Do not interpose between plug and electric socket any connection device, such as multiple sockets, reduction gears, extensions and such like.

Avoid leaning on the upper part of the door, when it is open.

Avoid washing the refrigerator with running water or, in any case, avoid direct jets of water towards the refrigerator.

Do not touch the refrigerator with wet hands and/or feet.

Before carrying out any kind of maintenance operation on the refrigerator, make sure that the machine is disconnected.

For any maintenance operation, address to the technical assistance.

### **3.3 RULES TO IMPROVE THE EFFICIENCY OF THE SYSTEM**

Dealing with a glass door freezer, it is advisable that the glass door itself is located in a position where the sun rays are not directed to the glass, in order to avoid abnormal heat absorption; in any case, keep the machine far away from heat sources.

Do not obstruct the external openings (front and back grills), leaving the correct air circulation inside the compressor compartment and take care to have adequate space around the refrigerator.

Clean periodically the condenser from dirt and accumulated debris: a dirty condenser reduces performances and shortens the life of the compressor.

Inside the tank, make sure that the load does not obstruct the grills, giving access to the internal motor fan: respect the load limits.

Open the door and keep it open as long as it is necessary to introduce or take products: make these two operations as shortly as possible.

## **4 MAINTENANCE INSTRUCTIONS**

## 4.1 MAINTENANCE OF THE CABINET

### 4.1.1 DOOR REPLACING

To replace the door remove the display plastic frame (9) by unscrewing the 4 screws as shown in fig. 19 and 20; then remove the front grill (26) and the control panel (18) with its cover (44) as already described at paragraph 2.4. Disconnect the cable of the glass and frame heaters by removing the door electrical terminal connection located in the compressor compartment, as shown in figure 25 and extract the terminals from the junction by means of a flat screwdriver as in figure 26.

Go now to the upper part of the door and rotate, by means of the screwdriver "1", the slotted head as much as necessary to remove the screw by means of the screwdriver "2", as shown in figure 27; loosen now the hinge screws as in figure 28.

Thus, raise the door and remove it from the lower hinge as in figures 29 and 30.

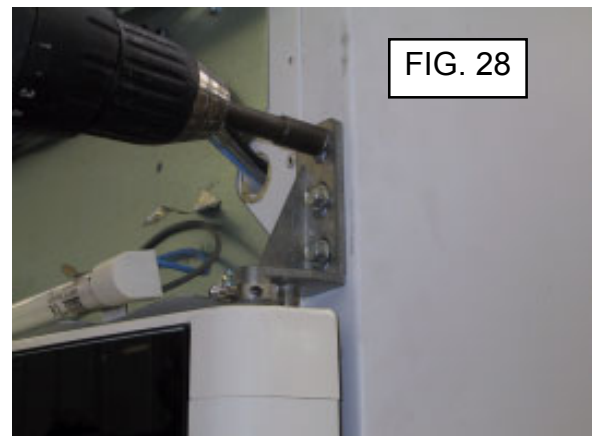
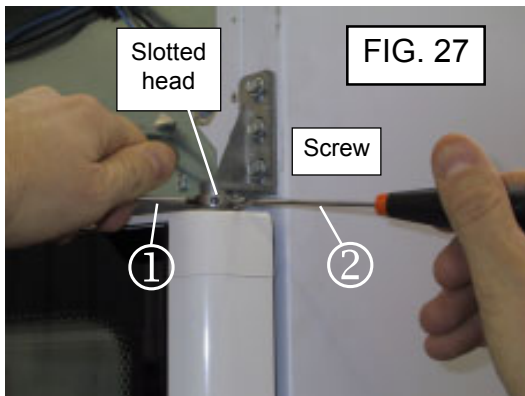
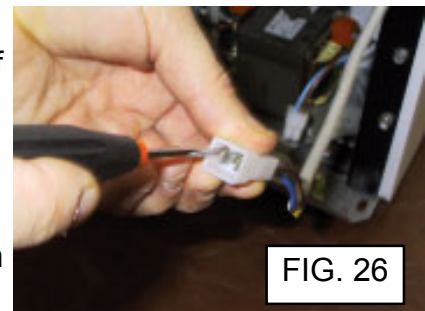

## 4.2 MAINTENANCE OF THE INNER TANK

### 4.2.1 NEON TUBES REPLACING

To replace the neon tubes remove the polycarbonate shields by unscrewing the self-tapping screw shown in figure 31: extract now the covering itself from its own guides, levering by means of a slot-head screwdriver on the bottom edge of the shield, as shown in figure 32.



## 4.2.2 EVAPORATOR MOTOR FAN REPLACING

Remove the evaporator cover (8) and the back metal cover in the rear side of the cabinet, as already explained at paragraph 2.3 and 2.5. Disconnect the terminal junction of the motor fan located in the back side, as indicated in fig. 35, and extract the terminals, proceeding as already explained in the paragraph 4.1.1 in fig. 26. Remove the insulating mastic highlighted in fig. 35 and pull the wires inside the tank; remove the aluminium blade (38) by unscrewing the hexagonal screw marked with "2" in fig. 38 and then loosen the 4 screws indicated with "1" in fig. 38 and 39, in order to disconnect the motor fan support.

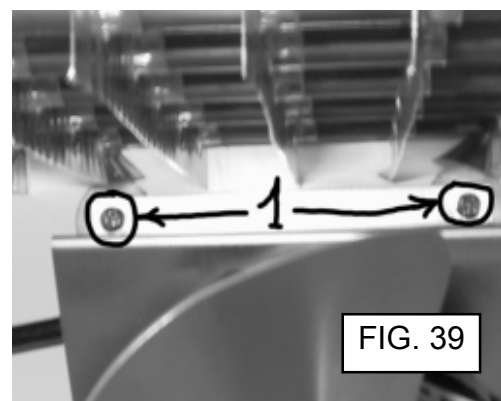
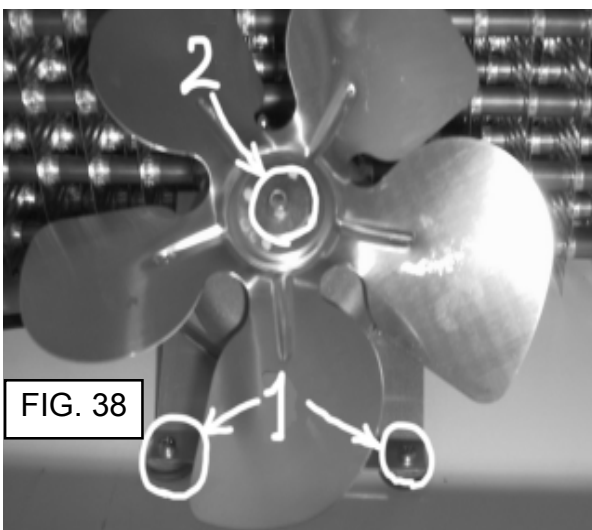
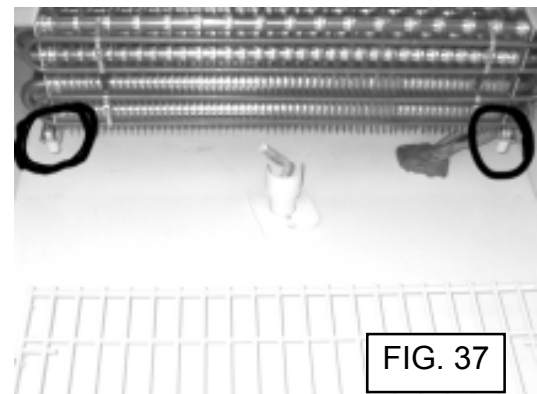
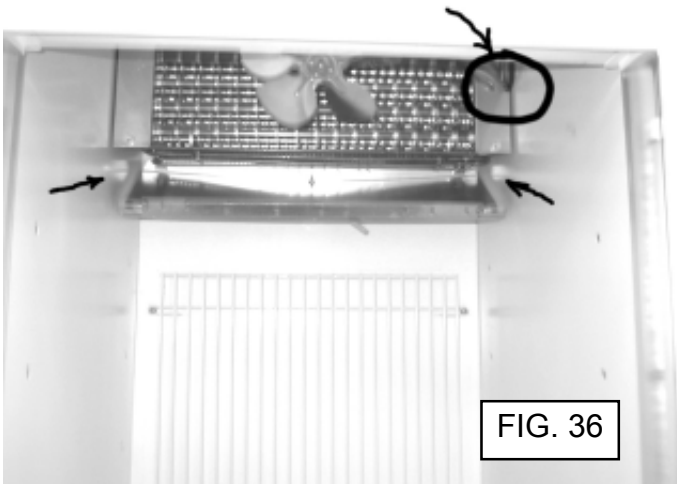
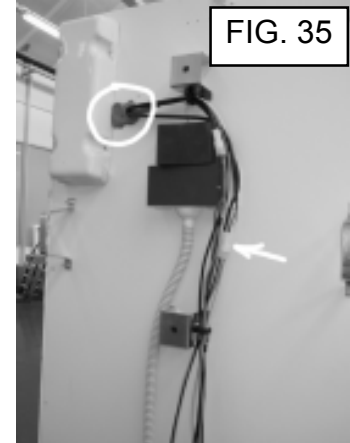
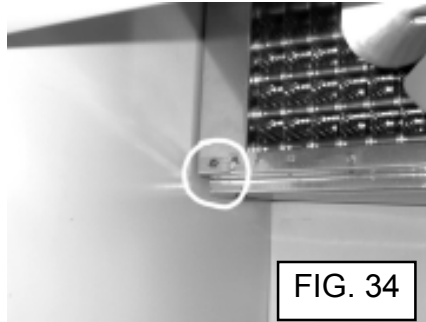
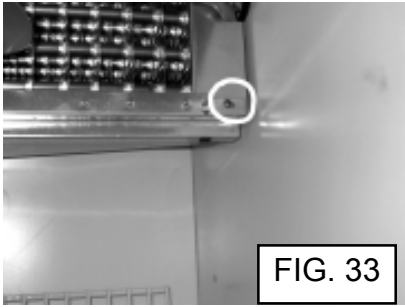

### 4.2.3 EVAPORATOR HEATER REPLACING

Remove the evaporator cover (8) and the back metal cover in the rear side of the cabinet, as already explained at paragraph 2.3 and 2.5. Disconnect the terminal junction of the heater, marked with an arrow in fig. 40, and extract the terminals, proceeding as already explained in the paragraph 4.1.1 in fig. 26. Remove the insulating mastic highlighted in fig. 35 and pull the wires inside the tank. Remove the evaporator gutter, loosening the screws indicated in fig. 33 and 34: lower the frontal part of the gutter and push it back, in order to move it away from the rear supports indicated in fig. 37. Cut the metal fasteners of the evaporator heater, circled in fig. 41, and replace the heater (REV) (66).

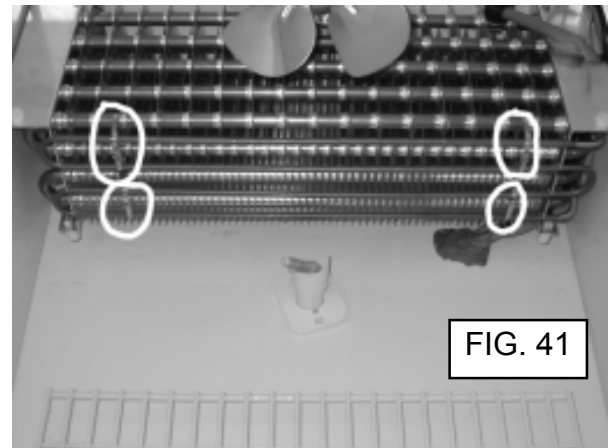
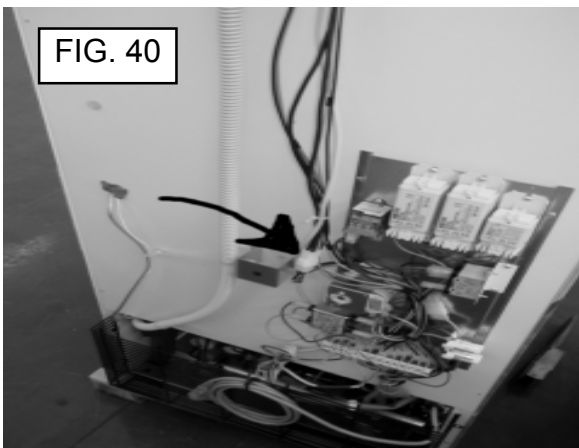

### 4.2.4 EVAPORATOR GUTTER DRAINING TUBE HEATER REPLACING

Remove the evaporator cover (8) and the back metal cover in the rear side of the cabinet, as already explained at paragraph 2.3 and 2.5. Disconnect the terminals of the gutter heater from the terminal board ("7" in fig. 18b). Remove the insulating adhesive cover (indicated in fig. 9) of the plastic toggle joint (6) and remove it, loosening the screws marked with "1" in fig. 10. Remove the heater (RSG) (65) and replace it.

## 4.2.5 END-OF-DEFROSTING THERMOSTAT REPLACING

Remove the evaporator cover (8) and the back metal cover in the rear side of the cabinet, as already explained at paragraph 2.3 and 2.5. On the back of the cabinet find and disconnect the two-way junction connecting the fixed thermostat as par fig. 42; remove the terminals from the junction, proceeding as already explained in the paragraph 4.1.1 in fig. 26, and pull the two black cables inside the inner tank. Remove the thermostat from the evaporator acting with a pair of pliers as shown in fig. 43. Extract the thermostat wires from their sheath and introduce the new ones. During the installation the new thermostat on the evaporator, it is recommended to place it in the position shown in fig. 43, by pressing on the fixing spring until the spring itself has hooked the pipe and complete the operation by rotating the thermostat around its connection point, until the concave part, marked with an arrow in fig. 44, is rested on the pipe.

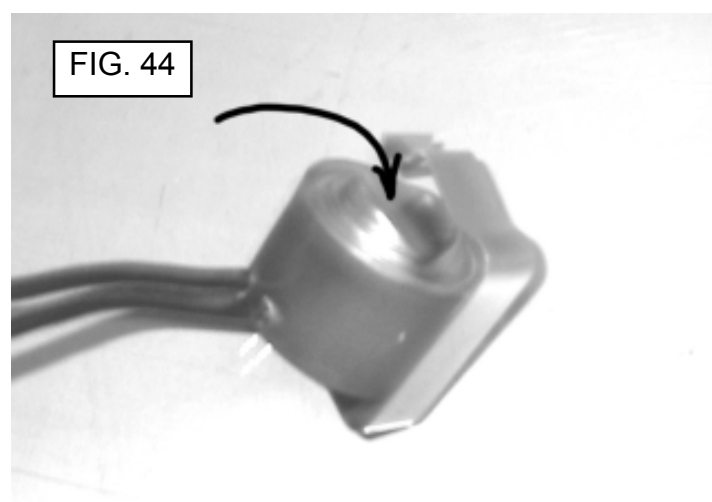
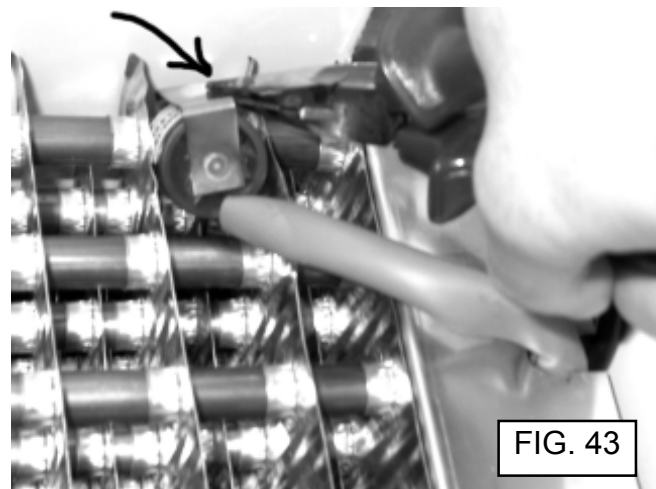
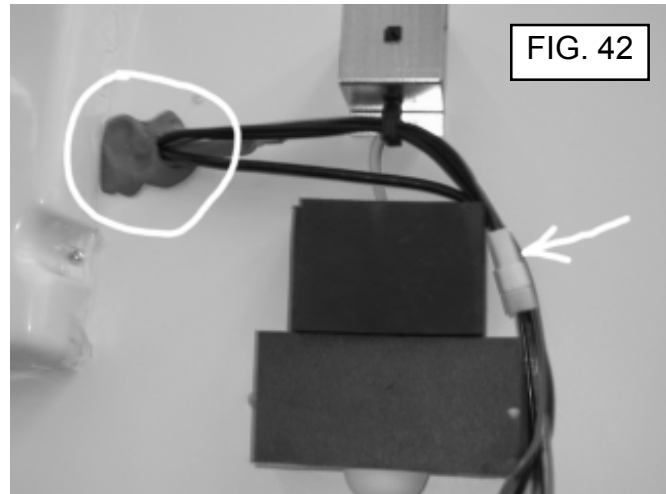

## 4.2.6 EVAPORATOR REPLACING

Remove the evaporator cover (8) and the back metal cover in the rear side of the cabinet, as already explained at paragraph 2.3 and 2.5.

Empty the refrigerating circuit, recovering the refrigerant into a suitable container to re-use it later.

From the back of the cabinet remove the plastic insulated cover box (15) by unscrewing the 4 screws shown in figure 45.

Remove the sealing coat, marked with a circle in figure 46, covering the hole at the top near the welded joints and release the pipe and the capillary tube from the welds always shown in figure 46.

Remove the evaporator heater and the end-of-defrosting thermostat as already described in the previous paragraphs.

Inside the tank remove the screws shown in fig. 47, 48, 49 and 50, that fix in position the evaporator; pull backwards and, at the same time, lower the evaporator until the pipes connecting it to the thermodynamic circuit are completely inside the tank.

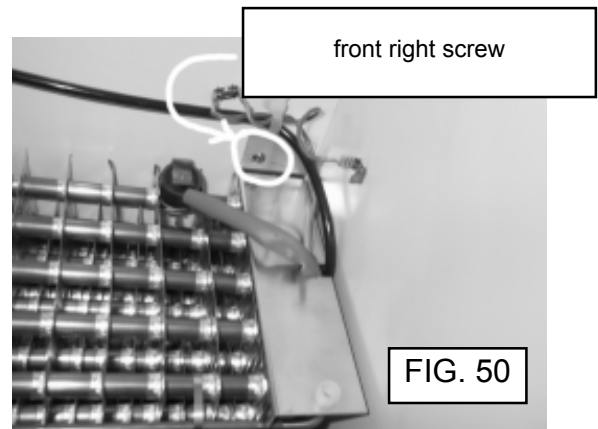
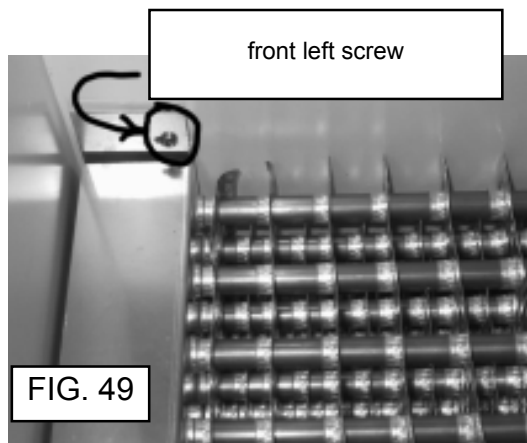
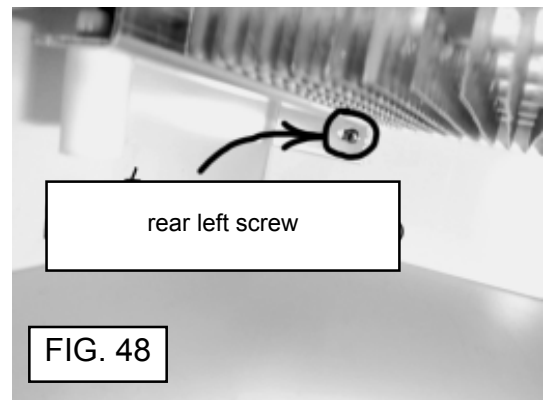
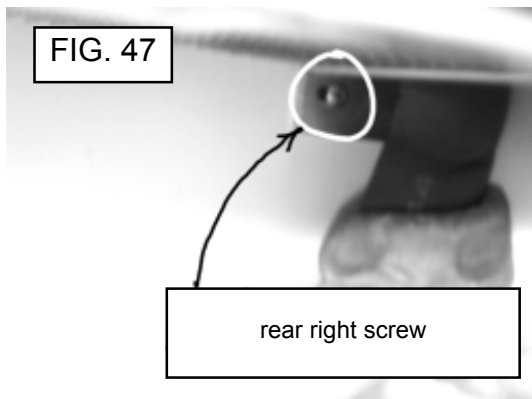
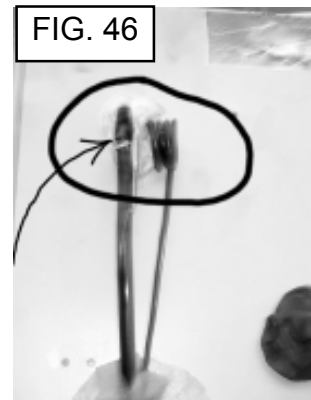

## 4.3 MAINTENANCE OF THE COMPRESSOR COMPARTMENT

### 4.3.1 CONDENSER MOTOR FAN REPLACING

Move to the back of the cabinet and remove the rear grill as previously described.

Disconnect the motor fan by disconnecting the terminal junction and remove the terminals from the junction, proceeding as already explained in the paragraph 4.1.1 in fig. 26.

Remove the hexagonal-head screws securing the motor fan support to the base plate using a 10 mm spanner. Let the motor fan move to one side of the compressor, as shown in fig. 51; unscrew the hexagonal-head screw fixing the blade to the motor and remove the screws fastening the motor to its metal support.



### 4.3.2 LOW PRESSURE PRESSOSTAT REPLACING

Move to the back of the cabinet and remove the rear grill as previously described.

Empty the refrigerating circuit, recovering the refrigerant into a suitable container to re-use it later. Release the pipe and the capillary tube from the welds shown in figure 52a.

Remove the pressostat cap by loosening the fixing screw highlighted in fig. 52b and disconnect the wires from the pressostat terminals: take note of the position of each wire, in order to restore them later in the right way. For any information always refer to the wiring diagram SE211/06.

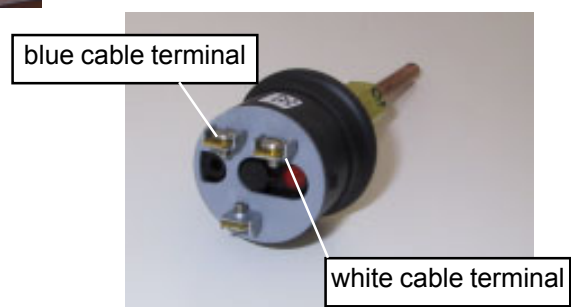
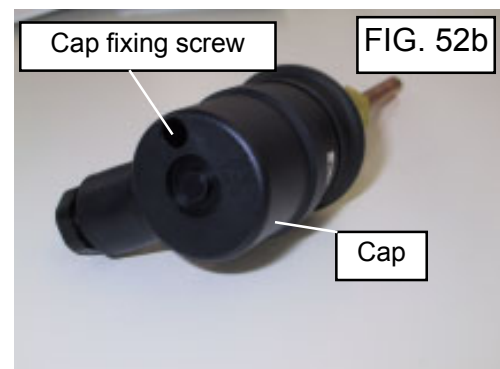
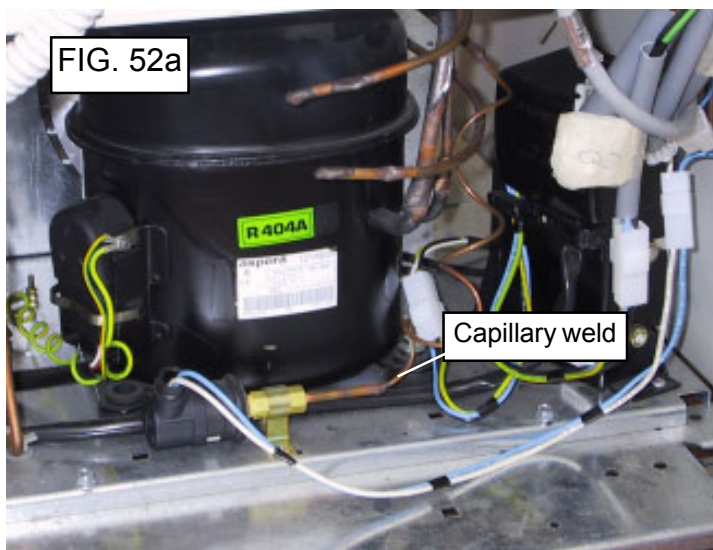

### 4.3.2 TANK THERMOSTAT REPLACING

Remove the metal cover sheet in the rear side of the cabinet, as already explained at paragraph 2.3 and 2.5.

Inside the tank remove the product spacer grill (27), unscrewing the 8 screws highlighted in fig. 53 and the sensor plastic support (74), marked with "S" in fig. 54, loosening the 2 screws marked with "V". Remove the insulating material from the access hole of the thermometer and thermostat sensors, marked with a circle in fig. 55. Pull outwards the thermostat sensor. In this position the sensor is coated by a transparent sheath, marked with an arrow in fig. 55. Release the thermostat from its seat, removing the front grill (26) and control panel (18) unscrewing the two fastening screws as already explained in fig. 12, 13, 14 and 15 in paragraph 2.4: extract the adjusting knob (fig. 56) and loosen the nut highlighted in fig. 57.

Introducing the new thermostat, be careful to insert the sensor in the appropriate position in the compressor compartment and pay attention to secure the sensor by means of the bearing clamps, as par fig. 58.

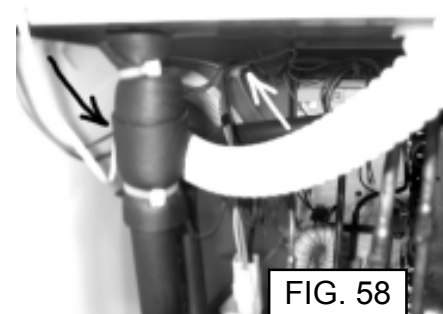
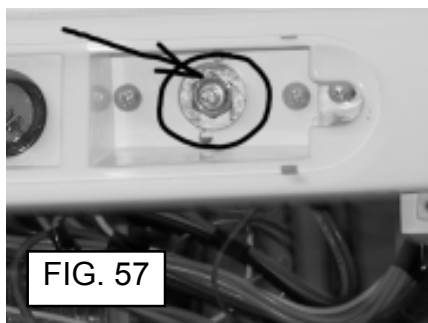
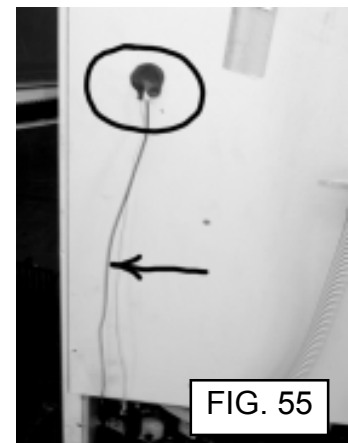
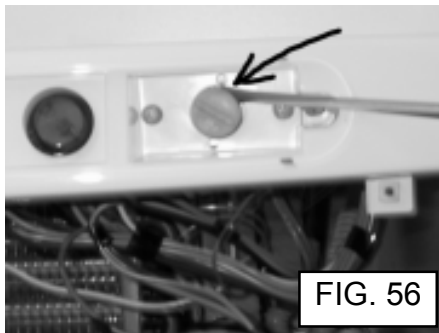
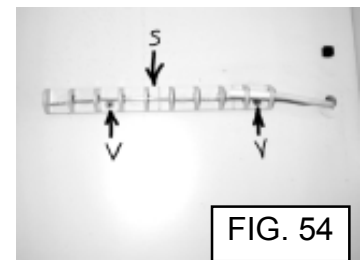
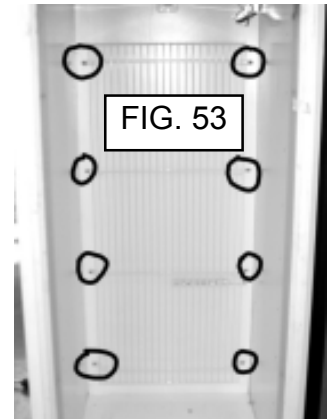

# 5 UTILITY



## 5.1 FUNCTIONAL WIRING DIAGRAM

Here below the wiring diagram SE211/06, describing the functioning of the freezer, is shown.

<b>SCHEMA ELETTRICO FUNZIONALE STAR 55 MR (SE0211/06)</b> <b>FUNCTIONAL WIRING DIAGRAM STAR 55 MR</b>		
<b>REF.</b>	<b>DENOMINATION</b>	<b>DENOMINAZIONE</b>
AT1	Display neon ballast	Reattore neon cassonetto
AT2	Inner neon ballast	Reattore neon vasca
CO	Compressor	Compressore
F	Transformer fuse	Fusibile trasformatore
FRF	EMC Filter	Filtro radio frequenze
IG	Main switch	Interruttore generale
ILS	Light switch with defosting light	Interruttore luci con spia sbrinamento
IP	Door switch	Interruttore porta
KFS	End of defrosting thermostat	Termostato di fine sbrinamento
L1	Display neon	Neon cassonetto
L2	Inner neon	Neon vasca
MC	Condenser motor fan	Motoventola condensatore
MI	Inner motor fan	Motoventola interno vasca
PBP	Low pressure operating switch	Pressostato bassa pressione
RC	Compressor relay	Relay comando compressore
REV	Evaporator heater	Resistenza evaporatore
RS	Defrosting relay	Relay comando fase di sbrinamento
RSG	Water discharge heater	Resistenza scarico acqua
RT	Door frame heater	Resistenza telaio porta
RV	Door glass heater	Resistenza vetro riscaldato
S1	Display neon starter	Starter neon cassonetto
S2	Inner neon starter	Starter neon vasca
TC	Thermostat	Termostato
TI	Isolating transformer	Trasformatore di isolamento
TS	Defrosting timer	Timer di sbrinamento
VM	Delivery valve	Valvola di mandata



## 5.2 SPARE PARTS LIST

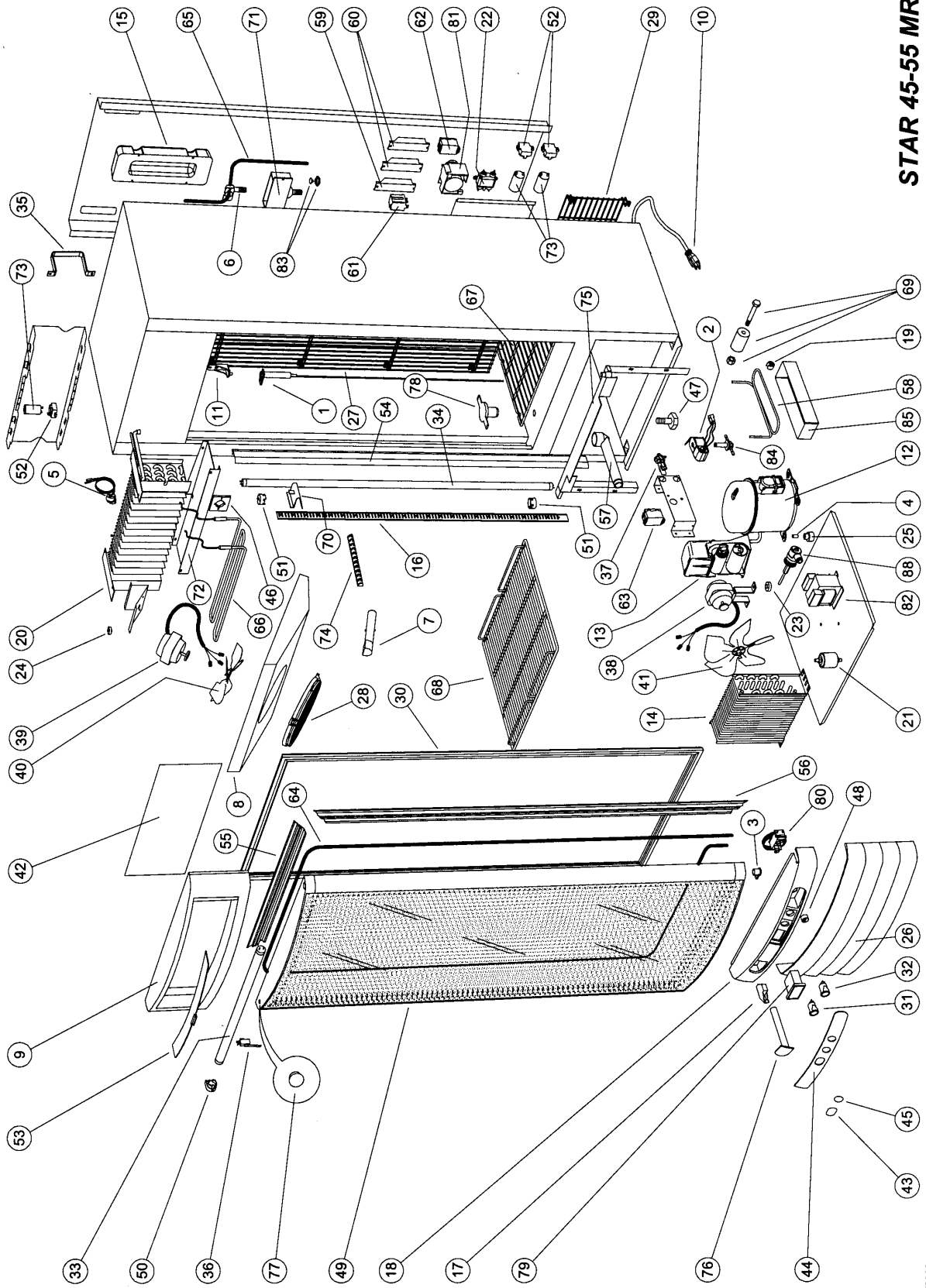

**STAR 45-55 MR**  
Dis. ES206

4/2002

**Model STAR 55 MR IARP USA code 9254006**

**GENERAL LIST**

Ref.	Description	Qty	Code	Price IFL
1	BLOCCO CHIUS.B.TORS.MM1150	1	3302075	
	TORSION BAR CLOSING SYSTEM			
	VITE 4,2X 16 TSP+ZINCATA	1	0511030	
ZINC REAMED SCREW 4,2X16				
2	CABL. BOBINA VALVOLA SOLE.VR3	1	3601509	
	SOLENOID COIL FOR DEFROSTING VALVE EVR3			
3	BOCCOLA CERN.INF.BIANCA	1	0534014	
	DOOR LOWER PLASTIC BUSH			
	VITE 4,2X 16 TSP+ZINCATA	1	0511030	
	ZINC REAMED SCREW 4,2X16			
4	BOCCOLA T-J SERIES ASPERA	4	0534015	
	COMPRESSOR BUSH T-J SERIES ASPERA			
5	CABL.KLIXON F.SBRINAMENTO	1	3600437	
	END OF DEFROSTING THERMOSTAT			
6	CANOTTO DREN.A GOMITO EIS/VFP	1	0543075	
	PLASTIC TOGGLE JOINT EIS/VFP			
7	CANOTTO DREN.EVAP.EIS34	1	0543041	
	EVAPORATOR PLASTIC DRAINING TUBE			
8	CARTER EVAP.EIS32 ABS BIANCO	1	3700042	
	WHITW ABS EVAPORATOR COVER			
9	CASS.STAR34 ABS BIANCO	1	0440100	
	WHITE ABS DISPLAY FRAME FOR STAR MODEL			
10	CAVO SPINA 3X1,5 MM2500 USA	1	3300799	
	POWER CORD WITH USA PLUG 3X1,5 MM2500			
11	CERN.SUP.ZAMA GREZZA DX	1	0415134	
	UPPER RIGHT DOOR HINGE			
12	COMPR.T2178GK 115/60 CSR	1	0210146	
	COMPR.T2178GK 115/60 CSR			
	RELAY GE 3ARR 3B3P3	1	0210330	
	RELAY GE 3ARR 3B3P3			
13	COND.DI MARCIA 25 MF 450V	1	0210424	
	RUN CAPACITOR 25 microF 450V			
	COND.DI SPUNTO 145/174 MF 165V	1	0210457	
	START CAPACITOR 145/174 microF 165V			
14	CONDENS.ALETT.36T.EIS55 U.L.	1	0130076	
	FINNED CONDENSER 36 TUBES UL			
15	COP.ABS TUBI POST.EIS 34	1	3700089	
	REAR PIPING INSULATED PLASTIC COVER			
16	CREM.AX/AB500/EC/EF/VFP50TRAN.	4	160372	
	STAINLESS STEEL RAIL FOR SELH SUPPORTS			
17	CRICCHETTO MINI LATHC C/SMUSSO	1	0202075	
	DRAINING TUBE STOPPER COUPLING			
18	CRUSCOTTO STAR ABS BIANCO	1	0411077	
	WHITW ABS CONTROLS SUPPORT FOR STAR MOD.			
19	DISTANZ.NYLON TUBO INOX	5	0544003	
	HOT PIPE SPACER			
20	EVAP ALETT.20TUBI EIS34 R 1V	1	0119136	
	FINNED EVAPORATOR 20 TUBES			

**Model STAR 55 MR IARP USA code 9254006**

**GENERAL LIST**

Ref.	Description	Qty	Code	Price ITL
21	FILTRO CARTUCCIA SOLIDA DN032	1	0145031	
	SOLID CORE DRYER DN032			
22	FILTRO RF 20DKBG5 115/250V 20A	1	3301671	
	EMC FILTER 20DKBG5 115/250V 20A			
23	GOMMINO AMMORT.D.24X6 NERO	4	0403007	
	COND. MOTOR FAN BLACK DUMPER FOOT 24X6mm			
24	GOMMINO AMMORT.D.24X6 NEUTRO	4	0403012	
	EVAP. MOTORFAN TRANS. DUMPER FOOT 24X6mm			
25	GOMMINO T-J SERIES ASPERA	4	0403021	
	COMPRESSOR DUMPER FOOT T-J SERIES ASPERA			
26	GRIGLIA ANT.STAR ABS BIANCO	1	0427204	
	FRONT ABS WHITE GRILL			
27	GRIGLIA INTERNA VFP50/EIS34	1	0427079	
	STAR 55 SHELF SPACER REAR GRILL			
28	GRIGLIA MOTOVENTOLA INT. ABS	1	0427171	
	EVAPORATOR MOTORFAN ABS COVER GRILL			
29	GRIGLIA POST.EIS34/STAR34 NERA	1	0427407	
	STAR55 COMPR. OPENING REAR COVER GRILL			
30	GUARN.MAGN.EIS/VFP50/STAR	1	0313010	
	STAR55 DOOR BLACK MAGNETIC GASKET			
31	INTERR.BIP.LUM.VERDE ROTONDO	1	0202026	
	MAIN BIPOLAR ROUND SWITCH GREEN LIGHTING			
32	INTERR.UNIP.ROT.C/SPIA INDIP.	1	0202027	
	LIGHT ROUND SWITCH WITH RED DEFR. LIGHT			
33	LAMPADA 13W D.16 MM 516 K54	1	0200051	
	13W o.d.16 mm DISPLAY LAMP K 54			
34	LAMPADA 36W D.26 MM1200 K54	2	0200048	
	36W o.d.26 mm INNER LAMP 435 K 54			
35	MANIGLIA GIADA POSTERIORE	2	0400077	Non Presente
	REAR HANDLE MODEL GIADA			
36	MICROINT.VMN15S03C0	1	0202028	
	DOOR MICROSWITCH VMN15S03C0			
37	MORSETTIERA PA84 E SERRACAPO	1	0001012	
	PA84E TERMINAL BOARD WITH STRAIN RELIEF			
38	MOTORE 16W30 T3 115/60 UL C500	1	0220079	
	COND. MOTOR FAN 16W30 T3 115/60 UL C500			
	STAFFA MOTOV.TIPO B DIR.H.72			
39	MOTORE 9W20 T1 115/60 UL C1200	1	0220077	
	EVAP. MOTOR FAN 9W20 T1 115/60 UL C1200			
40	PALA ALLUMINIO A 200-28	1	0407001	
	ALUMINIUM BLADE A 200-28			
41	PALA ALLUMINIO A 230-34	1	0407013	
	ALUMINIUM BLADE A 230-34			
42	PANN.CASS.STAR NEUTRO	1	0340128	
	NEUTRAL DISPLAY PANEL			
43	PANN.CENTR.STAR DISPLAY	1	0411065	
	THERMOMETER PLASTIC COVER			

**Model STAR 55 MR IARP USA code 9254006**

**GENERAL LIST**

Ref.	Description	Qty	Code	Price ITL
44	PANN.CRUSC.ASTRA ABS BIANCO	1	0440076	
	WHITW ABS CONTROL SUPPORT COVER			
45	PANN.INTERR.LINEA STAR	1	0411066	
	MAIN SWITCH PLASTIC COVER			
46	PIASTRINA BLOCCAGGIO CANOTTO	1	0543022	
	EVAPOR. DRAINING TUBE PLASTIC STOPPER			
47	PIEDINO ESAGONALE 10MAX43 R128	2	0403014	
	HEXAGONAL FOOT 10MAX43 R128			
48	POMELLO TER.ABS GRIGIO P.429C	1	0413010	
	THERMOSTAT GRAY ABS KNOB P. 429C			
49	PORTA STAR BIANCA U.L.C/MAN.	1	0070912	
	COMPLETE STAR55 WHITE DOOR			
50	PORTALAMPADA G5 109686 U.L.	2	3301891	
	LAMPHOLDER G5 109686 U.L.			
51	PORTALAMPADA 101784 U.L.	4	3301800	
	LAMPHOLDER G13 101784 U.L.			
52	PORTASTARTER 430 U.L.	3	3301794	
	STARTER HOLDER 430 UL			
53	PROF.POLIC.COPRILAMPADA STAR	1	0320339	
	DISPLAY LAMP COVER PROFILE FOR STAR MODEL			
54	PROF.POLIC.C431 MM1298	2	0320600	
	INNER LAMP COVER PROFILE C431 L.1298mm			
55	PROF.PVC VP1015 MM 661 NERO	2	0320232	
	BLACK PVC PROFILE VP1015 mm 661			
56	PROF.PVC VP1015 MM1418 NERO	2	0320344	
	BLACK PVC PROFILE VP1015 mm 1418			
57	PROLUNGA CANOTTO EIS30/GT D.17	1	0543000	
	"L" SHAPE DRAINING TUBE EIS 30/GT o.d. 17mm			
58	RACCORDERIA EV.ACQUA INOX	1	0160781	
	STAINLESS STEEL TUBE FOR WATER EVAPORAT.			
59	REATTORE 13W 120/60 HZ U.L.	1	3300611	
	BALLAST 13W 120/60 HZ U.L.			
60	REATTORE 40W 115/60 U.L.	2	3301806	
	BALLAST 40W 115/60 U.L.			
61	RELE'FINDER 6282-8-120-0006	1	3301890	
	DEFROSTING RELAY FINDER 6282-8-120-0006			
62	RELE'G7L-1A-TUB 120VCA	1	3300708	
	COMPR. RELAY G7L-1A-TUB 120VCA			
63	RELE'G7L-2A-TUB 120VCA	1	3301807	
	MAIN RELAY G7L-2A-TUB 120VCA			
64	RESISTENZA 10W/MT 230V TELAIO	1	3301813	
	DOOR FRAME HEATER 10W/m 230V			
65	RESISTENZA 20W/MT EIS/STAR 45	1	0205315	
	EVAP. GUTTER HEATER 20W/m 115V EIS/STAR 55			
66	RES. COR. INOX 500W EVAPORATORE	1	0205301	
	EVAPOR. HEATER 500W			
67	RIPIANO DI FONDO VFP 50	1	0427077	
	BOTTOM SHELF			

**Model STAR 55 MR IARP USA code 9254006**

**GENERAL LIST**

Ref.	Description	Qty	Code	Price ITL
68	RIPIANO VASCA VFP50/EIS 55	4	0427078	
	TANK SHELF			
69	RULLINO NYLON D.23 MM 38	4	0402000	
	NYLON ROLLER o.d. 23 mm l. 38 mm			
	DADO 6MA AUTOBLOCCANTE	4	0505004	
	SELFLOCKING NUT 6MA			
	PERNO D.7 FIL. M6 MM 55	4	0530013	
	PIVOT o.d. 7 mm M6 l. 55mm			
70	SACCHETTO N°16 GANCI SUPP.RIP. 16 SELF SUPPORTS	1	0160741	
71	SCATOLA VALVOLE SCARICO ACQUA	1	0425000	
	WATER DISCHARGE BOX			
	PALLA D.38 PER SCARICO ACQUA	1	0426000	
	BALL o.d. 38 mm FOR WATER DISCHARGE			
72	SGOCCIOL.EIS 34 M.RES.L.ZN.	1	3601666	
	EVAPOR. ZINC COATED GUTTER EIS 34			
	COP.SCARICO SGOCC.EIS34 L.ZN.	1	3601665	
	DRAINING TUBE ZINC COATED STEEL SHEET			
	RINF.SGOCCIOL.EIS 32/34 L. ZN	1	7072534	
	GUTTER REINFORCEMENT			
	STAFFA SGOCCIOL.EIS 34 1V L.ZN	1	3601664	
	GUTTER SUPPORT			
73	STARTER FS11 4/80W 220V U.L.	3	0207012	
	STARTER FS11 4/80W 220V U.L.			
74	SUPP.BULBO TERMOM./TERMOS.ABS	1	0542048	
	THERMOM. THERMOSTAT PLASTIC SUPPORT			
75	SUPP.INF.PORTA STAR M RES.NERO	1	0162584	
	DOOR FRAME SUPPORT			
76	FLANGIA PER TAPPO CANOTTO ABS	1	0312153	
	TANK ABS DRAINING TUBE			
	TAPPO CANOTTO ASTRA ABS BIANCO	1	0312004	
	TANK ABS DRAINING TUBE WHITE STOPPER			
77	TAPPO COPRIVITE ASTRA/STAR	2	3300061	
	DOOR SCREW COVER STAR 55			
78	TAPPO DREN.INTERNO NEUTRO	1	0312038	
	INNER DRAINING TUBE STOPPER			
79	TERMOMETRO LETT.OR.B2000 NERO	1	0406036	
	HORIZONTAL READING THERMOMETER B.2000			
80	TERMOSTATO 077B0437 DANFOSS	1	0225093	
	THERMOSTAT 077B0437 DANFOSS			
	STAFFA TERMOSTATO 077B0529	1	0225094	
	THERMOSTAT SUPPORT 077B0529			
81	TIMER D9444L-1 115/60 U.L.	1	3301996	
	TIMER D9444L-1 115/60 U.L.			
82	TRASFORMATORE 200VA 115/230 UL	1	0228031	
	ISOLATION TRANSFORMER 200VA 115/230 UL			
83	VALVOLA IN SERIE BIANCA	2	0444000	
	INLET AIR WHITE PLASTIC VALVE			

*Model STAR 55 MR IARP USA code 9254006*

**GENERAL LIST**

<b>Ref.</b>	<b>Description</b>	<b>Qty</b>	<b>Code</b>	<b>Price ITL</b>
84	VALVOLA SOLEVR3 115/60 U.L.	1	0189033	
	CUT OFF VALVE EVR3 115/60 UL			
85	VASCHETTA ABS MM260X100X80	1	0425009	
	ABS WATER TRAY mm 260X100X80			
86	PORTAFUSIBILI SEZIONABILE U.L.	1	3301811	
	FUSE HOLDER UL			
	FUSIBILE FNQ20 10X38 20A	2	3301812	
FUSE FNQ20 10X38 20A				
88	PRESSOSTATO G60P1221.600 B.PR. 0/1,2 BAR	1	0189034	
	PRESSOSTAT G60P1221.600 LOW PR. 0/1,2 BAR			

**Model STAR 55 MR Nestlè USA cod. 9254007**

**GENERAL LIST**

Ref.	Description	Qty	Code	Price ITL
1	BLOCCO CHIUS.B.TORS.MM1150	1	3302075	
	TORSION BAR CLOSING SYSTEM			
	VITE 4,2X 16 TSP+ZINCATA	1	0511030	
ZINC REAMED SCREW 4,2X16				
2	CABL. BOBINA VALVOLA SOL.EVR3	1	3601509	
	SOLENOID COIL FOR DEFROSTING VALVE EVR3			
3	BOCCOLA CERN.INF.BIANCA	1	3302071	
	DOOR LOWER PLASTIC BUSH			
	VITE 4,2X 16 TSP+ZINCATA	1	0511030	
	ZINC REAMED SCREW 4,2X16			
4	BOCCOLA T-J SERIES ASPERA	4	0534015	
	COMPRESSOR BUSH T-J SERIES ASPERA			
5	CABL.KLIXON F.SBRINAMENTO	1	3600437	
	END OF DEFROSTING THERMOSTAT			
6	CANOTTO DREN.A GOMITO EIS/VFP	1	0543075	
	PLASTIC TOGGLE JOINT EIS/VFP			
7	CANOTTO DREN.EVAP.EIS34	1	0543041	
	EVAPORATOR PLASTIC DRAINING TUBE			
8	CARTER EVAP.EIS32 ABS BIANCO	1	3700042	
	WHITW ABS EVAPORATOR COVER			
9	CASS.STAR34 ABS VER.ORO	1	0440247	
	ABS DISPLAY GOLD FRAME FOR STAR MODEL			
10	CAVO SPINA 3X1,5 MM2500 USA	1	3300799	
	POWER CORD WITH USA PLUG 3X1,5 MM2500			
11	CERN.SUP.ZAMA GREZZA DX	1	0415134	
	UPPER RIGHT DOOR HINGE			
12	COMPR.T2178GK 115/60 CSR	1	0210146	
	COMPR.T2178GK 115/60 CSR			
	RELAY GE 3ARR 3B3P3	1	0210330	
	RELAY GE 3ARR 3B3P3			
13	COND.DI MARCIA 25 MF 450V	1	0210424	
	RUN CAPACITOR 25 microF 450V			
	COND.DI SPUNTO 145/174 MF 165V	1	0210457	
	START CAPACITOR 145/174 microF 165V			
14	CONDENS.ALETT.36T.EIS55 U.L.	1	0130076	
	FINNED CONDENSER 36 TUBES UL			
15	COP.ABS TUBI POST.EIS 34	1	3700089	
	REAR PIPING INSULATED PLASTIC COVER			
16	CREM.AX/AB500/EC/EF/VFP50TRAN.	4	160372	
	STAINLESS STEEL RAIL FOR SELH SUPPORTS			
17	CRICCHETTO MINI LATHC C/SMUSSO	1	0202075	
	DRAINING TUBE STOPPER COUPLING			
18	CRUSCOTTO STAR ABS BLU P.300C	1	0411103	
	BLUE ABS CONTROLS SUPPORT FOR STAR MOD.			
19	DISTANZ.NYLON TUBO INOX	5	0544003	
	HOT PIPE SPACER			
20	EVAP ALETT.20TUBI EIS34 R 1V	1	0119136	
	FINNED EVAPORATOR 20 TUBES			

**Model STAR 55 MR Nestlè USA cod. 9254007**

**GENERAL LIST**

Ref.	Description	Qty	Code	Price ITL
21	FILTRO CARTUCCIA SOLIDA DN032	1	0145031	
	SOLID CORE DRYER DN032			
22	FILTRO RF 20DKBG5 115/250V 20A	1	3301671	
	EMC FILTER 20DKBG5 115/250V 20A			
23	GOMMINO AMMORT.D.24X6 NERO	4	0403007	
	COND. MOTOR FAN BLACK DUMPER FOOT 24X6mm			
24	GOMMINO AMMORT.D.24X6 NEUTRO	4	0403012	
	EVAP. MOTORFAN TRANS. DUMPER FOOT 24X6mm			
25	GOMMINO T-J SERIES ASPERA	4	0403021	
	COMPRESSOR DUMPER FOOT T-J SERIES ASPERA			
26	GRIGLIA ANT.STAR ABS BLU 300C	1	0427485	
	FRONT ABS BLUE GRILL			
27	GRIGLIA INTERNA VFP50/EIS34	1	0427079	
	STAR 55 SHELF SPACER REAR GRILL			
28	GRIGLIA MOTOVENTOLA INT. ABS	1	0427171	
	EVAPORATOR MOTORFAN ABS COVER GRILL			
29	GRIGLIA POST.EIS34/STAR34 NERA	1	0427407	
	STAR55 COMPR. OPENING REAR COVER GRILL			
30	GUARN.MAGN.EIS/VFP50/STAR	1	0313010	
	STAR55 DOOR BLACK MAGNETIC GASKET			
31	INTERR.BIP.LUM.VERDE ROTONDO	1	0202026	
	MAIN BIPOLAR ROUND SWITCH GREEN LIGHTING			
32	INTERR.UNIP.ROT.C/SPIA INDIP.	1	0202027	
	LIGHT ROUND SWITCH WITH RED DEFR. LIGHT			
33	LAMPADA 13W D.16 MM 516 K54	1	0200051	
	13W o.d.16 mm DISPLAY LAMP K 54			
34	LAMPADA 36W D.26 MM1200 K54	2	0200048	
	36W o.d.26 mm INNER LAMP 435 K 54			
35	MANIGLIA GIADA POSTERIORE	2	0400077	Non Presente
	REAR HANDLE MODEL GIADA			
36	MICROINT.VMN15S03C0	1	0202028	
	DOOR MICROSWITCH VMN15S03C0			
37	MORSETTIERA PA84 E SERRACAVO	1	0001012	
	PA84E TERMINAL BOARD WITH STRAIN RELIEF			
38	MOTORE 16W30 T3 115/60 UL C500	1	0220079	
	COND. MOTOR FAN 16W30 T3 115/60 UL C500			
	STAFFA MOTOV.TIPO B DIR.H.72			
39	MOTORE 9W20 T1 115/60 UL C1200	1	0220077	
	EVAP. MOTOR FAN 9W20 T1 115/60 UL C1200			
40	PALA ALLUMINIO A 200-28	1	0407001	
	ALUMINIUM BLADE A 200-28			
41	PALA ALLUMINIO A 230-34	1	0407013	
	ALUMINIUM BLADE A 230-34			
42	PANN.CASS.STAR NESTLE'HDAZS	1	0340343	
	NESTLE H.DAZS DISPLAY PANEL			
43	PANN.CENTR.STAR DISPLAY	1	0411065	
	THERMOMETER PLASTIC COVER			

**Model STAR 55 MR Nestlè USA cod. 9254007**

**GENERAL LIST**

Ref.	Description	Qty	Code	Price ITL
44	PANN.CRUSC.ASTRA ABS BLU 300C	1	0440276	
	BLUE ABS CONTROL SUPPORT COVER			
45	PANN.INTERR.LINEA STAR	1	0411066	
	MAIN SWITCH PLASTIC COVER			
46	PIASTRINA BLOCCAGGIO CANOTTO	1	0543022	
	EVAPOR. DRAINING TUBE PLASTIC STOPPER			
47	PIEDINO ESAGONALE 10MAX43 R128	2	0403014	
	HEXAGONAL FOOT 10MAX43 R128			
48	POMELLO TER.ABS GRIGIO P.429C	1	0413010	
	THERMOSTAT GRAY ABS KNOB P. 429C			
49	PORTA STAR VERN.ORO U.L.C/MAN.	1	0070932	
	COMPLETE STAR55 GOLD DOOR			
50	PORTALAMPADA G5 109686 U.L.	2	3301891	
	LAMPHOLDER G5 109686 U.L.			
51	PORTALAMPADA 101784 U.L.	4	3301800	
	LAMPHOLDER G13 101784 U.L.			
52	PORTASTARTER 430 U.L.	3	3301794	
	STARTER HOLDER 430 UL			
53	PROF.POLIC.COPRILAMPADA STAR	1	0320339	
	DISPLAY LAMP COVER PROFILE FOR STAR MODEL			
54	PROF.POLIC.C431 MM1298	2	0320600	
	INNER LAMP COVER PROFILE C431 L.1298mm			
55	PROF.PVC VP1015 MM 661 NERO	2	0320232	
	BLACK PVC PROFILE VP1015 mm 661			
56	PROF.PVC VP1015 MM1418 NERO	2	0320344	
	BLACK PVC PROFILE VP1015 mm 1418			
57	PROLUNGA CANOTTO EIS30/GT D.17	1	0543000	
	"L" SHAPE DRAINING TUBE EIS 30/GT o.d. 17mm			
58	RACCORDERIA EV.ACQUA INOX	1	0160781	
	STAINLESS STEEL TUBE FOR WATER EVAPORAT.			
59	REATTORE 13W 120/60 HZ U.L.	1	3300611	
	BALLAST 13W 120/60 HZ U.L.			
60	REATTORE 40W 115/60 U.L.	2	3301806	
	BALLAST 40W 115/60 U.L.			
61	RELE'FINDER 6282-8-120-0006	1	3301890	
	DEFROSTING RELAY FINDER 6282-8-120-0006			
62	RELE'G7L-1A-TUB 120VCA	1	3300708	
	COMPR. RELAY G7L-1A-TUB 120VCA			
63	RELE'G7L-2A-TUB 120VCA	1	3301807	
	MAIN RELAY G7L-2A-TUB 120VCA			
64	RESISTENZA 10W/MT 230V TELAIO	1	3301813	
	DOOR FRAME HEATER 10W/m 230V			
65	RESISTENZA 20W/MT EIS/STAR 45	1	0205315	
	EVAP. GUTTER HEATER 20W/m 115V EIS/STAR 55			
66	RES. COR. INOX 500W EVAPORATORE	1	0205301	
	EVAPOR. HEATER 500W			
67	RIPIANO DI FONDO VFP 50	1	0427077	
	BOTTOM SHELF			

**Model STAR 55 MR Nestlè USA cod. 9254007**

**GENERAL LIST**

Ref.	Description	Qty	Code	Price ITL
68	RIPIANO VASCA VFP50/EIS 55	4	0427078	
	TANK SHELF			
69	RULLINO NYLON D.23 MM 38	4	0402000	
	NYLON ROLLER o.d. 23 mm l. 38 mm			
	DADO 6MA AUTOBLOCCANTE	4	0505004	
	SELFLOCKING NUT 6MA			
	PERNO D.7 FIL. M6 MM 55	4	0530013	
	PIVOT o.d. 7 mm M6 l. 55mm			
70	SACCHETTO N°16 GANCI SUPP.RIP.	1	0160741	
	16 SELF SUPPORTS			
71	SCATOLA VALVOLE SCARICO ACQUA	1	0425000	
	WATER DISCHARGE BOX			
	PALLA D.38 PER SCARICO ACQUA	1	0426000	
	BALL o.d. 38 mm FOR WATER DISCHARGE			
72	SGOCCIOL.EIS 34 M.RES.L.ZN.	1	3601666	
	EVAPOR. ZINC COATED GUTTER EIS 34			
	COP.SCARICO SGOCC.EIS34 L.ZN.	1	3601665	
	DRAINING TUBE ZINC COATED STEEL SHEET			
	RINF.SGOCCIOL.EIS 32/34 L. ZN	1	7072534	
	GUTTER REINFORCEMENT			
	STAFFA SGOCCIOL.EIS 34 1V L.ZN	1	3601664	
GUTTER SUPPORT				
73	STARTER FS11 4/80W 220V U.L.	3	0207012	
	STARTER FS11 4/80W 220V U.L.			
74	SUPP.BULBO TERMOM./TERMOS.ABS	1	0542048	
	THERMOM. THERMOSTAT PLASTIC SUPPORT			
75	SUPP.INF.PORTA STAR M RES.NERO	1	0162584	
	DOOR FRAME SUPPORT			
76	FLANGIA PER TAPPO CANOTTO ABS	1	0312299	
	TANK ABS DRAINING TUBE			
	TAPPO CANOTTO ASTRA ABS BLU	1	0312004	
	TANK ABS DRAINING TUBE BLUE STOPPER			
77	TAPPO COPRIVITE ASTRA/STAR	2	3300061	
	DOOR SCREW COVER STAR 55			
78	TAPPO DREN.INTERNO NEUTRO	1	0312038	
	INNER DRAINING TUBE STOPPER			
79	TERMOMETRO LETT.OR.B2000 NERO	1	0406036	
	HORIZONTAL READING THERMOMETER B.2000			
80	TERMOSTATO 077B0437 DANFOSS	1	0225093	
	THERMOSTAT 077B0437 DANFOSS			
	STAFFA TERMOSTATO 077B0529	1	0225094	
	THERMOSTAT SUPPORT 077B0529			
81	TIMER D9444L-1 115/60 U.L.	1	3301996	
	TIMER D9444L-1 115/60 U.L.			
82	TRASFORMATORE 200VA 115/230 UL	1	0228031	
	ISOLATION TRANSFORMER 200VA 115/230 UL			
83	VALVOLA IN SERIE BIANCA	2	0444000	
	INLET AIR WHITE PLASTIC VALVE			

*Model STAR 55 MR Nestlè USA cod. 9254007*

**GENERAL LIST**

<b>Ref.</b>	<b>Description</b>	<b>Qty</b>	<b>Code</b>	<b>Price ITL</b>
84	VALVOLA SOL.EVR3 115/60 U.L.	1	0189033	
	CUT OFF VALVE EVR3 115/60 UL			
85	VASCHETTA ABS MM260X100X80	1	0425009	
	ABS WATER TRAY mm 260X100X80			
88	PRESSOSTATO G60P1221.600 B.PR. 0/1,2 BAR	1	0189034	
	PRESSOSTAT G60P1221.600 LOW PR. 0/1,2 BAR			

**GENERAL LIST**

Ref.	Description	Qty	Code	Price IFL
1	BLOCCO CHIUS.B.TORS.MM1150	1	3302075	
	TORSION BAR CLOSING SYSTEM			
	VITE 4,2X 16 TSP+ZINCATA	1	0511030	
ZINC REAMED SCREW 4,2X16				
2	CABL. BOBINA VALVOLA SOLEVR3	1	3601509	
	SOLENOID COIL FOR DEFROSTING VALVE EVR3			
3	BOCCOLA CERN.INF.BIANCA	1	3302071	
	DOOR LOWER PLASTIC BUSH			
	VITE 4,2X 16 TSP+ZINCATA	1	0511030	
	ZINC REAMED SCREW 4,2X16			
4	BOCCOLA T-J SERIES ASPERA	4	0534015	
	COMPRESSOR BUSH T-J SERIES ASPERA			
5	CABL.KLIXON F.SBRINAMENTO	1	3600437	
	END OF DEFROSTING THERMOSTAT			
6	CANOTTO DREN.A GOMITO EIS/VFP	1	0543075	
	PLASTIC TOGGLE JOINT EIS/VFP			
7	CANOTTO DREN.EVAP.EIS34	1	0543041	
	EVAPORATOR PLASTIC DRAINING TUBE			
8	CARTER EVAP.EIS32 ABS BIANCO	1	3700042	
	WHITW ABS EVAPORATOR COVER			
9	CASS.STAR34 ABS VER.ORO	1	0440247	
	ABS DISPLAY GOLD FRAME FOR STAR MODEL			
10	CAVO SPINA 3X1,5 MM2500 USA	1	3300799	
	POWER CORD WITH USA PLUG 3X1,5 MM2500			
11	CERN.SUP.ZAMA GREZZA DX	1	0415134	
	UPPER RIGHT DOOR HINGE			
12	COMPR.T2178GK 115/60 CSR	1	0210146	
	COMPR.T2178GK 115/60 CSR			
	RELAY GE 3ARR 3B3P3	1	0210330	
	RELAY GE 3ARR 3B3P3			
13	COND.DI MARCIA 25 MF 450V	1	0210424	
	RUN CAPACITOR 25 microF 450V			
	COND.DI SPUNTO 145/174 MF 165V	1	0210457	
	START CAPACITOR 145/174 microF 165V			
14	CONDENS.ALETT.36T.EIS55 U.L.	1	0130076	
	FINNED CONDENSER 36 TUBES UL			
15	COP.ABS TUBI POST.EIS 34	1	3700089	
	REAR PIPING INSULATED PLASTIC COVER			
16	CREM.AX/AB500/EC/EF/VFP50TRAN.	4	160372	
	STAINLESS STEEL RAIL FOR SELH SUPPORTS			
17	CRICCHETTO MINI LATHC C/SMUSSO	1	0202075	
	DRAINING TUBE STOPPER COUPLING			
18	CRUSCOTTO STAR ABS BLU P.300C	1	0411103	
	BLUE ABS CONTROLS SUPPORT FOR STAR MOD.			
19	DISTANZ.NYLON TUBO INOX	5	0544003	
	HOT PIPE SPACER			
20	EVAP ALETT.20TUBI EIS34 R 1V	1	0119136	
	FINNED EVAPORATOR 20 TUBES			

**Model STAR 55 MR Nestlè USA cod. 9254009**

**GENERAL LIST**

Ref.	Description	Qty	Code	Price IFL
21	FILTRO CARTUCCIA SOLIDA DN032	1	0145031	
	SOLID CORE DRYER DN032			
22	FILTRO RF 20DKBG5 115/250V 20A	1	3301671	
	EMC FILTER 20DKBG5 115/250V 20A			
23	GOMMINO AMMORT.D.24X6 NERO	4	0403007	
	COND. MOTOR FAN BLACK DUMPER FOOT 24X6mm			
24	GOMMINO AMMORT.D.24X6 NEUTRO	4	0403012	
	EVAP. MOTORFAN TRANS. DUMPER FOOT 24X6mm			
25	GOMMINO T-J SERIES ASPERA	4	0403021	
	COMPRESSOR DUMPER FOOT T-J SERIES ASPERA			
26	GRIGLIA ANT.STAR ABS BLU 300C	1	0427485	
	FRONT ABS BLUE GRILL			
27	GRIGLIA INTERNA VFP50/EIS34	1	0427079	
	STAR 55 SHELF SPACER REAR GRILL			
28	GRIGLIA MOTOVENTOLA INT. ABS	1	0427171	
	EVAPORATOR MOTORFAN ABS COVER GRILL			
29	GRIGLIA POST.EIS34/STAR34 NERA	1	0427407	
	STAR55 COMPR. OPENING REAR COVER GRILL			
30	GUARN.MAGN.EIS/VFP50/STAR	1	0313010	
	STAR55 DOOR BLACK MAGNETIC GASKET			
31	INTERR.BIP.LUM.VERDE ROTONDO	1	0202026	
	MAIN BIPOLAR ROUND SWITCH GREEN LIGHTING			
32	INTERR.UNIP.ROT.C/SPIA INDIP.	1	0202027	
	LIGHT ROUND SWITCH WITH RED DEFR. LIGHT			
33	LAMPADA 13W D.16 MM 516 K54	1	0200051	
	13W o.d.16 mm DISPLAY LAMP K 54			
34	LAMPADA 36W D.26 MM1200 K54	2	0200048	
	36W o.d.26 mm INNER LAMP 435 K 54			
35	MANIGLIA GIADA POSTERIORE	2	0400077	Non Presente
	REAR HANDLE MODEL GIADA			
36	MICROINT.VMN15S03C0	1	0202028	
	DOOR MICROSWITCH VMN15S03C0			
37	MORSETTIERA PA84 E SERRACAPO	1	0001012	
	PA84E TERMINAL BOARD WITH STRAIN RELIEF			
38	MOTORE 16W30 T3 115/60 UL C500	1	0220079	
	COND. MOTOR FAN 16W30 T3 115/60 UL C500			
	STAFFA MOTOV.TIPO B DIR.H.72			
39	MOTORE 9W20 T1 115/60 UL C1200	1	0220077	
	EVAP. MOTOR FAN 9W20 T1 115/60 UL C1200			
40	PALA ALLUMINIO A 200-28	1	0407001	
	ALUMINIUM BLADE A 200-28			
41	PALA ALLUMINIO A 230-34	1	0407013	
	ALUMINIUM BLADE A 230-34			
42	PANN.CASS.STAR NESTLE'HDAZS	1	0340343	
	NESTLE H.DAZS DISPLAY PANEL			
43	PANN.CENTR.STAR DISPLAY	1	0411065	
	THERMOMETER PLASTIC COVER			

**Model STAR 55 MR Nestlè USA cod. 9254009**

**GENERAL LIST**

Ref.	Description	Qty	Code	Price ITL
44	PANN.CRUSC.ASTRA ABS BLU 300C	1	0440276	
	BLUE ABS CONTROL SUPPORT COVER			
45	PANN.INTERR.LINEA STAR	1	0411066	
	MAIN SWITCH PLASTIC COVER			
46	PIASTRINA BLOCCAGGIO CANOTTO	1	0543022	
	EVAPOR. DRAINING TUBE PLASTIC STOPPER			
47	PIEDINO ESAGONALE 10MAX43 R128	2	0403014	
	HEXAGONAL FOOT 10MAX43 R128			
48	POMELLO TER.ABS GRIGIO P.429C	1	0413010	
	THERMOSTAT GRAY ABS KNOB P. 429C			
49	PORTA STAR VERN.ORO U.L.C/chiusura	1	0070974	
	COMPLETE STAR55 GOLD DOOR WITH LOCK			
50	PORTALAMPADA G5 109686 U.L.	2	3301891	
	LAMPHOLDER G5 109686 U.L.			
51	PORTALAMPADA 101784 U.L.	4	3301800	
	LAMPHOLDER G13 101784 U.L.			
52	PORTASTARTER 430 U.L.	3	3301794	
	STARTER HOLDER 430 UL			
53	PROF.POLIC.COPRILAMPADA STAR	1	0320339	
	DISPLAY LAMP COVER PROFILE FOR STAR MODEL			
54	PROF.POLIC.C431 MM1298	2	0320600	
	INNER LAMP COVER PROFILE C431 L.1298mm			
55	PROF.PVC VP1015 MM 661 NERO	2	0320232	
	BLACK PVC PROFILE VP1015 mm 661			
56	PROF.PVC VP1015 MM1418 NERO	2	0320344	
	BLACK PVC PROFILE VP1015 mm 1418			
57	PROLUNGA CANOTTO EIS30/GT D.17	1	0543000	
	"L" SHAPE DRAINING TUBE EIS 30/GT o.d. 17mm			
58	RACCORDERIA EV.ACQUA INOX	1	0160781	
	STAINLESS STEEL TUBE FOR WATER EVAPORAT.			
59	REATTORE 13W 120/60 HZ U.L.	1	3300611	
	BALLAST 13W 120/60 HZ U.L.			
60	REATTORE 40W 115/60 U.L.	2	3301806	
	BALLAST 40W 115/60 U.L.			
61	RELE'FINDER 6282-8-120-0006	1	3301890	
	DEFROSTING RELAY FINDER 6282-8-120-0006			
62	RELE'G7L-1A-TUB 120VCA	1	3300708	
	COMPR. RELAY G7L-1A-TUB 120VCA			
63	RELE'G7L-2A-TUB 120VCA	1	3301807	
	MAIN RELAY G7L-2A-TUB 120VCA			
64	RESISTENZA 10W/MT 230V TELAIO	1	3301813	
	DOOR FRAME HEATER 10W/m 230V			
65	RESISTENZA 20W/MT EIS/STAR 45	1	0205315	
	EVAP. GUTTER HEATER 20W/m 115V EIS/STAR 55			
66	RES. COR. INOX 500W EVAPORATORE	1	0205301	
	EVAPOR. HEATER 500W			
67	RIPIANO DI FONDO VFP 50	1	0427077	
	BOTTOM SHELF			

**Model STAR 55 MR Nestlè USA cod. 9254009**

**GENERAL LIST**

Ref.	Description	Qty	Code	Price ITL
68	RIPIANO VASCA VFP50/EIS 55	4	0427078	
	TANK SHELF			
69	RULLINO NYLON D.23 MM 38	4	0402000	
	NYLON ROLLER o.d. 23 mm l. 38 mm			
	DADO 6MA AUTOBLOCCANTE	4	0505004	
	SELFLOCKING NUT 6MA			
	PERNO D.7 FIL. M6 MM 55	4	0530013	
	PIVOT o.d. 7 mm M6 l. 55mm			
70	SACCHETTO N°16 GANCI SUPP.RIP.	1	0160741	
	16 SELF SUPPORTS			
71	SCATOLA VALVOLE SCARICO ACQUA	1	0425000	
	WATER DISCHARGE BOX			
	PALLA D.38 PER SCARICO ACQUA	1	0426000	
	BALL o.d. 38 mm FOR WATER DISCHARGE			
72	SGOCCIOL.EIS 34 M.RES.L.ZN.	1	3601666	
	EVAPOR. ZINC COATED GUTTER EIS 34			
	COP.SCARICO SGOCC.EIS34 L.ZN.	1	3601665	
	DRAINING TUBE ZINC COATED STEEL SHEET			
	RINF.SGOCCIOL.EIS 32/34 L. ZN	1	7072534	
	GUTTER REINFORCEMENT			
	STAFFA SGOCCIOL.EIS 34 1V L.ZN	1	3601664	
	GUTTER SUPPORT			
73	STARTER FS11 4/80W 220V U.L.	3	0207012	
	STARTER FS11 4/80W 220V U.L.			
74	SUPP.BULBO TERMOM./TERMOS.ABS	1	0542048	
	THERMOM. THERMOSTAT PLASTIC SUPPORT			
75	SUPP.INF.PORTA STAR M RES.NERO	1	0162584	
	DOOR FRAME SUPPORT			
76	FLANGIA PER TAPPO CANOTTO ABS	1	0312299	
	TANK ABS DRAINING TUBE			
	TAPPO CANOTTO ASTRA ABS BLU	1	0312004	
	TANK ABS DRAINING TUBE BLUE STOPPER			
77	TAPPO COPRIVITE ASTRA/STAR	2	3300061	
	DOOR SCREW COVER STAR 55			
78	TAPPO DREN.INTERNO NEUTRO	1	0312038	
	INNER DRAINING TUBE STOPPER			
79	TERMOMETRO LETT.OR.B2000 NERO	1	0406036	
	HORIZONTAL READING THERMOMETER B.2000			
80	TERMOSTATO 077B0437 DANFOSS	1	0225093	
	THERMOSTAT 077B0437 DANFOSS			
	STAFFA TERMOSTATO 077B0529	1	0225094	
	THERMOSTAT SUPPORT 077B0529			
81	TIMER D9444L-1 115/60 U.L.	1	3301996	
	TIMER D9444L-1 115/60 U.L.			
82	TRASFORMATORE 200VA 115/230 UL	1	0228031	
	ISOLATION TRANSFORMER 200VA 115/230 UL			
83	VALVOLA IN SERIE BIANCA	2	0444000	
	INLET AIR WHITE PLASTIC VALVE			

*Model STAR 55 MR Nestlè USA cod. 9254009*

**GENERAL LIST**

<b>Ref.</b>	<b>Description</b>	<b>Qty</b>	<b>Code</b>	<b>Price ITL</b>
84	VALVOLA SOL.EVR3 115/60 U.L.	1	0189033	
	CUT OFF VALVE EVR3 115/60 UL			
85	VASCHETTA ABS MM260X100X80	1	0425009	
	ABS WATER TRAY mm 260X100X80			
88	PRESSOSTATO G60P1221.600 B.PR. 0/1,2 BAR	1	0189034	
	PRESSOSTAT G60P1221.600 LOW PR. 0/1,2 BAR			