

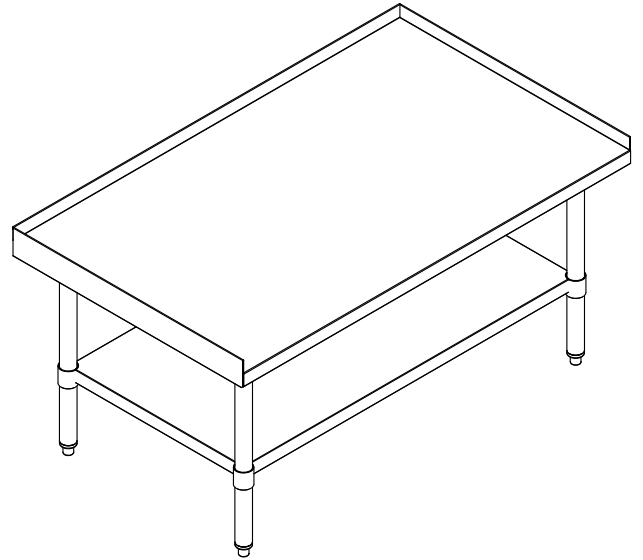

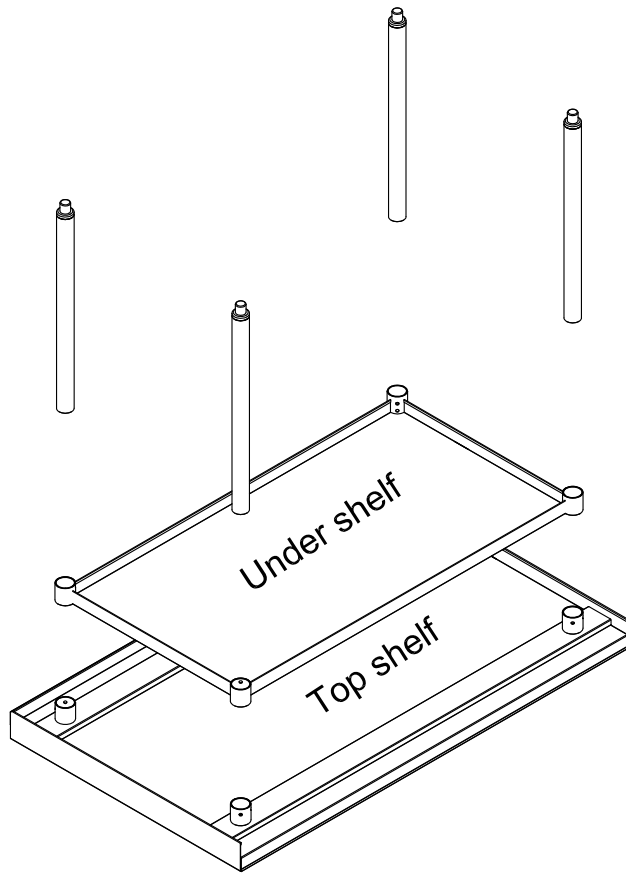

# Equipment Stand With 4 Legs Assemble Instruction

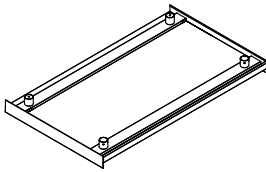
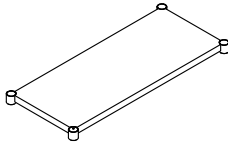

Main parts			
No.	Pattern	Part name	QTY
1		Top shelf	1
2		Under shelf	1
3		Leg	4

Accessories			
No.	Pattern	Part name	Quantity
①		M8*1*8 Screws	17
②		S4 Screw Wrench	1

①

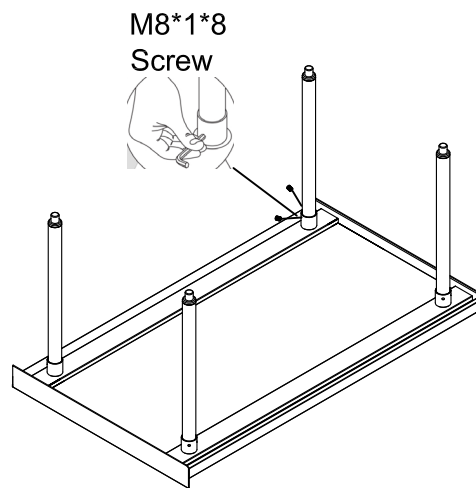
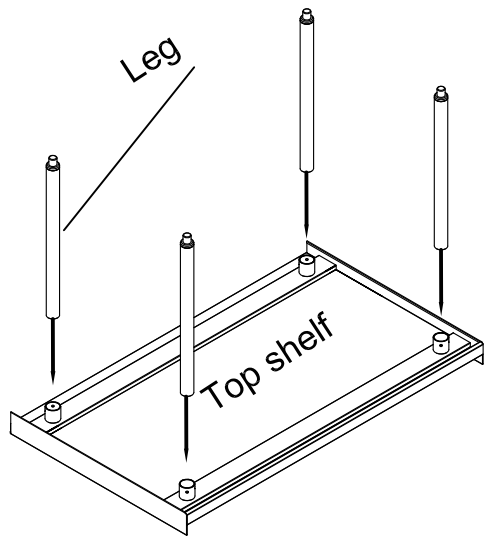

Turn the top shelf upside down onto the floor, Insert four legs into the leg sockets, then partially fasten the allen screws

②

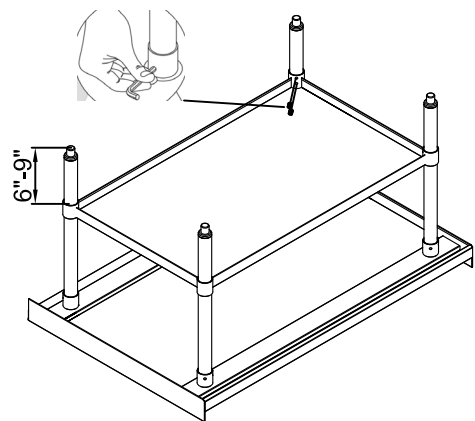
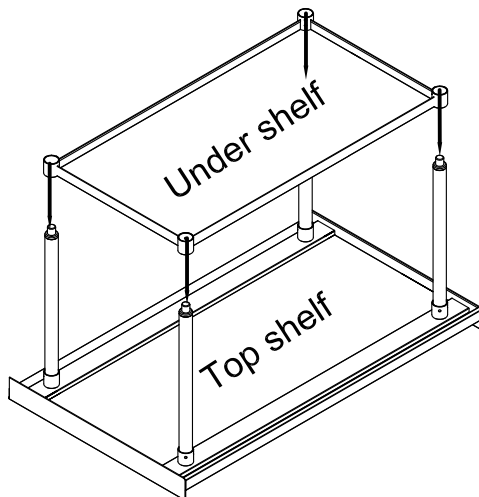

Slide the lower shelf into four legs to desired height(the distance from the bottom of the leg to the shelf is 6"-9"), then tighten all allen crews to secure the lower shelf in place, tighten the screws on the top shelf.

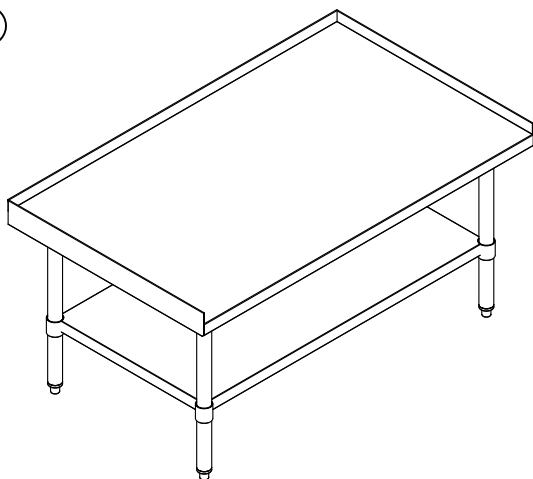

③



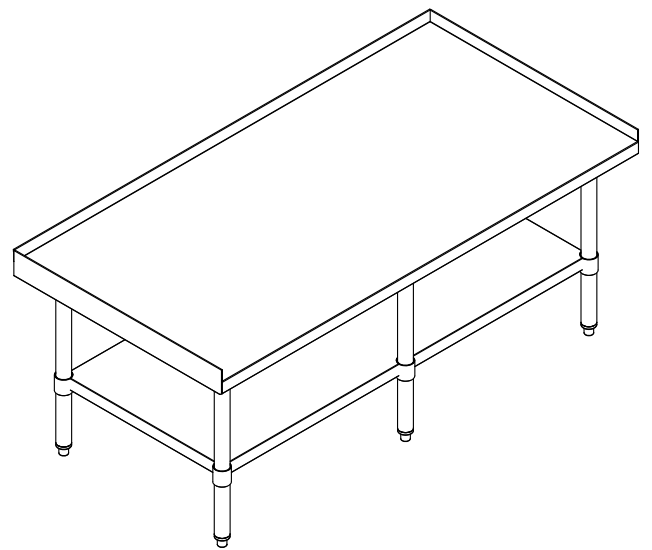
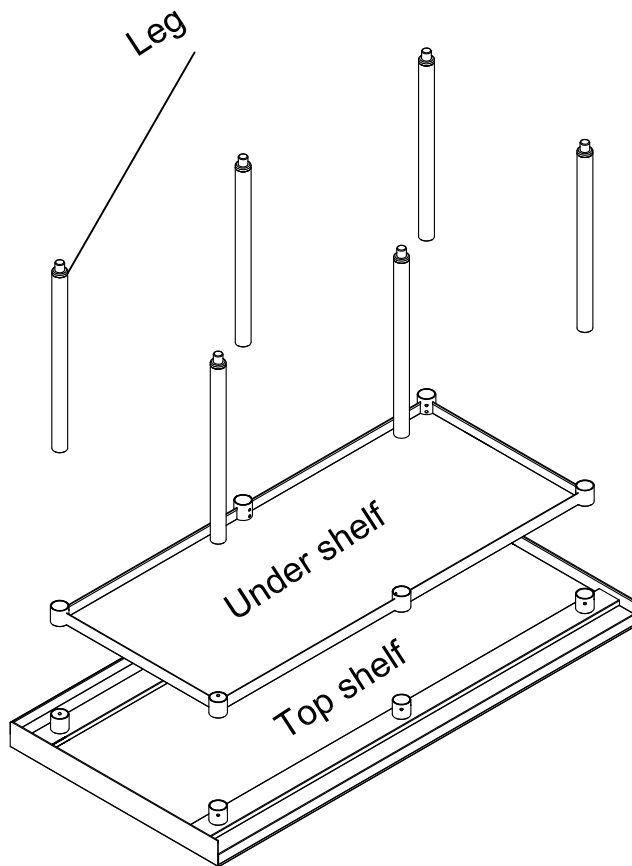

Turn over the assembled equipment stand , adjust the feet height to ensure proper leveling and stability, your equipment stand is now ready to use

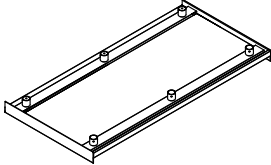
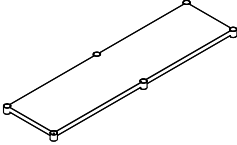
# Equipment Stand With 6 Legs Assemble Instruction



Main parts			
No.	Pattern	Part name	QTY
1		Top shelf	1
2		Under shelf	1
3		Leg	6

Accessories			
No.	Pattern	Part name	QTY
①		M8*1*8 Screws	25
②		S4 Screw Wrench	1

