

Owner's Manual

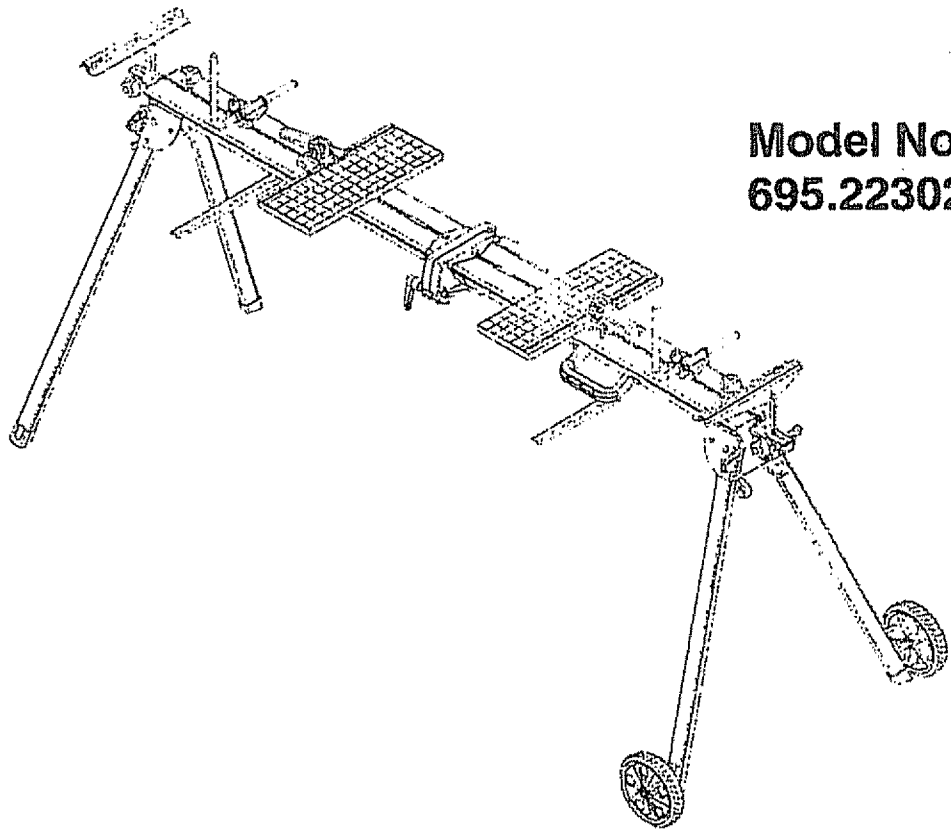

Universal Miter Saw Stand



Model No.
695.22302

WARNING: Read, understand and follow all rules and instructions in this manual **BEFORE** using this product. Failure to do so can result in serious personal injury.

Sears, Roebuck and Co.,
Hoffman Estates,
IL 60179 U.S.A.

- WARRANTY
- SAFETY
- ASSEMBLY
- FEATURES
- STORAGE
- REPAIR PARTS

TABLE OF CONTENTS

Warranty.....	Page	2
Safety Instructions.....	Pages	3 - 5
Description, Specifications.....	Page	6
Unpacking, Carton Contents.....	Pages	7 - 9
Assembly.....	Pages	10 - 27
Miter Saw Compatibility.....	Page	28
Mounting Other Tools.....	Page	29
Usage.....	Page	30 - 32
Storage.....	Pages	33
Repair Parts.....	Pages	34 - 35

ONE-YEAR FULL WARRANTY ON CRAFTSMAN PROFESSIONAL UNIVERSAL MITER SAW STAND

If this **CRAFTSMAN PROFESSIONAL** product fails due to a defect in material or workmanship within one year from the date of purchase, **RETURN IT TO ANY SEARS STORE OR OTHER CRAFTSMAN OUTLET IN THE UNITED STATES FOR FREE REPLACEMENT.**

This warranty gives you specific legal rights, and you may also have other rights which vary from state to state.

Sears, Roebuck and Co., Dept. 817WA, Hoffman Estates, IL 60179

MITER SAW STAND SAFETY RULES

1. **DO NOT** stand or climb on miter saw stand. It could tip over causing serious injury.
2. **BE SURE** all locking pins are in the set-up position holes **BEFORE** using your miter saw and miter saw stand.
3. **ALWAYS** firmly attach miter saw. **DO NOT** attempt to use your miter saw stand until the miter saw is fastened firmly to the boards.
4. **ONLY** use your miter saw stand on a hard, dry, flat, and level surface.
5. **BE SURE** that any bench top tool used with this stand is firmly attached to the boards.
6. **BE SURE** the board clamps are tightly clamped to the stand when the bench top tool is in use.
7. **ALWAYS** keep all guards in place. **BE SURE** all power tool guards are in good working order and are in proper adjustment
8. **ALWAYS** keep your hands away from the cutting area.
9. **DO NOT** mount a table saw onto this stand. The direction of feed on a table saw is counter to the axis of best stability on this stand. Aggressive feeding of sheet materials into a table saw could cause the stand to tip.
10. **ALWAYS** use clamps or a vise to hold work when practical. Using clamps or a vise to hold work is safer than using your hand. It also frees both hands to operate the saw.

GENERAL SAFETY RULES

⚠ WARNING: **BE SURE** to read and understand all instructions in this manual and the miter saw's operating manual before using it on the stand. Failure to follow all instructions can result in electric shock, fire and/or serious personal injury.

WORK AREA SAFETY

1. **ALWAYS** keep your work area clean and well lit. Cluttered benches and dark areas invite accidents.
2. **DO NOT** operate power tools in explosive atmospheres, such as in the presence of flammable liquids, gases, or dust. Power tools create sparks that may ignite the dust or fumes.
3. **ALWAYS** keep bystanders, children, and visitors away while operating a power tool. Distractions can cause you to lose control.

GENERAL SAFETY RULES

ELECTRICAL SAFETY

1. Double insulated tools are equipped with a polarized plug (one blade is wider than the other). This plug will fit in a polarized outlet only one way. If the plug does not fit fully into the outlet, reverse the plug. If it still does not fit, contact a qualified electrician to install a polarized outlet. **DO NOT** change or alter the plug in any way.
2. Double insulation eliminates the need for the three-wire grounded power cord and grounded power supply system. Applicable only to Class II (double insulated) tools.
3. Before plugging in the tool, **BE SURE** that the outlet voltage supplied is within the voltage marked on the tool's data plate. **DO NOT** use "AC only" rated tools with a DC power supply.
4. **ALWAYS** avoid body contact with grounded surfaces, such as pipes, radiators, ranges and refrigerators. There is an increased risk of electric shock if your body is grounded.
5. If operating the power tool in damp locations is unavoidable, **ALWAYS** use a Ground Fault Circuit Interrupter to supply power to your tool. **ALWAYS** wear electrician's rubber gloves and footwear in damp conditions.
6. **DO NOT** expose power tools to rain or wet conditions. Water entering a power tool will increase the risk of electric shock.
7. **DO NOT** abuse the cord. **NEVER** use the cord to carry the tools or pull the plug from the outlet. Keep cord away from heat, oil, sharp edges or moving parts. Replace damaged cords immediately. Damaged cords increase the risk of electric shock.
8. When operating a power tool outside, **ALWAYS** use an outdoor extension cord marked "W-A" or "W". These cords are rated for outdoor use and reduce the risk of electric shock.

NOTE: The extension cord must have adequate wire size AWG (American Wire Gauge) for safe, efficient use. Smaller gauge wires, have greater capacity (16 gauge wire has more capacity than 18 gauge wire).

PERSONAL SAFETY

1. **ALWAYS** stay alert, watch what you are doing, and use common sense when operating a power tool. **DO NOT** use tool while tired or under the influence of drugs, alcohol or medication. A moment of inattention while operating power tools may result in serious personal injury.
2. **ALWAYS** dress properly. **DO NOT** wear loose clothing or jewelry. Pull back long hair. Keep your hair, clothing, and gloves away from moving parts. Loose clothing, jewelry, or long hair can be caught in moving parts.
3. **ALWAYS** avoid accidental starting. **BE SURE** switch is in the "Off" position before plugging in. Do not carry tools with your finger on the switch. Carrying tools with your finger on the switch or plugging in tools that have the switch in the "On" position invites accidents.

GENERAL SAFETY RULES (cont.)

PERSONAL SAFETY (cont.)

4. **ALWAYS** remove adjusting keys or wrenches before turning the tool on. A wrench or a key that is left attached to a rotating part of the tool may result in personal injury.
5. **DO NOT** overreach. **ALWAYS** keep proper footing and balance at all times. Proper footing and balance enables better control of the tool in unexpected situations.
6. **ALWAYS** use safety equipment. Always wear eye protection. Dust mask, non-skid safety shoes, hard hat, or hearing protection must be used for appropriate conditions

SAFE TOOL USE AND CARE

1. **ALWAYS** use clamps or other practical ways to secure and support the workpiece to a stable platform. Holding the work by hand or against your body is unstable and may lead to loss of control.
2. **DO NOT** force the tool. Use the correct tool for your application. The correct tool will do the job better and safer at the rate for which it is designed.
3. **DO NOT** use the tool if the switch does not turn it "On" or "Off". Any tool that cannot be controlled with the switch is dangerous and must be repaired.
4. **ALWAYS** disconnect the plug from the power source before making any adjustments, changing accessories, or storing the tool. Such preventive safety measures reduce the risk of starting the tool accidentally.
5. **ALWAYS** store idle tools out of the reach of children and other untrained persons. Tools are dangerous in the hands of untrained users.
6. **ALWAYS** maintain tools with care. Keep cutting tools sharp and clean. Properly maintained tools with sharp cutting edges are less likely to bind and are easier to control.
7. **ALWAYS** check for misalignment or binding of moving parts, breakage of parts, and any other condition that may affect the tool's operation. If damaged, have the tool serviced before using. Many accidents are caused by poorly maintained tools.

⚠ WARNING USE OF ACCESSORIES THAT ARE NOT RECOMMENDED FOR USE WITH YOUR TOOL MAY CREATE A HAZARDOUS CONDITION.

8. **ALWAYS** use only accessories that are recommended for your tool. Accessories that may be suitable for one tool can become hazardous when used on another tool.

DESCRIPTION

This Miter Saw Stand is designed with features that make using your miter saw more convenient. The Quick-jaw® clamp and mounting boards accommodate and secure most brands and sizes of miter saws. Telescoping support rails extend up to five feet left or right. Two adjustable work supports and stop/edge guides for accurate feed and cutting. Single knob adjustments for quick support and guide position settings. 7-inch wheels for portability. Stand supports up to 400 lbs. Positive-locking legs for extra stability. Folds easily for mobility or storage. See Figure 1.

Fig. 1

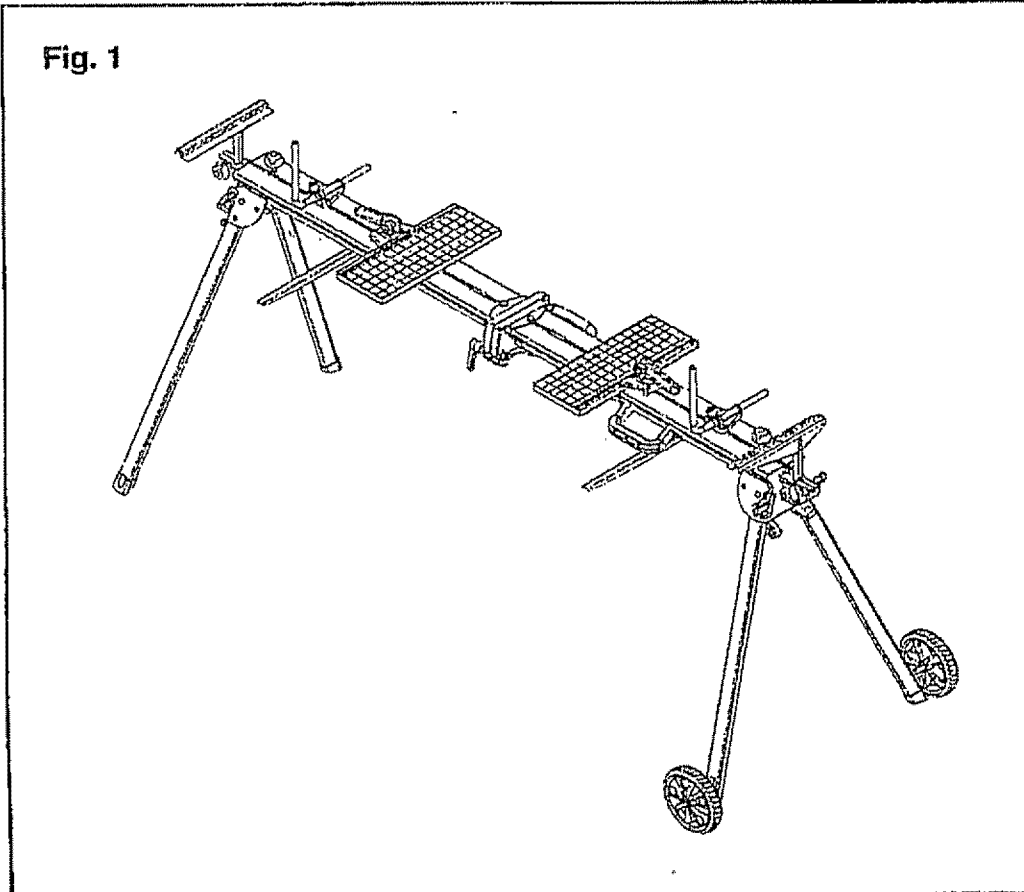

PRODUCT SPECIFICATIONS

Stand Dimensions

Folded.....	40 5/8-in. (L) x 24-in. (W) x 10-in. (H)
Extended.....	136-in. (L) x 33 5/8-in. (W) x 36-in. (H)
Weight (with no tool mounted).....	40 lbs.
Weight Capacity (center section).....	400 lbs.
Tabletop Height.....	34 in.
Wheel Diameter.....	7 in.

CARTON CONTENTS

UNPACKING

Unpack all parts and carefully separate parts from packing materials. Check each part with the parts illustration and list on pages 7, 8 and 9. **BE SURE** that all parts are accounted for before discarding any packing materials. To make assembly easier, keep the contents of the box together. Wipe parts thoroughly with a clean, dry cloth.

PACKAGE CONTENTS AND HARDWARE (Figure 2)

Item	Description	Quantity
A	Frame Assembly, including legs	1
B	Wheel Assembly	2
C	Mounting Board	2
D	Carrying Handle	1
E	Work Support Assembly, Right	1
F	Work Support Assembly, Left	1
G	Clamp Assembly	2
H	Edge Guide Assembly	2

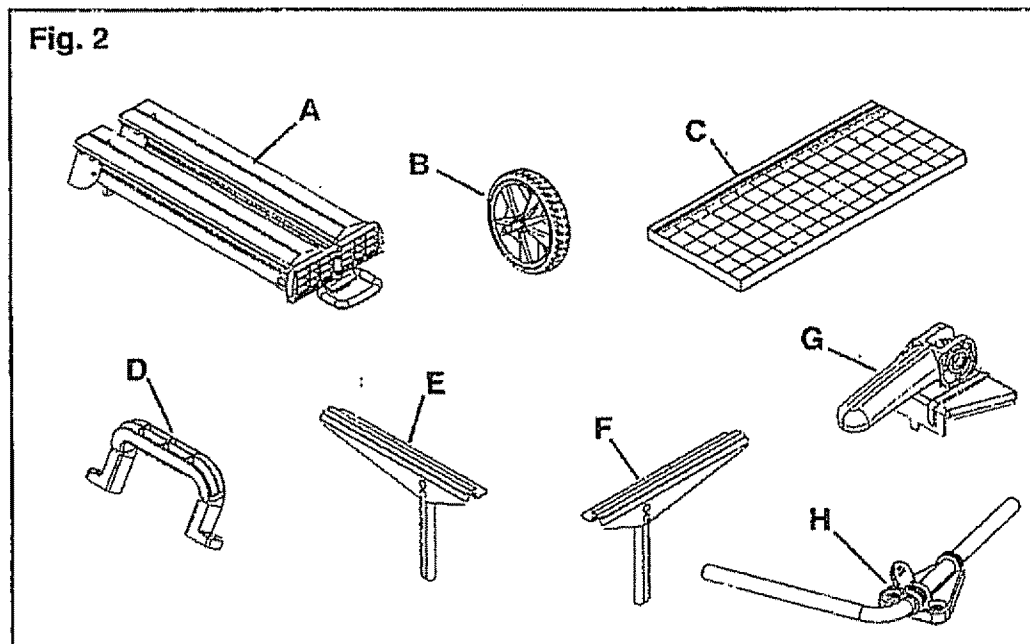

CARTON CONTENTS (cont.)**PACKAGE CONTENTS AND HARDWARE
(Figure 3)**

Item	Description	Quantity
J	Extension Knob Assembly	2
K	Work Support Connector	2
L	Work Support Connector Knob	2
M	Wheel Support Assembly, Right	1
N	Wheel Support Assembly, Left	1
P	Work Support Connector Screw (M6x35)	2
Q	Work Support Connector/ Saw-Mounting Washer (6.4)	10

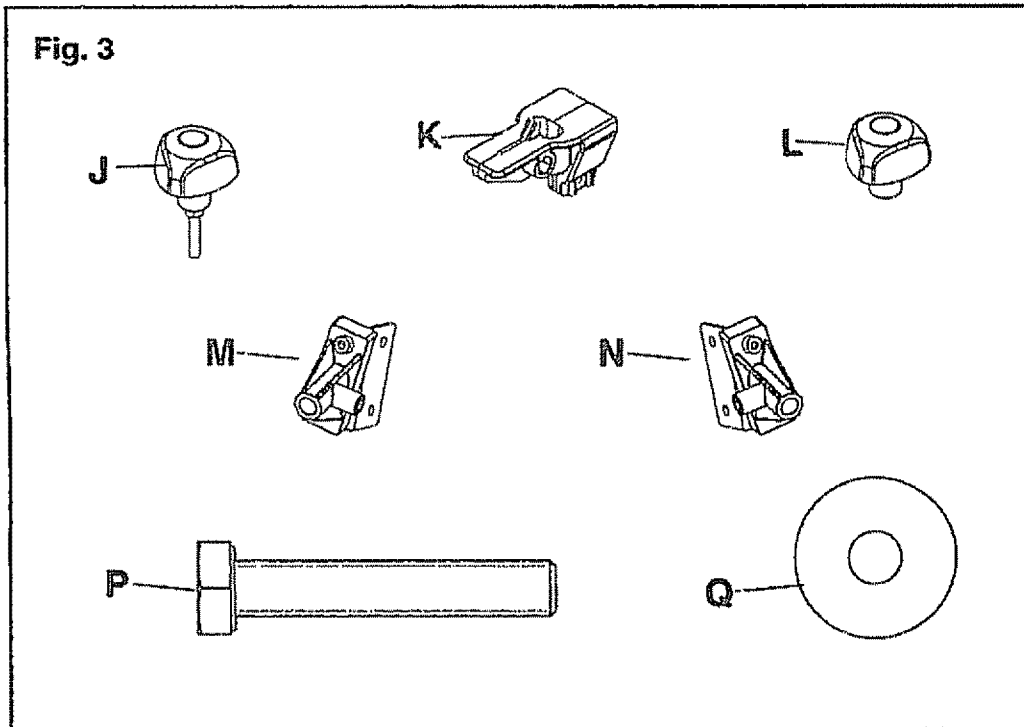

CARTON CONTENTS (cont.)

PACKAGE CONTENTS AND HARDWARE (Figure 4)

Item	Description	Quantity
R	Edge Guide-Mounting Pan-Head Screw (M8x16) (preinstalled)	4
S	Edge Guide-Mounting Square Nut (M8) (preinstalled)	4
T	Wheel Support-Mounting Pan-Head Screw (M6x12)	4
U	Handle-Mounting Pan-Head Screw (M8x20)	2
V	Rubber Foot	4
W	Rubber Foot-Mounting Screw (M4x16)	4
X	Saw-Mounting Screw (M6x70)	4
Y	Saw-Mounting, Wheel Support Nut (M6)	8

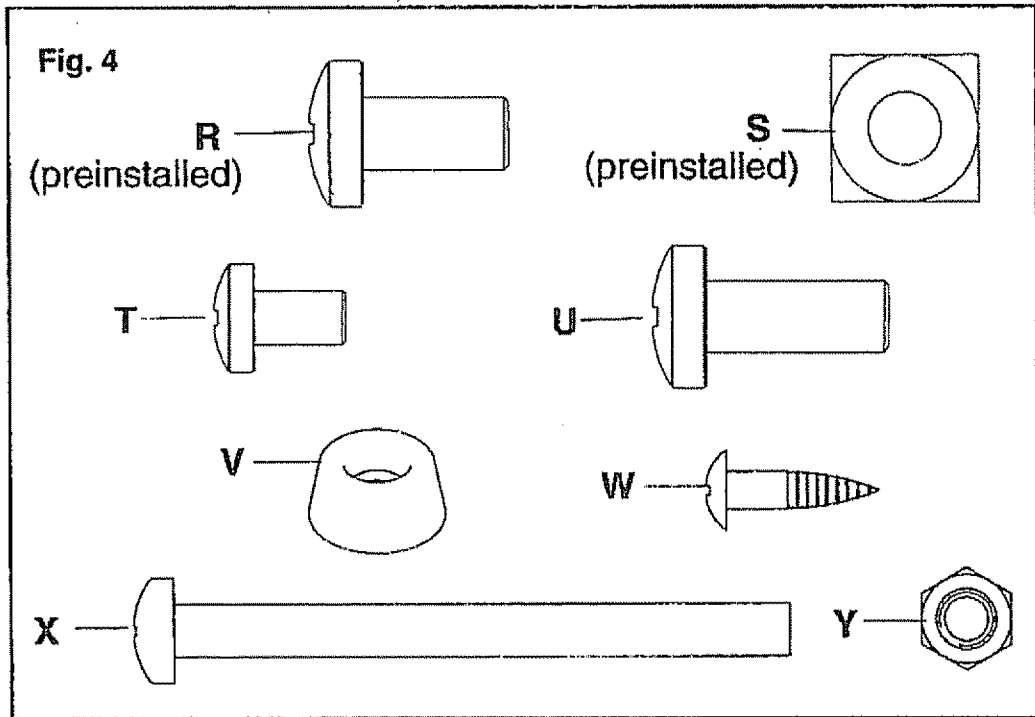

ASSEMBLY

⚠ WARNING FAILURE TO HEED ALL SAFETY AND OPERATING INSTRUCTIONS AND WARNINGS REGARDING USE OF THIS PRODUCT CAN RESULT IN SERIOUS BODILY INJURY.

Tools Needed

- #2 Phillips Screwdriver
- Two Adjustable Wrenches

PREPARE STAND FOR ASSEMBLY (Figure 5)

Place the frame assembly (A) upside down on a flat surface as shown in Figure. 5.

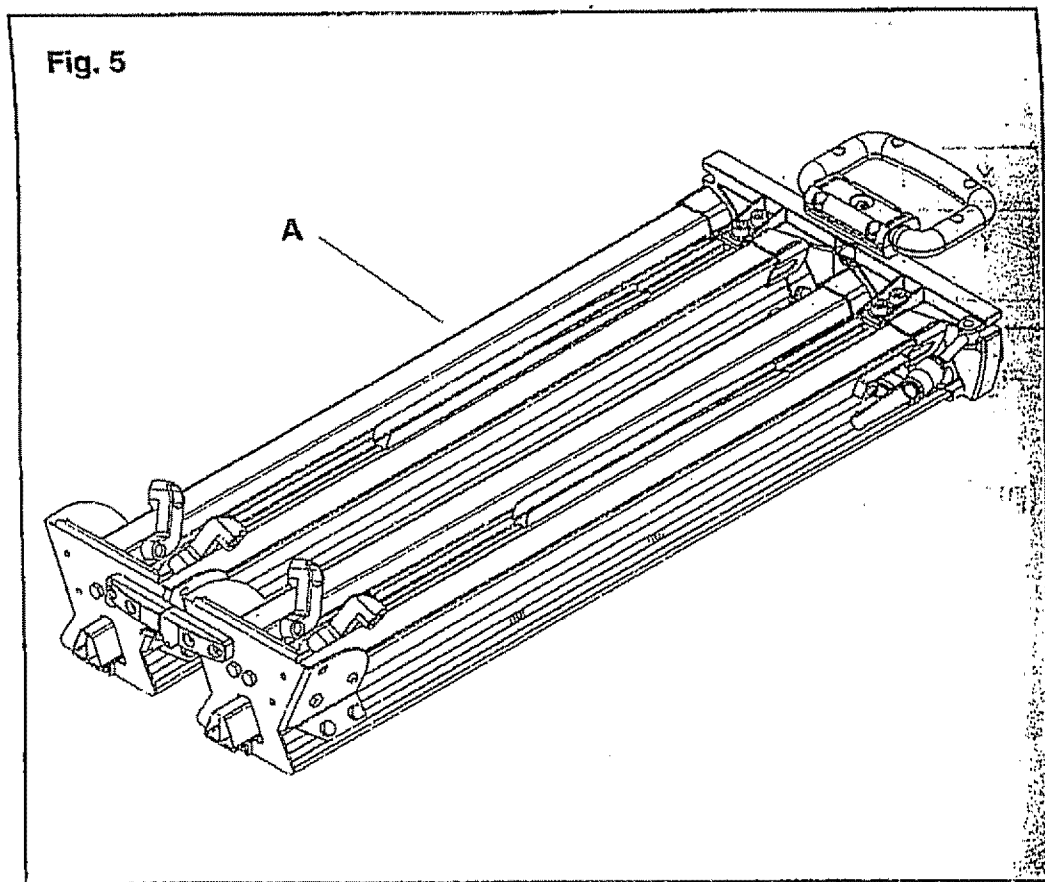

ASSEMBLY (cont.)

INSTALL WHEEL BRACKET ASSEMBLIES
Figures 6 - 8)

Fig. 6

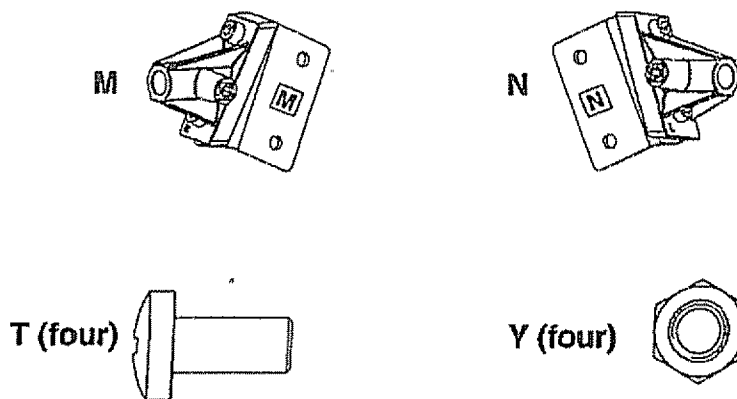

Correct locations for wheel support assemblies are identified by the appropriate sticker on the face of the metal bracket. With the frame upside down, from the end view in Figure 7, assembly M will be mounted on the left side. Ensure assembly M matches "M" sticker on frame.

Assembly N will be mounted on the right side. Ensure assembly N matches "N" sticker on frame. See Figure 7.

Fig. 7

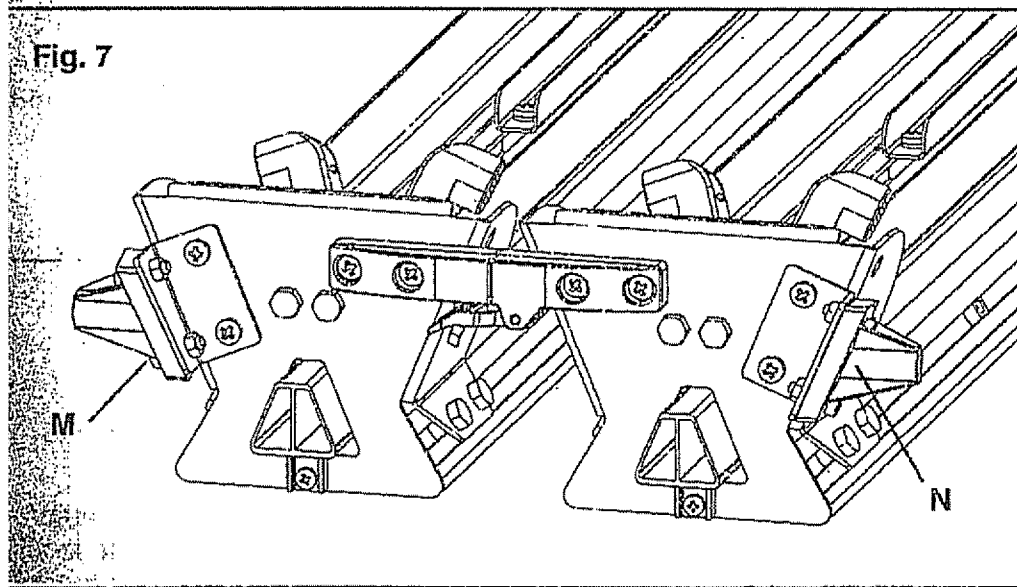

ASSEMBLY (cont.)

INSTALL WHEEL BRACKET ASSEMBLIES, cont.

Mount wheel support assemblies (M) and (N) to ends of connector brackets on frame using pan-head screws (T) and nuts (Y) as shown. See Figure 8.

Be sure wheel support assemblies are positioned correctly on connector brackets by matching stickers "M" and "N."

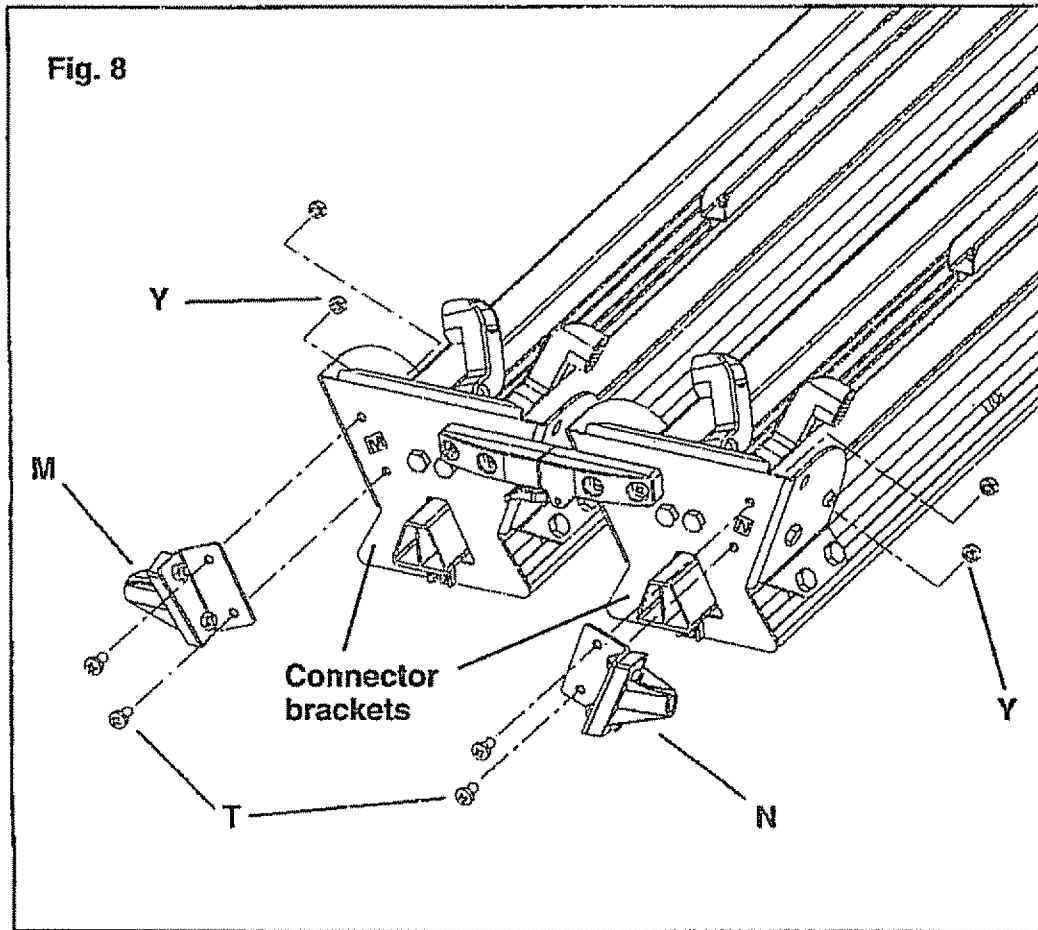

ASSEMBLY (cont.)

UNFOLD AND LATCH FRAME (Figures 9 and 10)

Unfold frame by releasing snap lock and rotating frame sections apart until aligned. See Fig. 9.

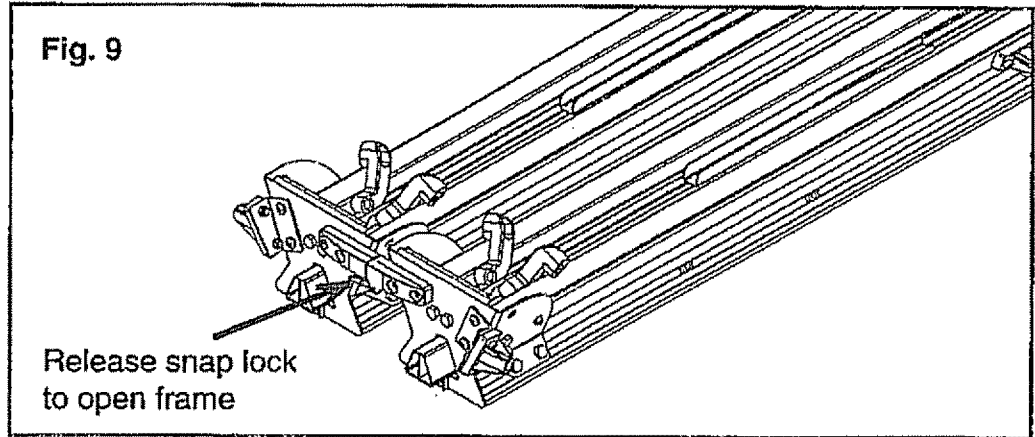

Latch frame together using adjustable handle. The handle may be repositioned to gain clearance while turning: lift the handle to disengage from gear teeth, rotate to desired position, release the handle to re-engage gear teeth and continue to tighten. See Figure 10.

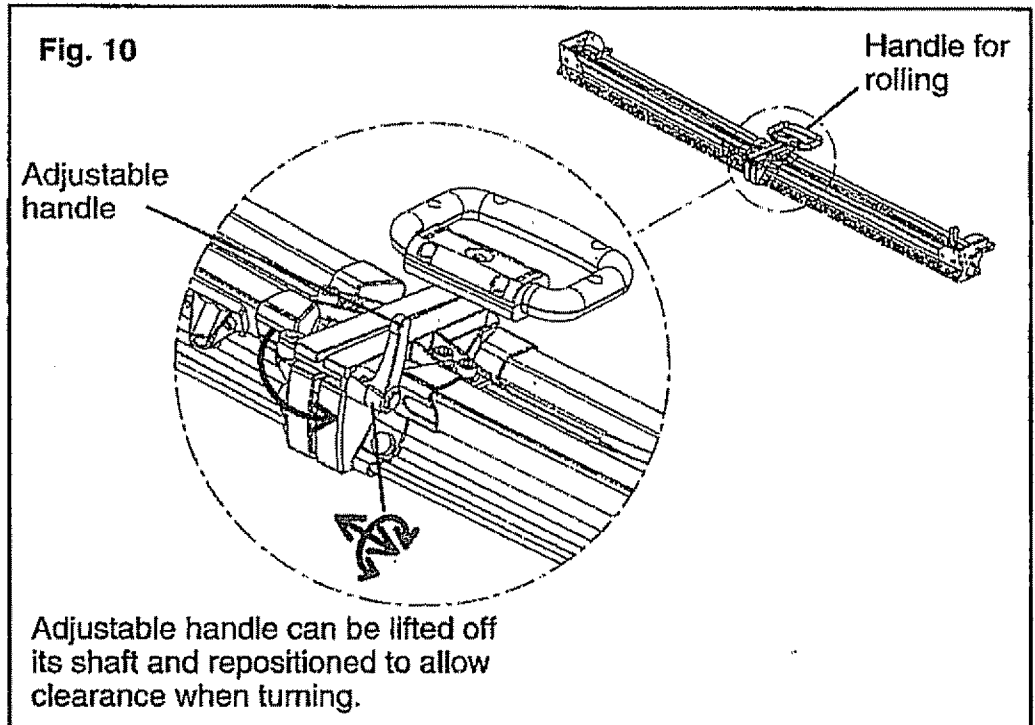

ASSEMBLY (cont.)

UNFOLD LEGS (Figures 11 and 12)

Unfold legs by disengaging locking pins and rotating the legs until the locking pins snap into the open position. If depressing the locking pins is difficult, move the leg slightly to eliminate pressure on the pin. See Figures 11 and 12.

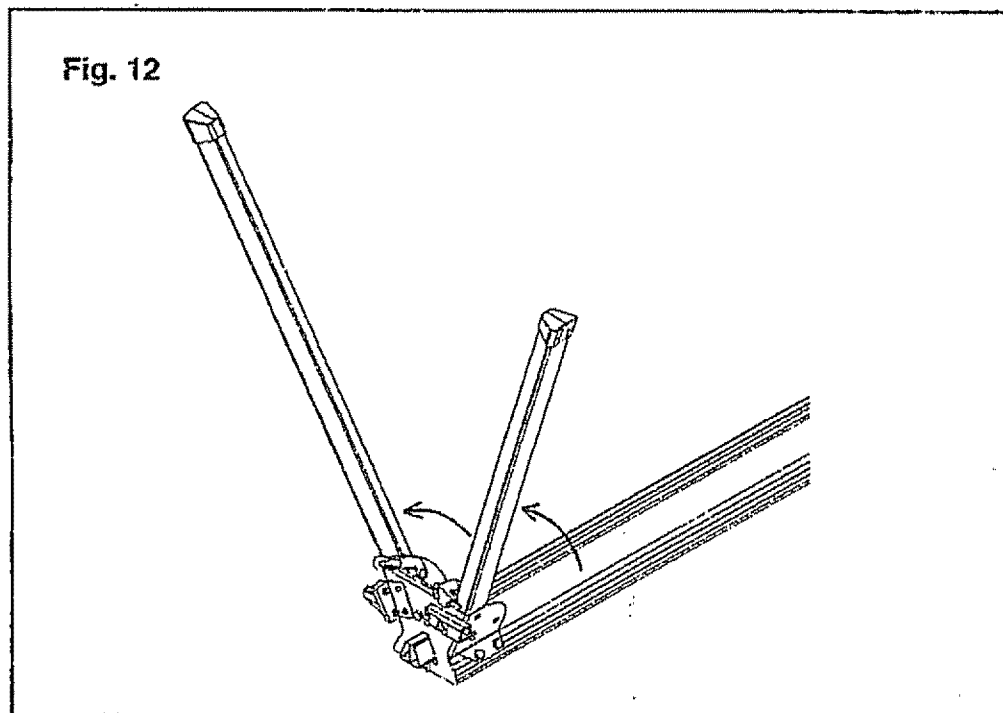
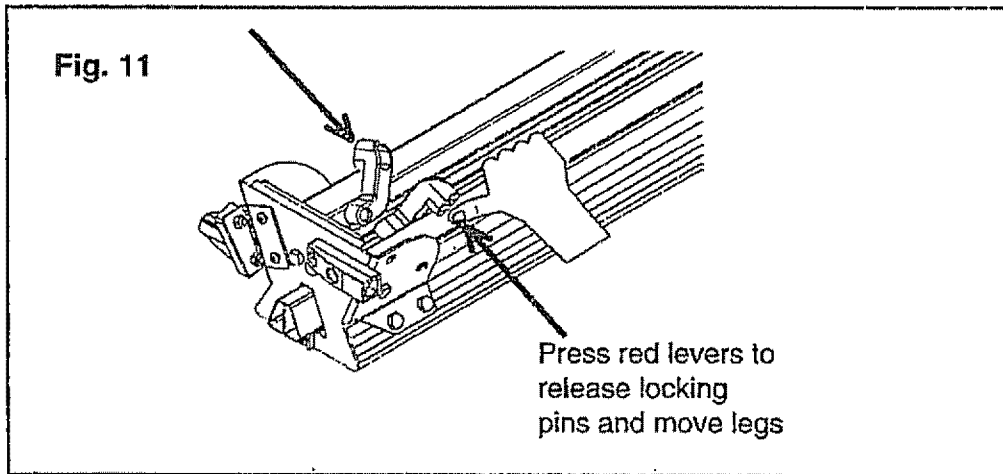

ASSEMBLY (cont.)

**INSTALL EXTENSION KNOBS
(Figures 13 and 14)**

Locate extension spacer nuts and align with holes in frame as shown. Thread extension knob assemblies (J) through the nuts to secure extensions. See Figure 14.

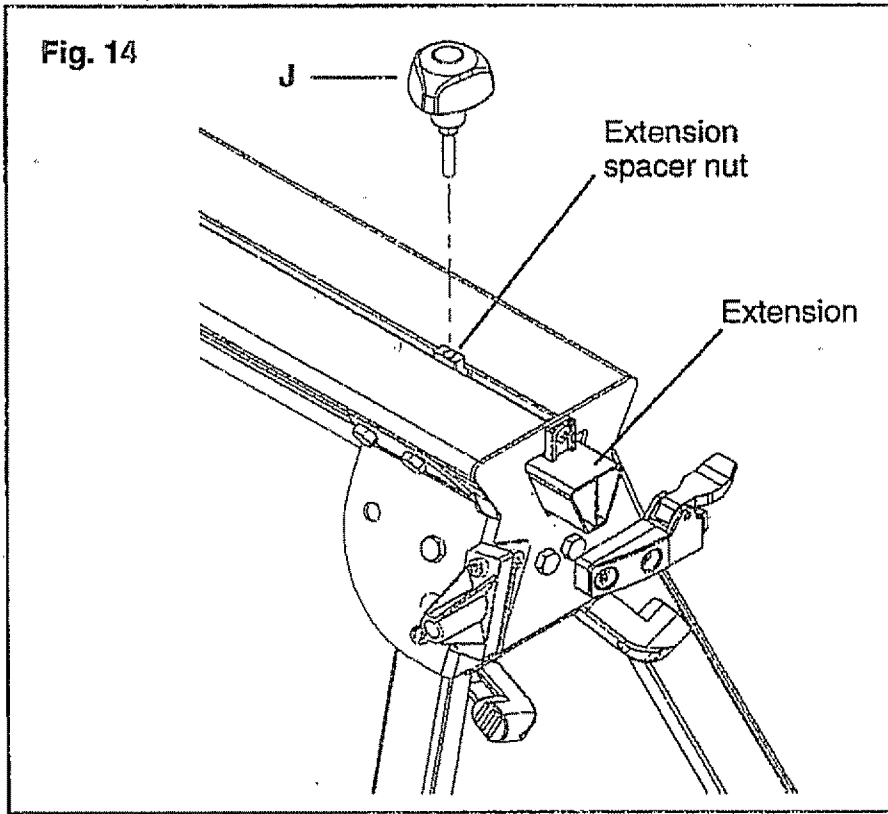
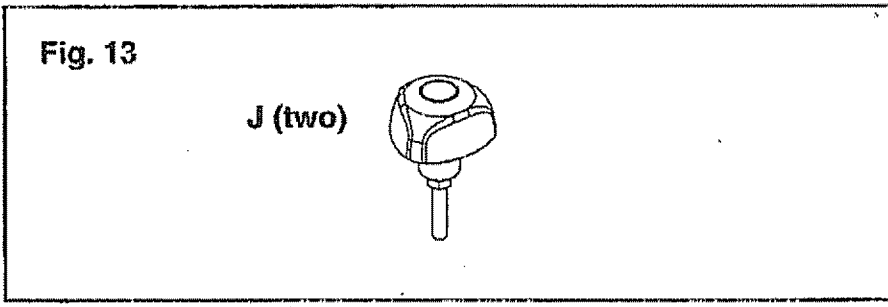

ASSEMBLY (cont.)

INSTALL SUPPORTS (Figures 15 and 16)

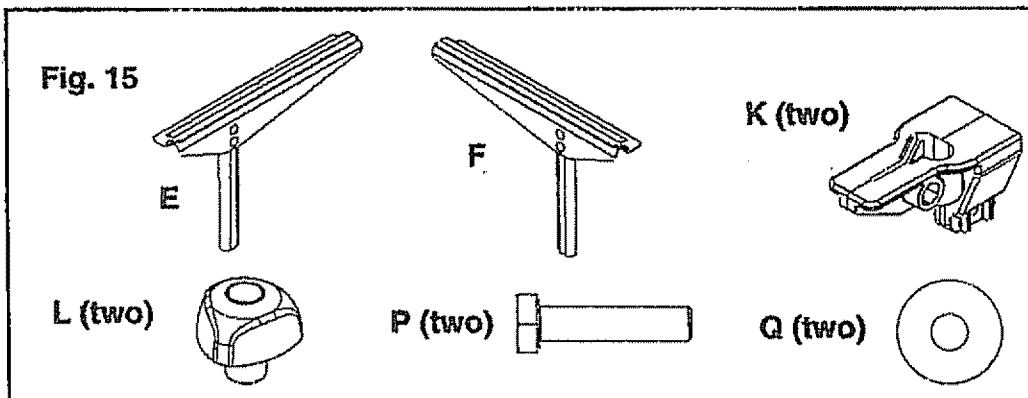

Position a support connector (K) on end of each extension and tighten Phillips-head screw to secure. Add knob (L), screw (P), and washer (Q) as shown. For both sides, the knob should face the front of the stand. See Figure 16.

Add work supports (E) and (F) on each end of stand. The long side of each support should point toward front of stand. Tighten knob (M) to secure support.

NOTE: When inserting the work support assemblies (E and F) into the support connector (K), you may encounter a slight interference. The interference can be overcome by first loosening the knob (L) and pushing the work support assembly down from the top. The second step is to push the oval support tube up from the bottom. Repeat these steps a few times to provide additional clearance and allow for smooth adjustment of the support bracket.

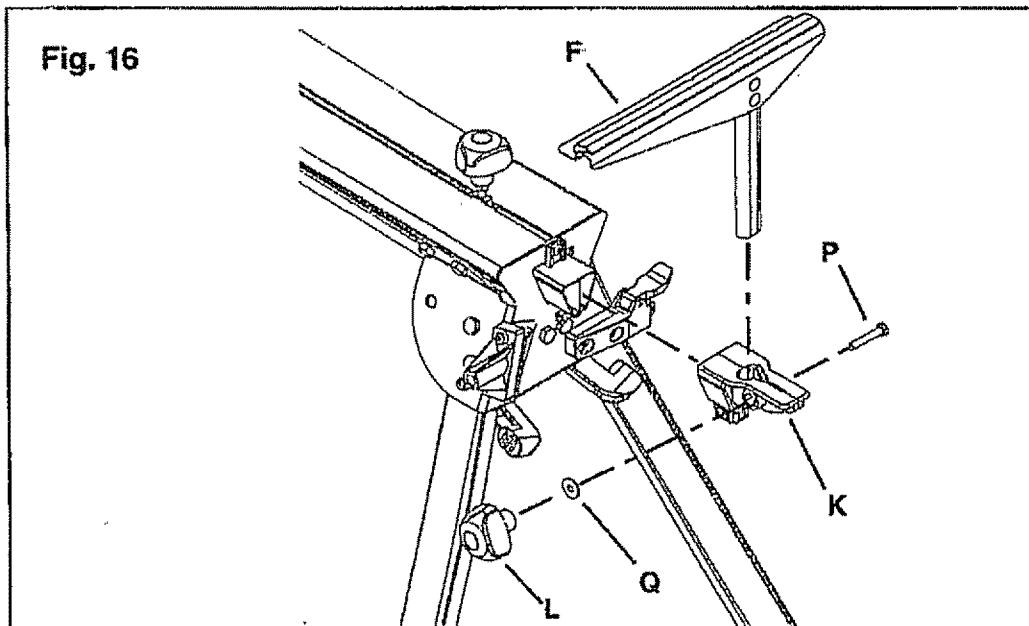

ASSEMBLY (cont.)

**INSTALL EDGE GUIDES
(Figures 17 - 20)**

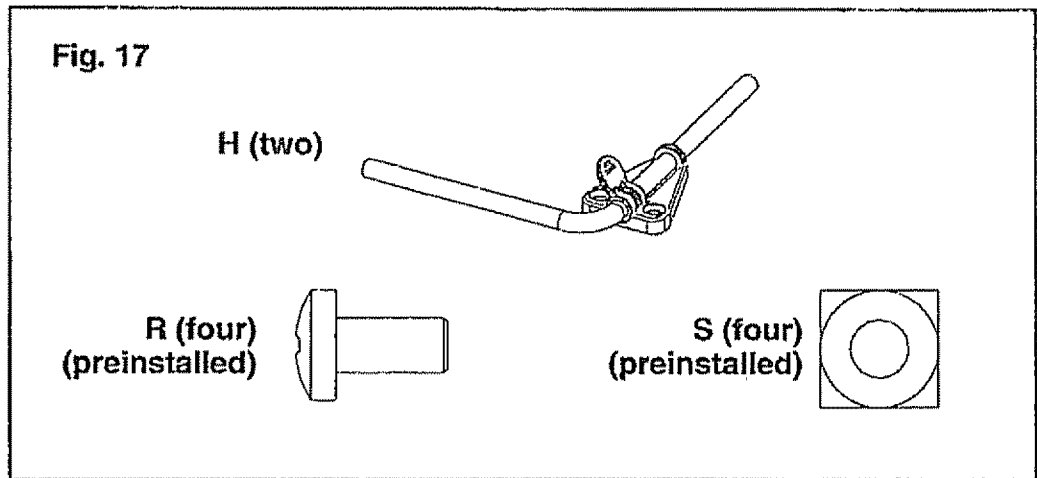

Two sets of edge-guide mounting screws (R) and nuts (S) are preinstalled on each end of the stand. Remove the screws and retain for mounting the edge guides. See Figure 18.

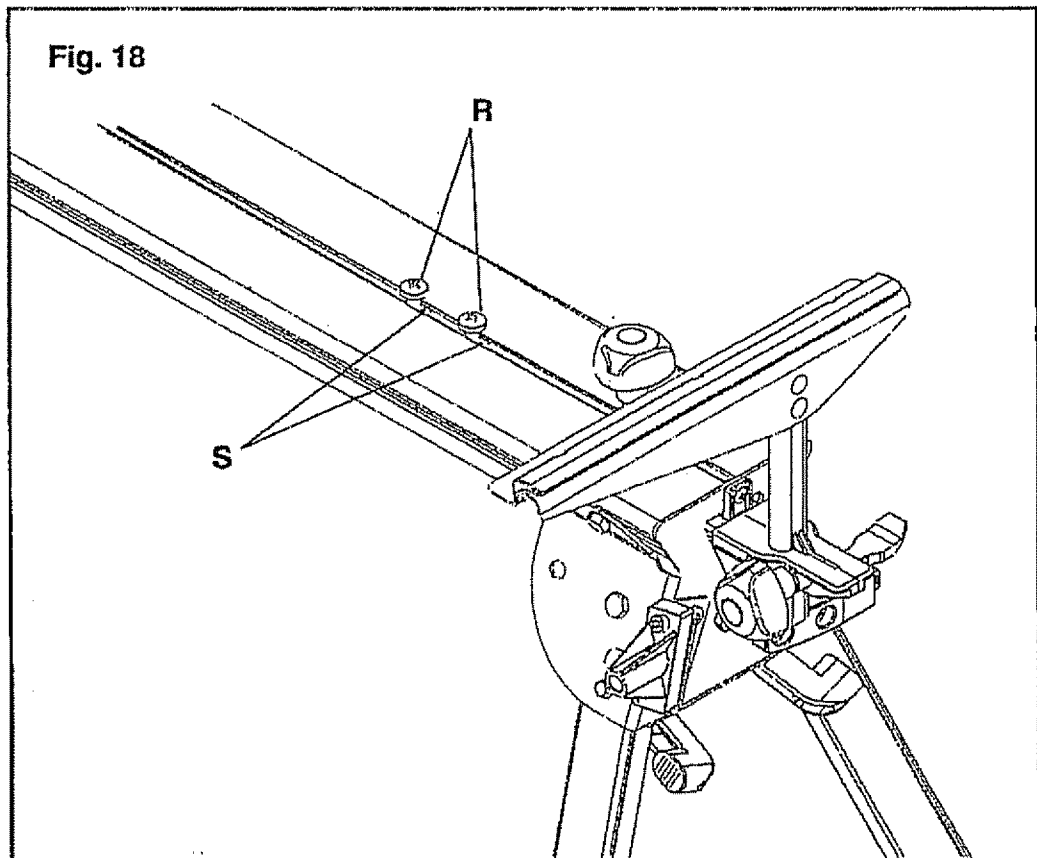

ASSEMBLY (cont.)

INSTALL EDGE GUIDES, cont.

Position edge guides (H) over nuts (S) and secure using screws (R). See Figure 19.

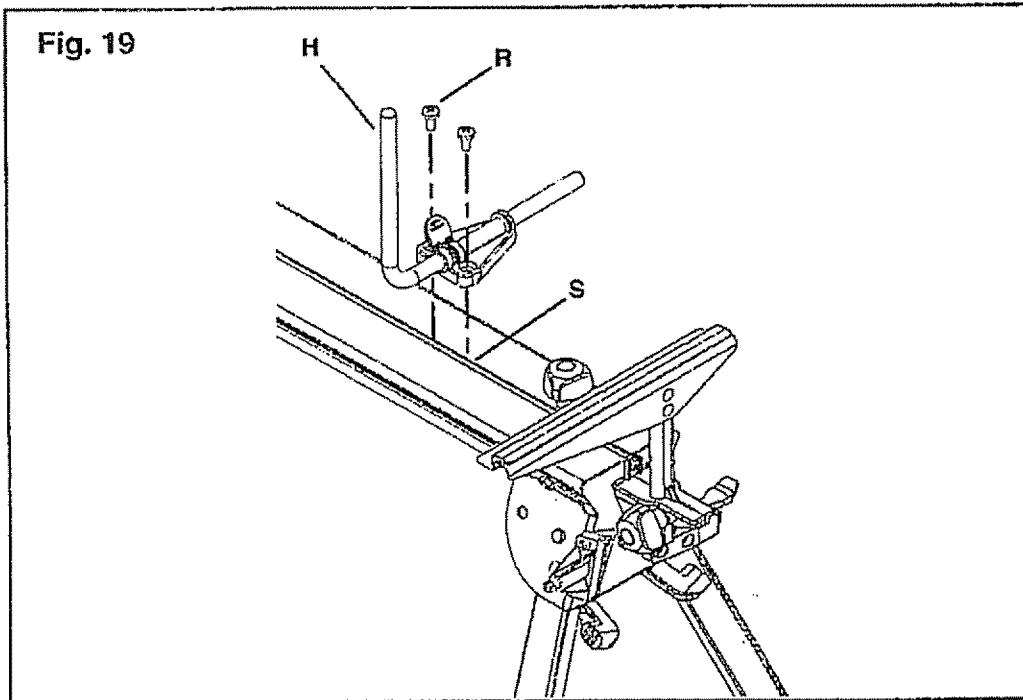

Edge guide may be positioned as desired. Rotate edge guide lever to loosen and tighten edge guide support. See Figure 20.

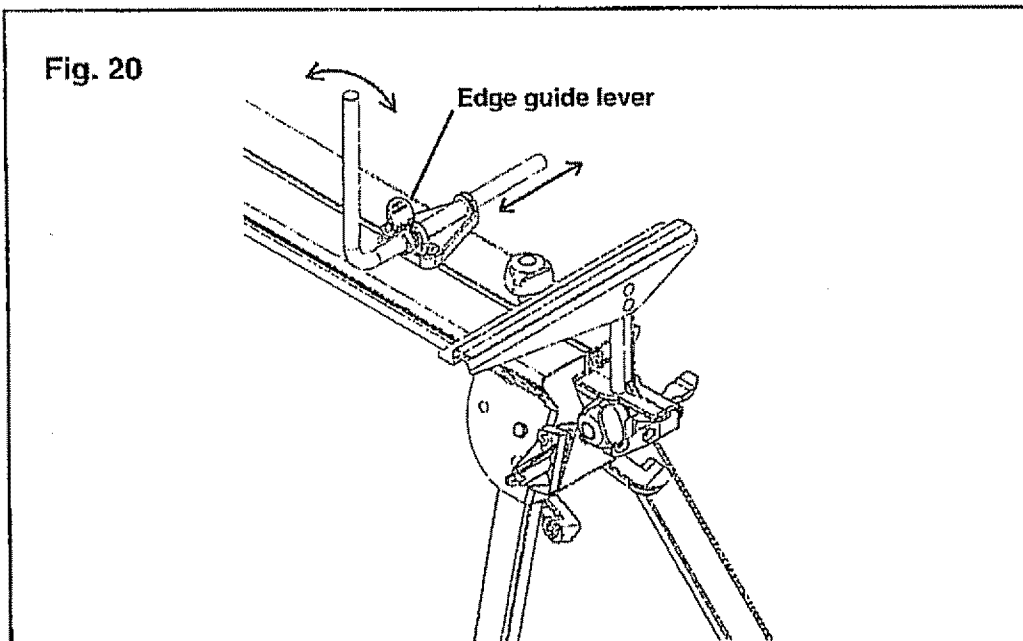

ASSEMBLY (cont.)

**INSTALL CLAMPING SYSTEM
(Figures 21 - 23)**

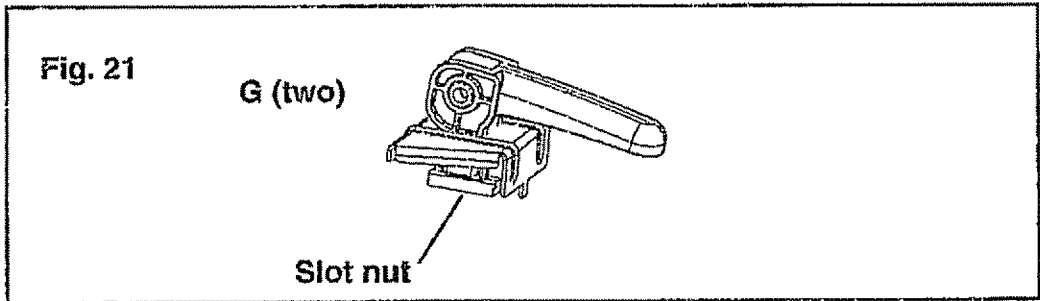

Align slot nut of clamp (G) in center frame slot. Rotate clamp so tab fits into slot. Repeat for both sides of stand. See Figure 20.

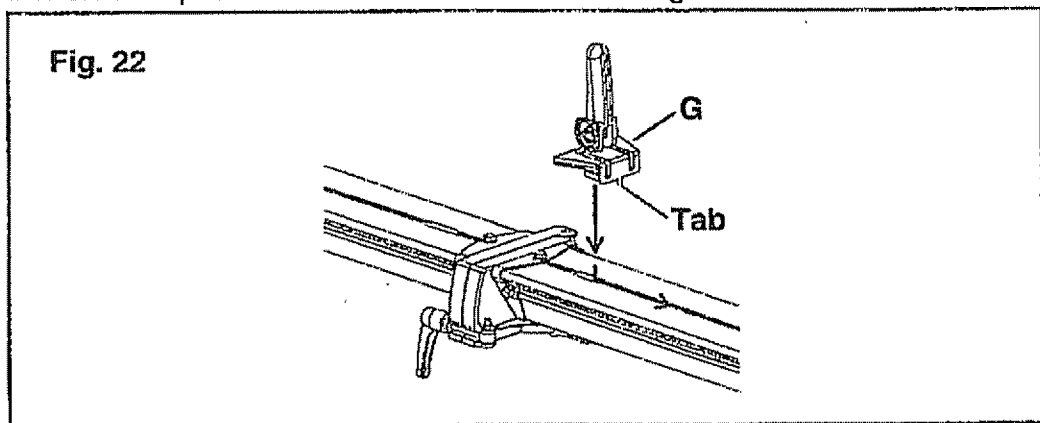

Slide clamps toward ends of stand. Tighten clamps by lowering handles. See Figure 21.

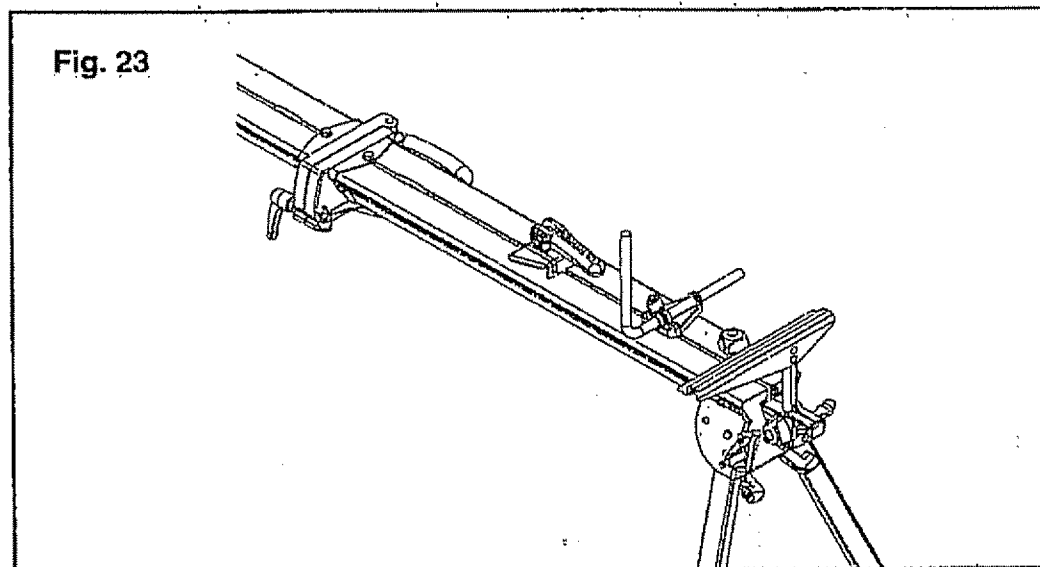

ASSEMBLY (cont.)

**INSTALL CARRYING HANDLE
(Figures 24 - 26)**

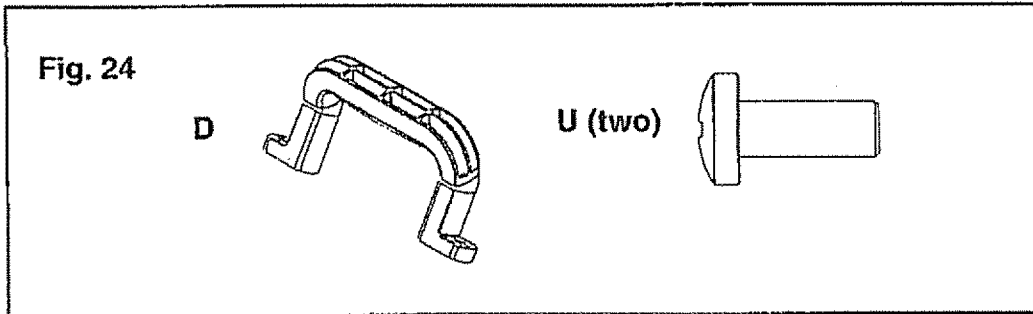

Locate the two nuts in the front slot on right side of stand, as shown in Figure 25. For best balance while carrying, align nuts with arrows marked on stand.

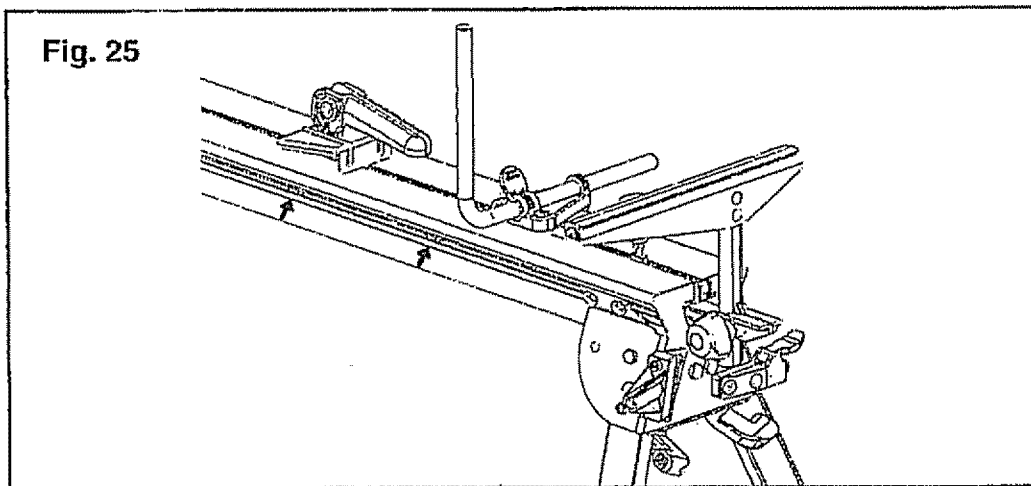

Install carrying handle (**D**) using screws (**U**). See Figure 26.

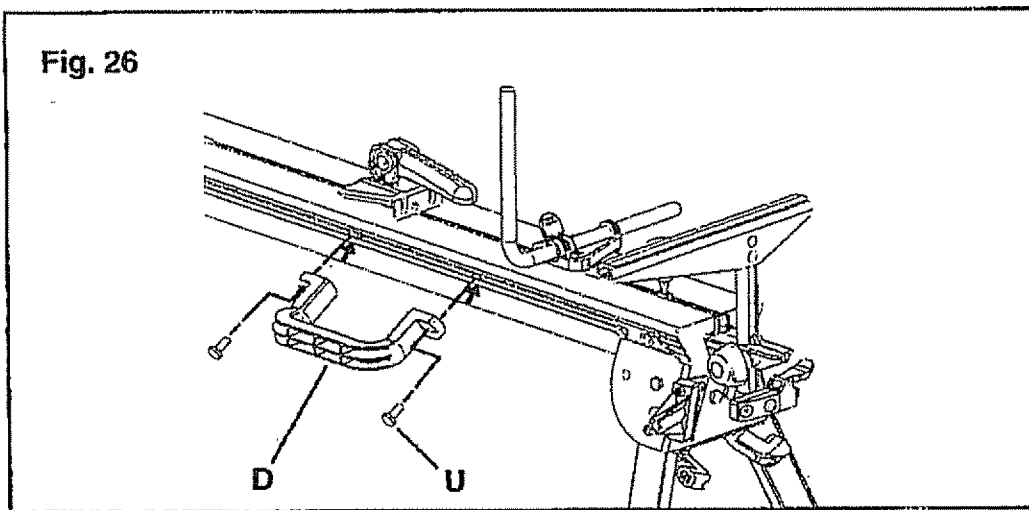

ASSEMBLY (cont.)

**INSTALL WHEELS
(Figures 27 - 30)**

Install wheel assemblies (B) by pressing axles into wheel brackets. See Figure 27.

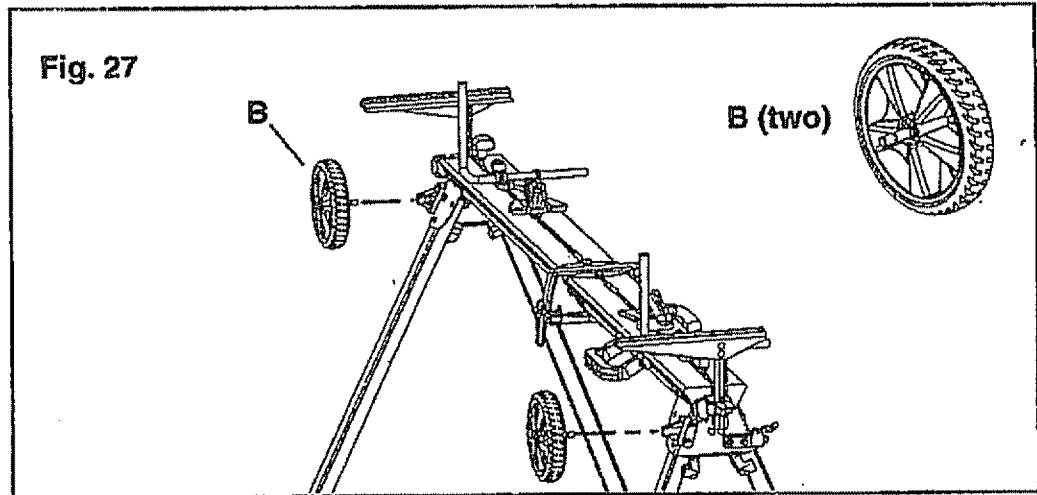

Wheels may be installed in either of two positions. During use with power tools, wheels should be in the upper position. See Figure 28.

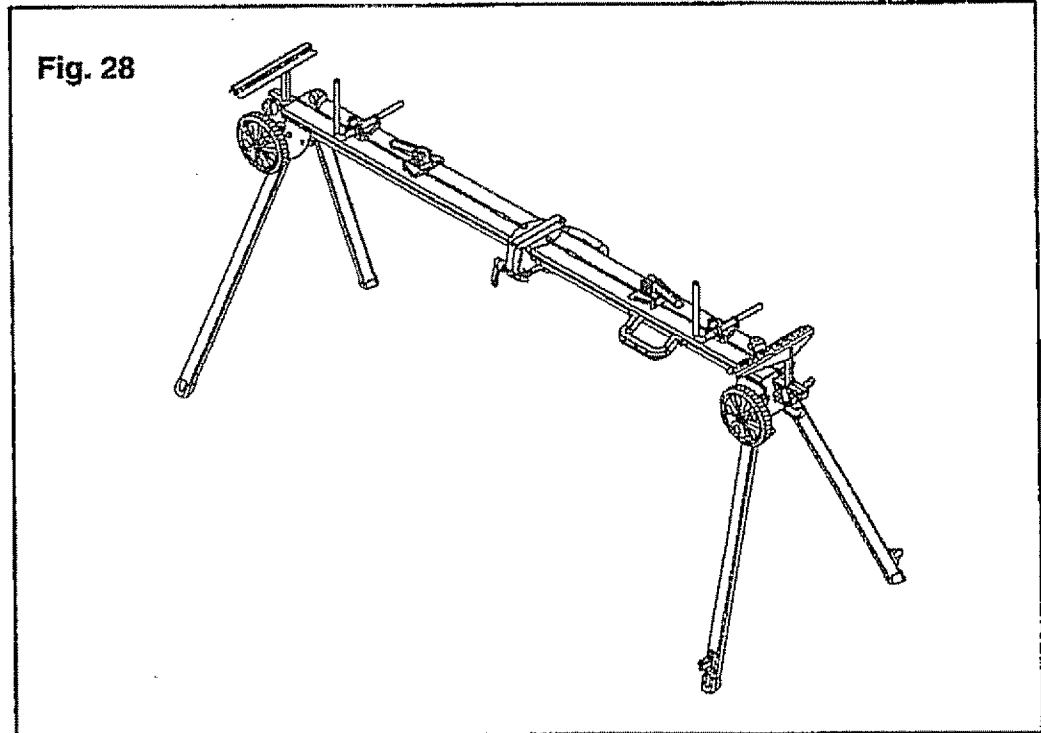

ASSEMBLY (cont.)

INSTALL WHEELS, cont.

For transporting short distances while stand is set up, wheels may be placed in the lower position. See Figure 29.

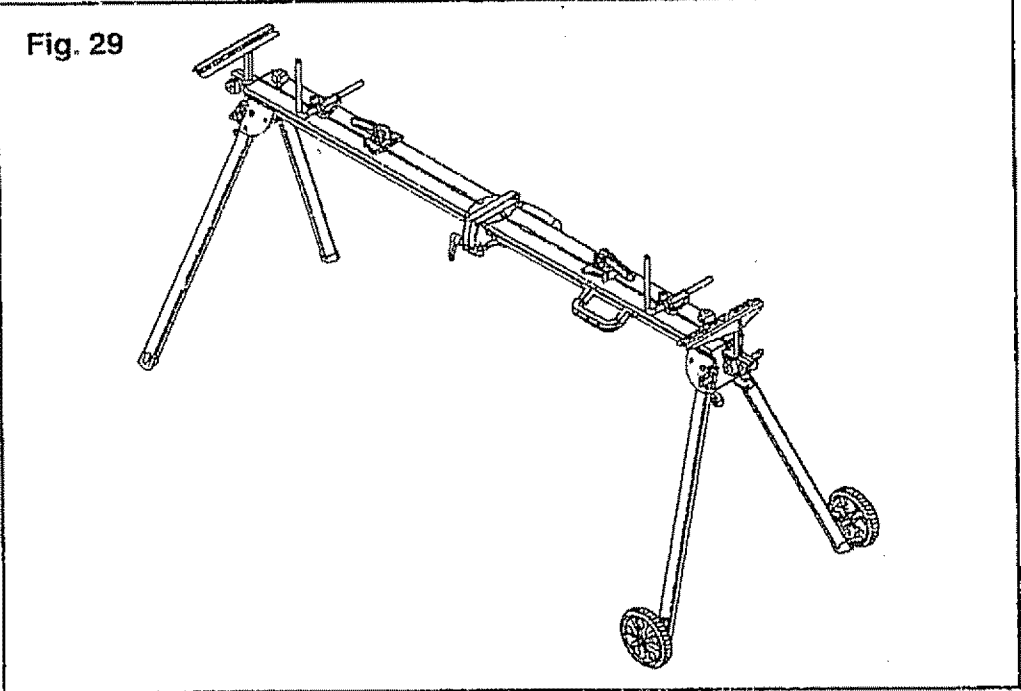

Before collapsing for storage and transport, wheels should be placed in upper position. Also see storage instructions. See Figures 30 and 44.

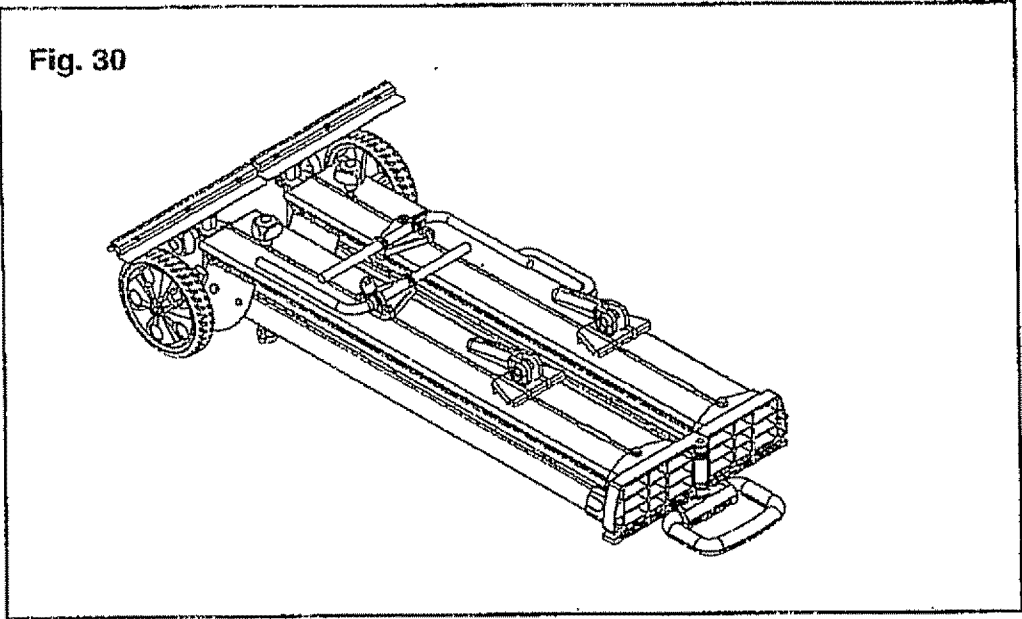

ASSEMBLY (cont.)

**ADD MOUNTING BOARDS
(Figures 31 and 32)**

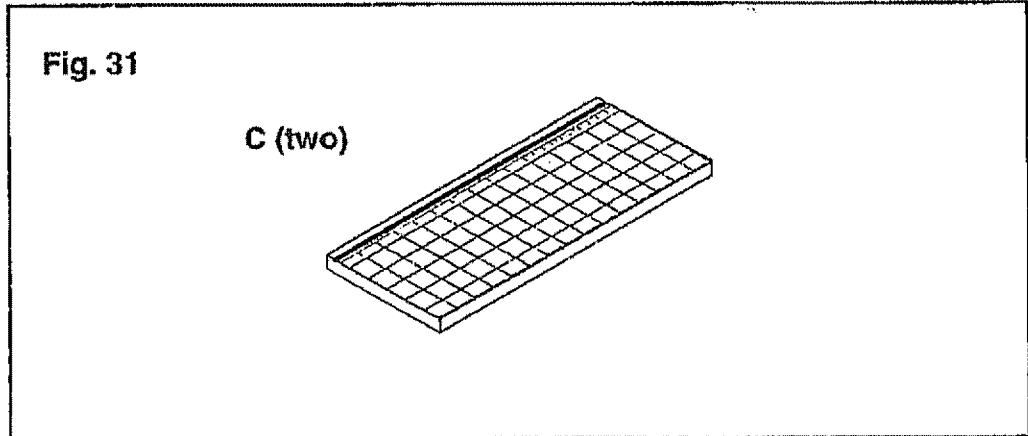

Place two mounting boards (C) on stand, slots on top and toward the outside of stand. See Figure 32.

Place clamps into slots in boards. Pivot clamp handles down to tighten against boards. See Figure 32. Clamping pressure is preadjusted at the factory. If necessary, pressure can be adjusted by tightening screw that secures clamping lever. See inset.

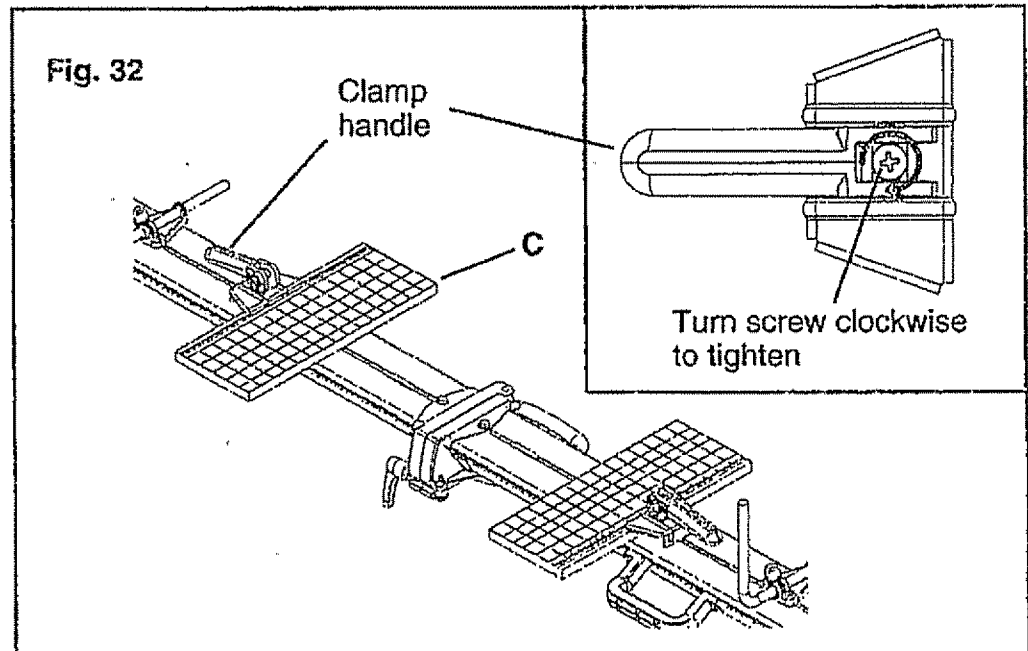

ASSEMBLY (cont.)

MOUNT THE MITER SAW (Figures 33 - 38)

MOUNTING THE MITER SAW TO THE BOARDS

Secure boards to frame of miter saw stand as explained in "ADD MOUNTING BOARDS" on page 23. Loosen clamps slightly and position boards to be slightly wider than the base of the miter saw to be mounted. To square boards, align grid on boards with the frame of the miter saw stand.

Position miter saw on boards with fence of saw in line with center of clamps. Saw base should be approximately 1" from front edge of boards and 1/2" from slot in boards. See Figure 34.

NOTE: Position saw and boards so mounting bolts will not interfere with frame of miter saw stand.



CAUTION Be sure to position your saw and boards for maximum stability.

Using a pencil, mark saw base mounting holes on boards. Remove saw and boards from stand and drill mounting holes using a 1/4" bit. Mount saw to boards using screws (X), washers (Q), and hex nuts (Y). See Figure 35.

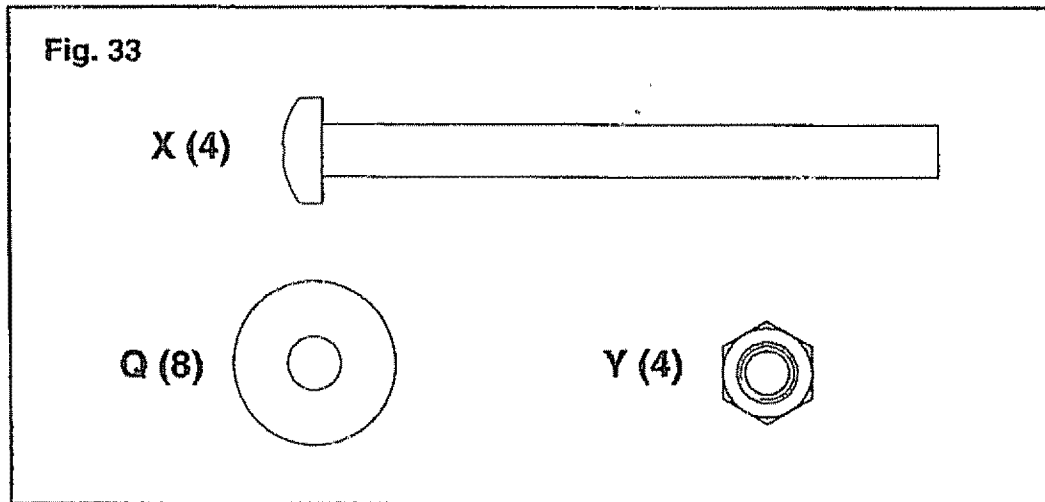

ASSEMBLY (cont.)

MOUNT THE MITER SAW, cont.

MOUNT THE MITER SAW TO THE BOARDS, cont.

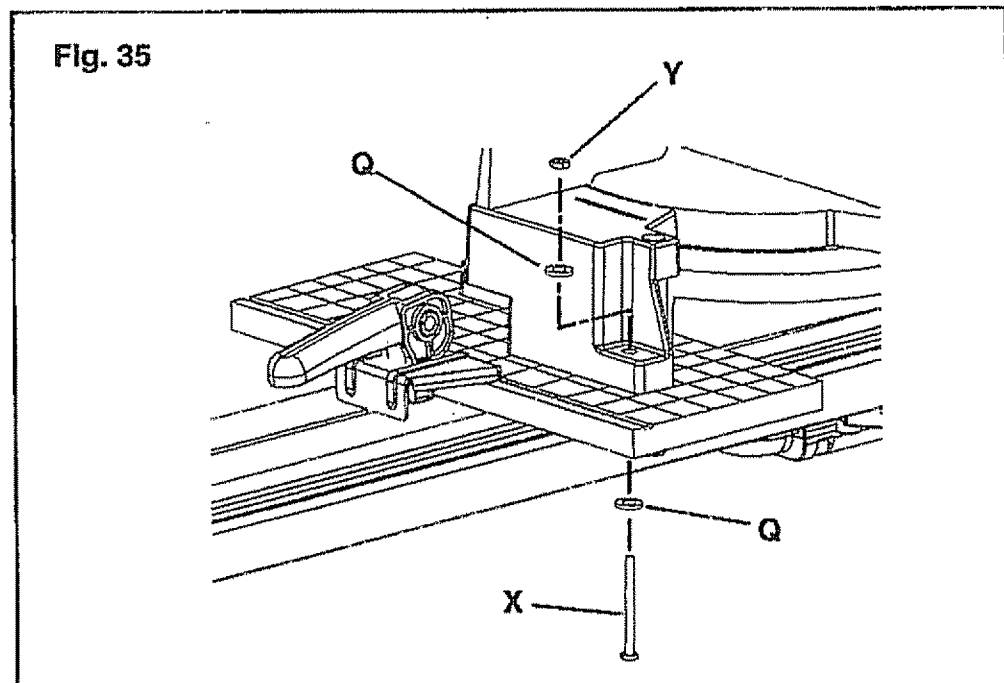
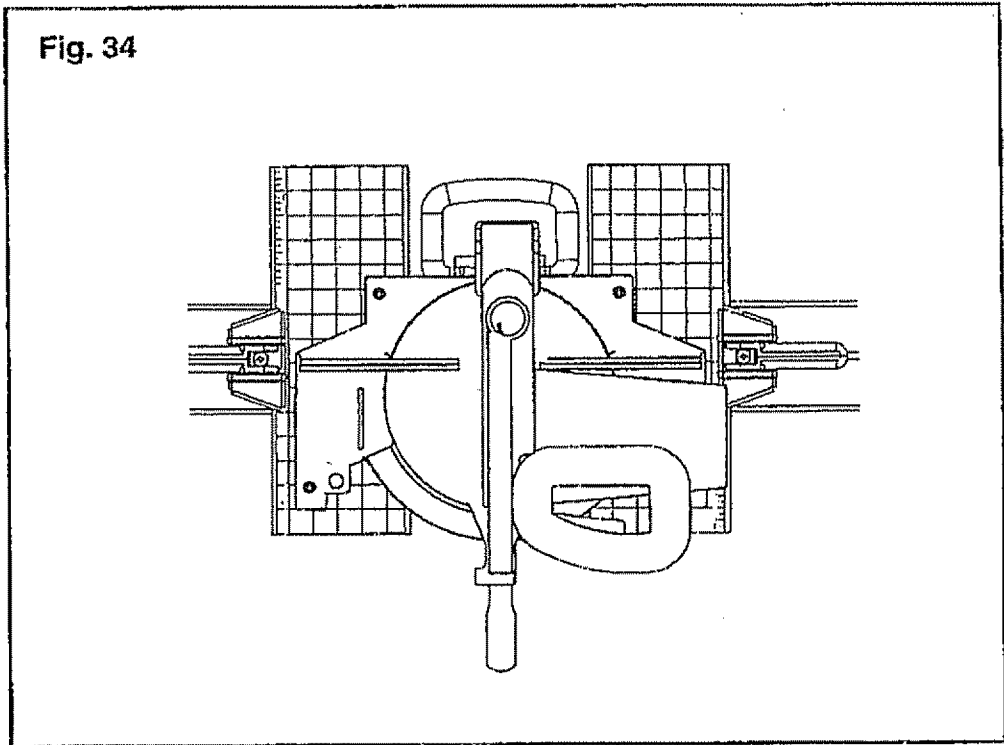

ASSEMBLY (cont.)

MOUNT THE MITER SAW, cont.

ADD RUBBER FEET TO BOTTOM OF MOUNTING BOARDS (Figures 36 and 37)

Remove boards from stand and drill two pilot holes for Screws (W) to attach rubber feet (V). The holes should be 5/64-inch diameter and 1/2-inch deep. (Four screws included.)

Attach two rubber feet to each board as shown in Figure 37. These help provide cushioning and protection when the miter saw is not mounted to the stand. Install rubber feet 1½" from edge of board as shown.



Not all miter saws mount the same. You may need to adjust location of foot pads to avoid saw-mounting screws.

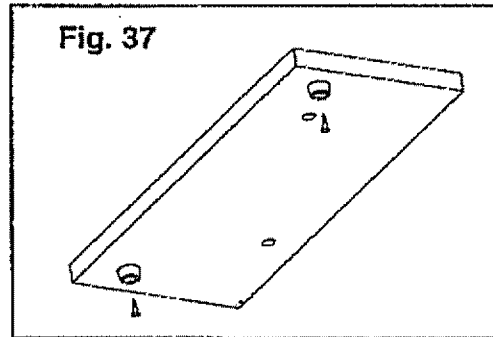
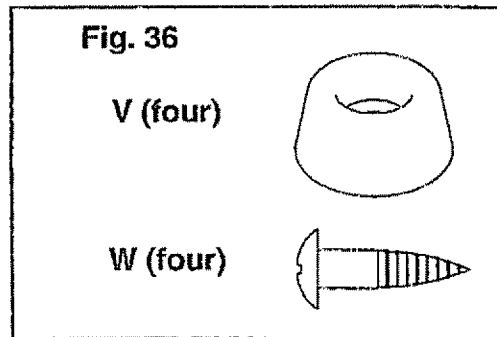

CLAMP MOUNTED SAW TO STAND AND PREPARE FOR USE (Figure 38)

Mount saw to boards and place boards on center of stand. Position for best balance. This usually places the fence of the saw in the center of the stand, front-to-back. See Figure 38.

Position clamp brackets in slots of boards and tighten securely.

With telescoping extensions pushed in, set height of supports even with table of miter saw.

Extend telescoping extensions to support workpieces and position edge guide and stop as required.

Fig. 38

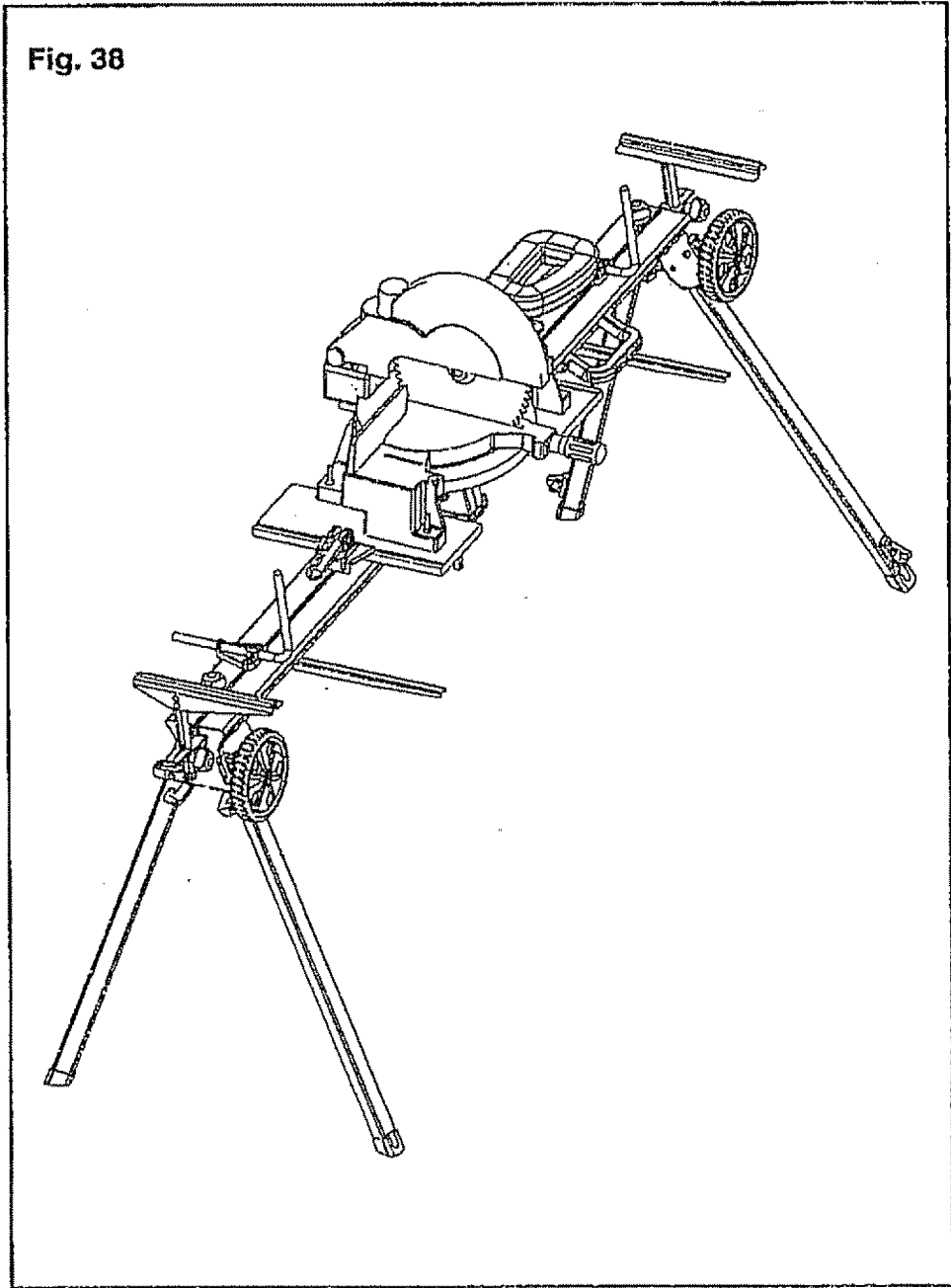

MITER SAW COMPATIBILITY

This work stand is designed for use with Craftsman and most other brands of miter and compound miter saws. The saw will mount directly to the boards provided with the stand. It will also accommodate saws with unusual mounting hole patterns. Simply follow the preceding instructions.

The following models will mount directly to the boards provided with the stand

BRAND	MODEL NUMBER	BRAND	MODEL NUMBER
Craftsman	21211	Milwaukee	6496
	21218		6490
	21222		6494
	21230	Porter-Cable	3802
	21240		3807
	21292		
	24315		
Delta	36-040	Pro-Tech	7107
	36-070		7207
	36-075		7208
	36-225		72121
	36-235		
36-240			
DeWalt	703	Rigid	MS1050
	705		MS1250
	706	Ryobi	TS1301DX
	708		
Hitachi	C10FCD	Skil-Bosch	3810
	C10FM		3912
	C15FB		3915
			3924
Makita	BLS712	Tool Shop	JIZ-ZP-305
	BLS820SFK		
	LS711DWBEK		
	LS800DWB		
	LS1013		
	LS0711Z		
	LS1212		
	LS1220		

MOUNTING OTHER TOOLS

Mounting Non-Standard Miter Saws and Other Tools To The Boards (Figures 39 and 40)

⚠ CAUTION DO NOT MOUNT A TABLE SAW ON THIS STAND. The direction of feed on a table saw is perpendicular to the axis of best stability on this stand. Aggressive feeding of sheet materials into a table saw could cause the stand to tip over.

This Miter Saw Stand may also be used with other bench top tools, such as chop saws, grinders, drill presses, sanders, joiners, scroll saws and band saws. (see Figure 39.)

Fig. 39

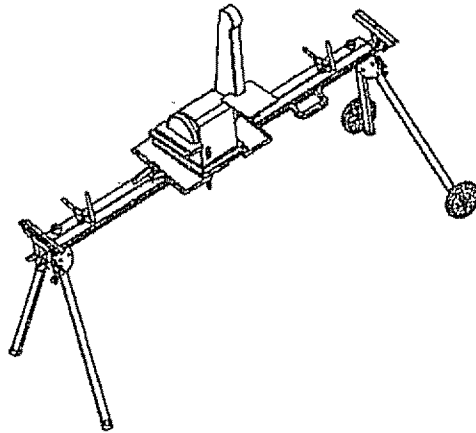

For additional tools and other miter saws with non-standard mounting holes, plywood or other boards may be used for mounting tools for use on this stand. The plywood used should be approximately 3/4 in. thick.

Cut plywood or boards to fit mounting hole pattern for tool to be used with the stand. The wood must clear center hinge area of stand and extend 1 inch in all directions beyond the bottom edge of the tool base for proper clamping to the stand. (See Figure 40.)

Fig. 40

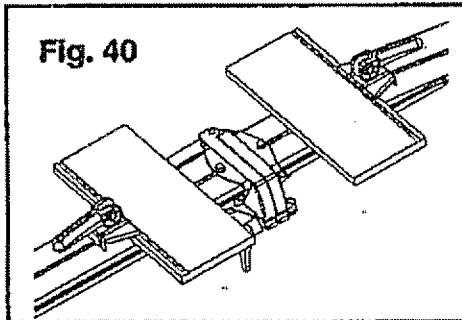

NOTE: When using mounting boards other than those included with this stand, slots matching those on the original mounting boards should be cut using a router or table saw. These slots should be 3/8" wide, 3/32" deep, and 3/8" from the edge of the boards.

Mount your tool to the plywood or boards following the directions in the Mounting Miter Saw section of this manual.

USAGE

USING THE STOCK SUPPORTS (Figure 41)

Two stock supports are located under the frame of the table. These may be pivoted out to support work pieces as desired. (See Figure 41.)

NOTE: Maximum load on stock supports not to exceed 20 pounds.

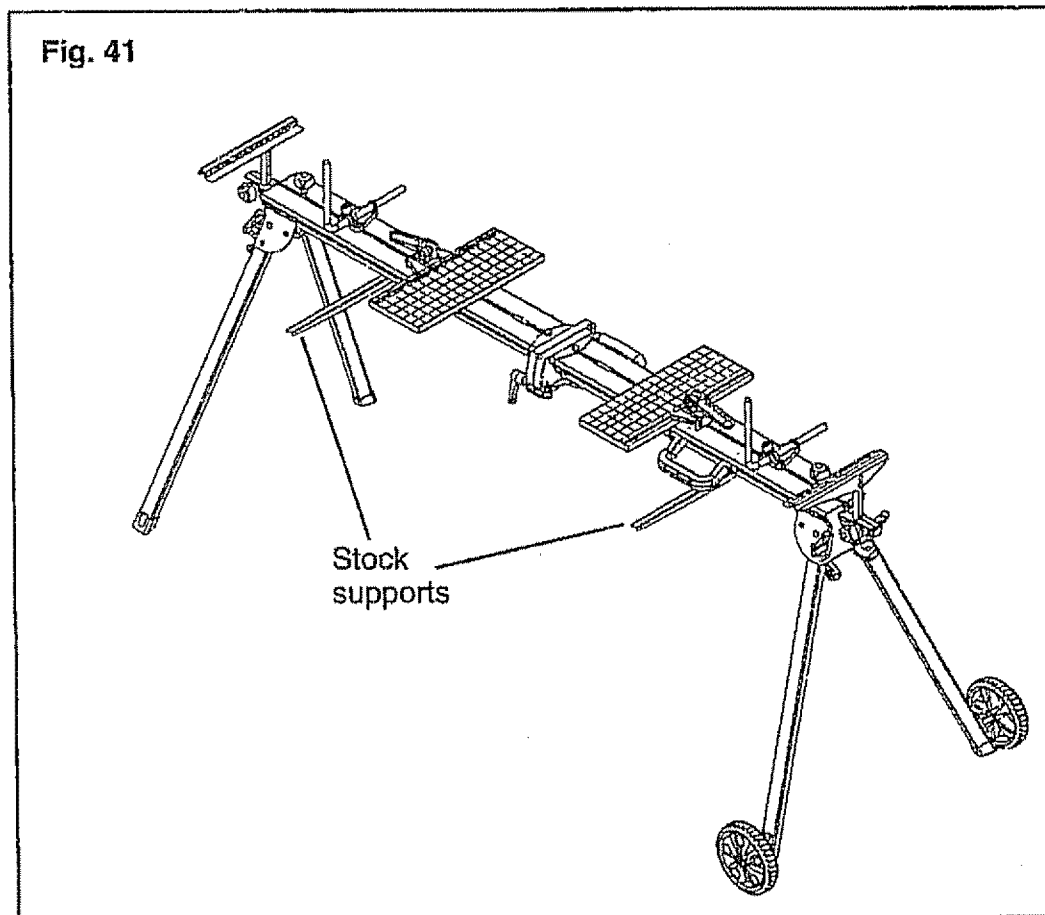

USAGE (cont.)

USING THE WORK SUPPORTS (Figure 42)

The two work supports are useful for:

- 1) Vertical support of workpieces
- 2) Positive stops for repetitive cuts

To use the work supports as vertical supports, loosen extension knobs and slide extensions in toward saw. Loosen work support knobs to set top of work supports level with table of saw. Tighten work support knobs. Position extensions and tighten knobs. See Figure 42.

To position work support for use as positive stop, slide extension out to desired measured distance from saw blade. The workpiece should rest on the metal bracket and butt up against the plastic support pad. Tighten extension knob.

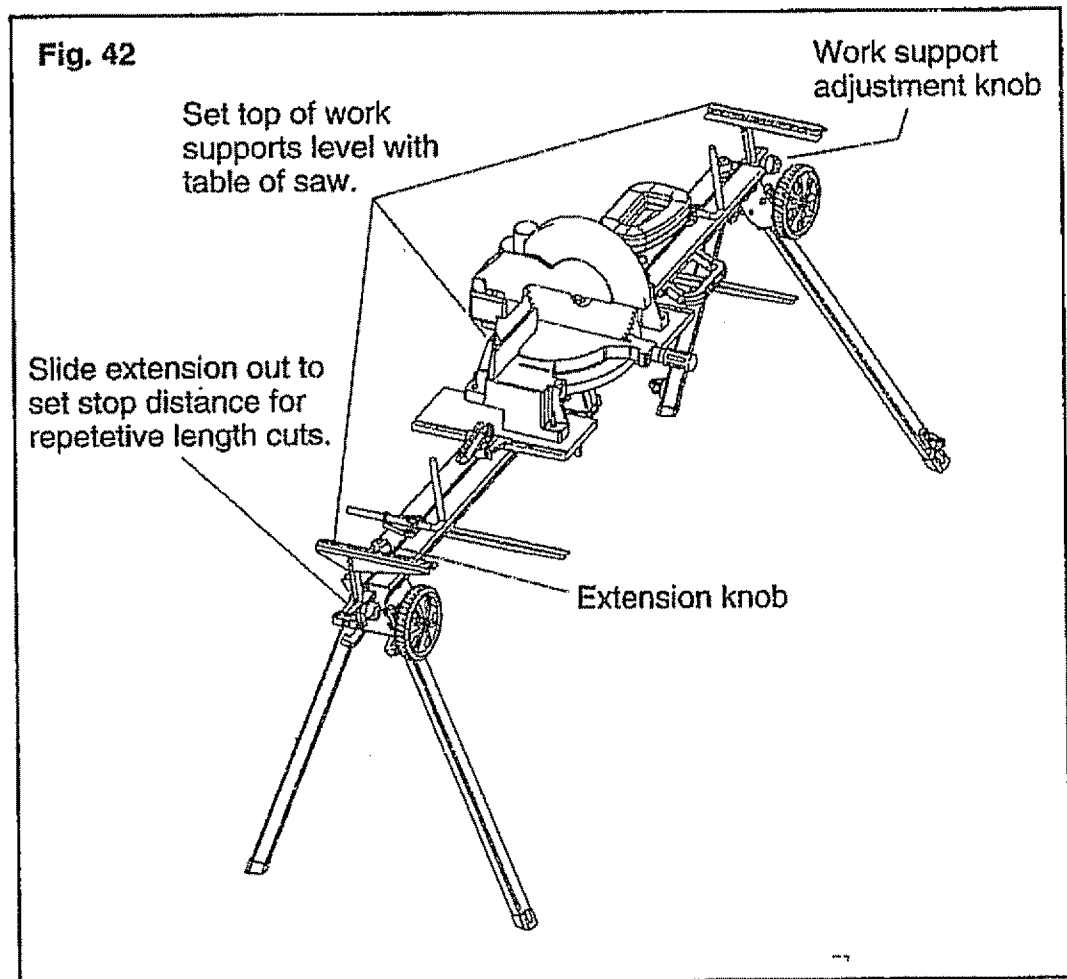

USAGE

**USING THE EDGE GUIDES
(Figure 43)**

The two edge guides are useful for maintaining orientation angle of workpieces, such as cove and crown molding.

To position edge guides for use in aligning workpieces, rotate edge guide levers to loosen clamps and slide edge guides to desired position. Retighten levers to lock edge guides. See Figure 43 inset.

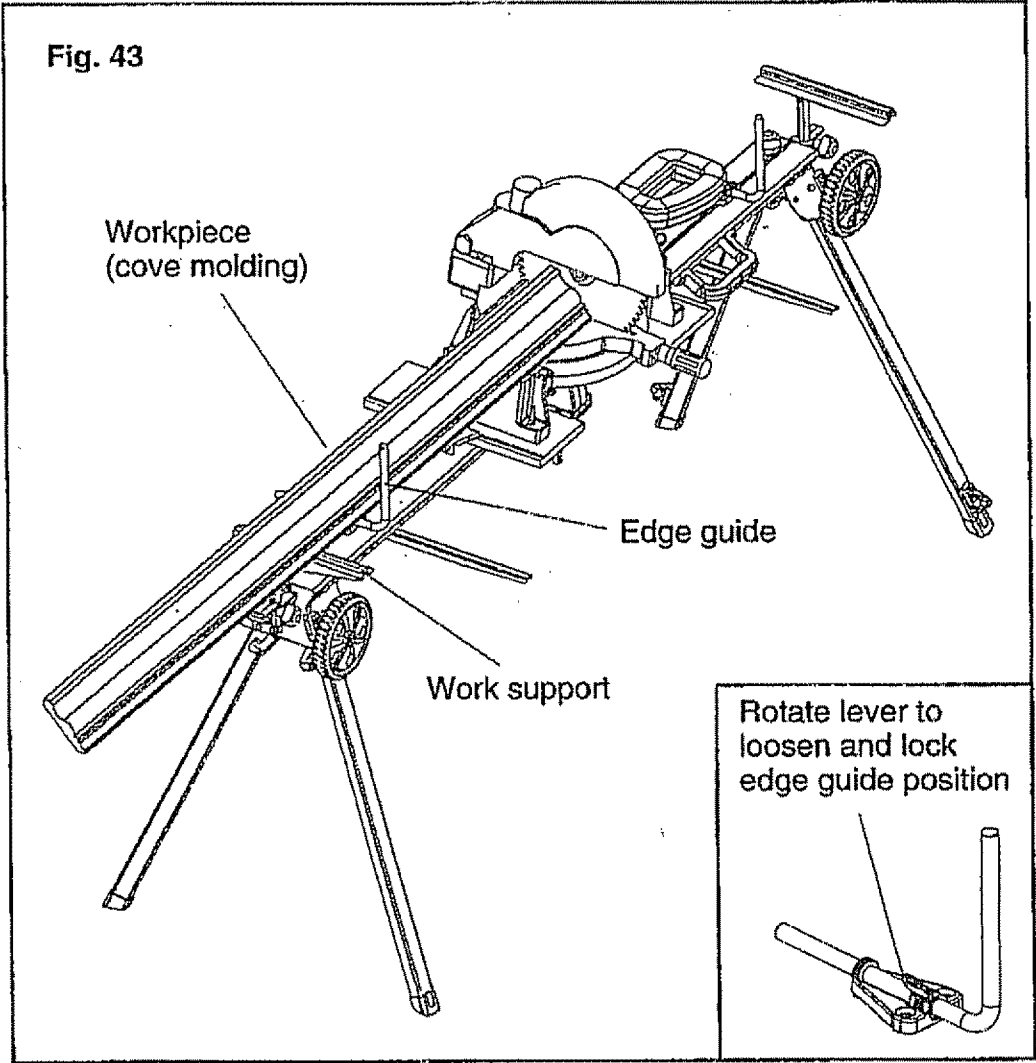

STORAGE

STORAGE INSTRUCTIONS (Figure 44)

Before moving or storing your miter saw stand:

Remove power tool and mounting boards from stand.

Move wheel assemblies to upper positions on frame.

Tighten down mounting board clamps to top of stand.

Loosen edge guides and rotate them into a lowered position.

Lower supports and retract telescoping extensions.

Fold up legs by disengaging release levers and rotating legs to folded position.

Unlock center tabletop hinge and rotate stand into collapsed position.

Latch tabletop sides together with snap lock.

Stand may be rolled easily for transport and storage. See Figure 44.

Fig. 44

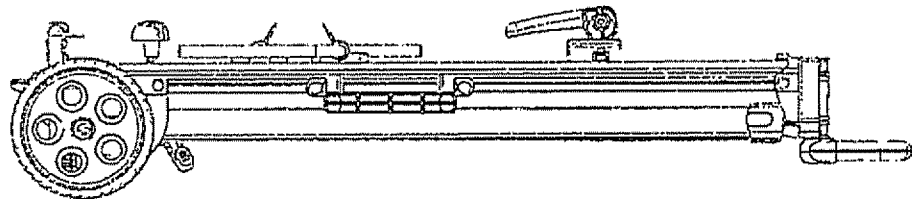

REPAIR PARTS

PARTS LIST Universal Miter Saw Stand Model No. 695.22302

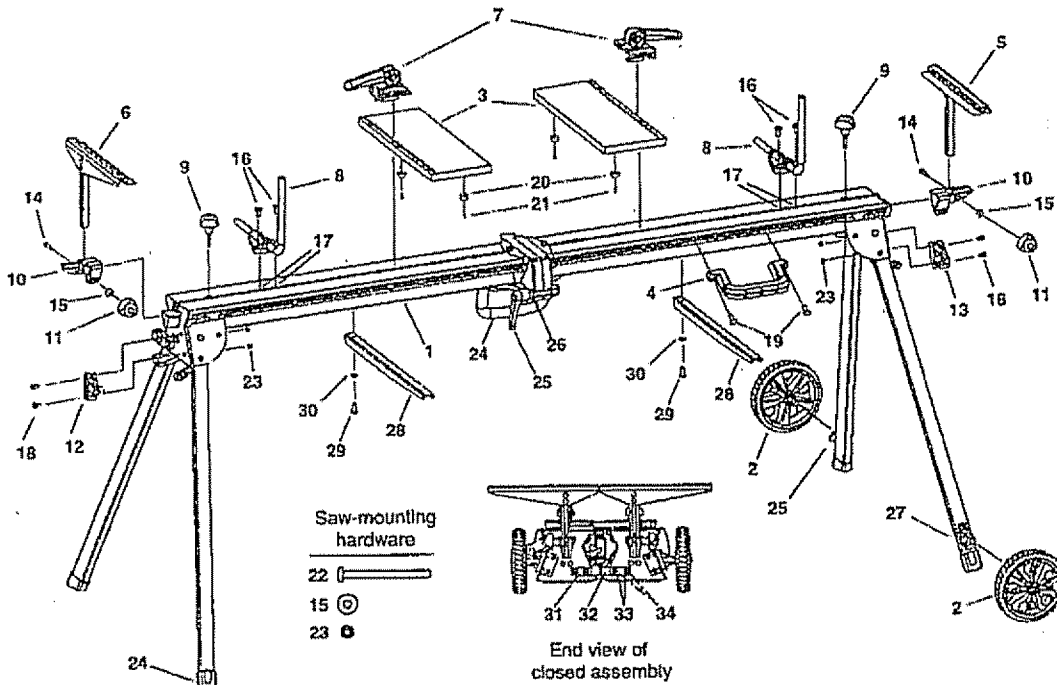

KEY NO.	ITEM	PART NO.	ORIGINAL PART DESCRIPTION	QTY.
1	A		Frame assembly	1
2	B	119 800 812	Wheel assembly	2
3	C	117 910 010	Mounting board	2
4	D	116 600 727	Carrying handle	1
5	E	119 800 814	Work support assembly, right	1
6	F	119 800 295	Work support assembly, left	1
7	G	119 900 124	Clamp assembly	2
8	H	119 800 813	Edge guide assembly	2
9	J	119 800 296	Extension knob assembly	2
10	K	119 800 297	Work support connector assembly	2
11	L	119 800 279	Work support knob	2
12	M	119 800 819	Wheel support assembly, right	1
13	N	119 800 820	Wheel support assembly, left	1
14	P	116 720 021	Work support knob screw (M6x35)	2
15	Q	116 720 077	Work support knob/Saw-mounting washer (6.4)	6
16	R	116 710 100	Edge guide-mounting screw (M8x16)	4
17	S	116 720 103	Edge guide-mounting square nut (M8)	4
18	T	116 700 200	Wheel support mounting screw (M6x12)	4
19	U	116 700 174	Carrying handle-mounting screw (M8x20)	2
20	V	116 610 094	Rubber foot for mounting board	4
21	W	116 730 101	Rubber foot-mounting screw (M4x16)	4
22	X	116 730 100	Saw-mounting screw (M6x70)	4
23	Y	116 700 024	Saw-mounting/Wheel support nut (M6)	8

REPAIR PARTS

PARTS LIST

Universal Professional Miter Saw Stand Model No. 695.22302

KEY NO.	PART NO.	REPLACEMENT PARTS DESCRIPTION	QTY.
2	119 800 812	Wheel assembly	1
3	117 910 010	Mounting board	1
4	116 600 727	Carrying handle	1
19	116 700 174	Carrying handle-mounting screw (M8x20)	2
5	119 800 814	Work support assembly, right	1
6	119 800 295	Work support assembly, left	1
10	119 800 297	Work support connector assembly	1
11	119 800 279	Work support knob	1
14	116 720 021	Work support knob screw (M6x35)	1
15	116 720 077	Work support knob washer (6.4)	1
7	119 900 124	Clamp assembly	1
8	119 800 813	Edge guide assembly	1
16	116 710 100	Edge guide-mounting screw (M8x16)	2
17	116 720 103	Edge guide-mounting square nut (M8)	2
9	119 800 296	Extension knob assembly	1
20	116 610 094	Rubber foot for mounting board	4
21	116 730 101	Rubber foot-mounting screw (M4x16)	4
22	116 730 100	Saw-mounting screw (M6x70)	4
15	116 720 077	Saw-mounting washer (6.4)	8
23	116 700 024	Saw-mounting nut (M6)	4
12	119 800 819	Wheel support assembly, right	1
13	119 800 820	Wheel support assembly, left	1
18	116 700 200	Wheel support assembly mounting screw (M6x12)	1
23	116 700 024	Wheel support assembly-mounting nut (M6)	1
24	119 800 269	Swivel handle assembly (red)	1
25	116 610 228	Adjustable handle for latching frame together	1
26	116 710 050	Adjustable handle washer (10.4)	1
27	116 600 662	Foot	4
28	117 010 301	Stock support	1
29	116 730 069	Stock support screw (M6x16)	1
30	116 700 026	Stock support washer (6.4)	1
31	119 800 278	Carrying Lock, Right Hand	1
32	116 600 730	Carrying Lock, Left Hand	1
33	116 700 091	Carrying Lock Mounting Screw (M6x20)	4
34	116 700 024	Carrying Lock Mounting Nut (M6)	4



Get it fixed, at your home or ours!

Your Home

For repair in your home of all major brand appliances, lawn and garden equipment, or heating and cooling system, **no matter who made it, no matter who sold it!**

For the replacement parts, accessories and owner's manuals that you need to do-it-yourself.

For Sears professional installation of home appliances and the items like garage door openers and water heaters.

1-800-4-MY-HOME®
(1-800-469-4663)
www.sears.com

Anytime, day or night
(U.S.A. and Canada)
www.sears.com

Our Home

For repair of carry-in products like vacuums, lawn equipment, and electronic, call or go on-line for the nearest **Sears Parts and Repair Center.**

1-800-488-1222 Anytime, day or night (U.S.A.)
www.sears.com

To purchase a protection agreement (U.S.A.) or maintenance agreement (Canada) on a product serviced by Sears:

1-800-827-6655 (U.S.A.) **1-800-361-6665** (Canada)

Para pedir servicio de reparación a domicilio, y para ordenar piezas:

1-888-SU-HOGARSM
(1-888-784-6427)

Au Canada pour service en français:

1-800-LE-FOYER^{MC}
(1-800-533-6937)
www.sears.ca



© Sears, Roebuck and Co.

® Registered Trademark / ™ Trademark / SM Service Mark of Sears, Roebuck and Co.

® Marca Registrada / ™ Marca de Fábriica / SM Marca de Servicio de Sears, Roebuck and Co.

^{MC} Marque de commerce / ^{MC} Marque déposée de Sears, Roebuck and Co.