

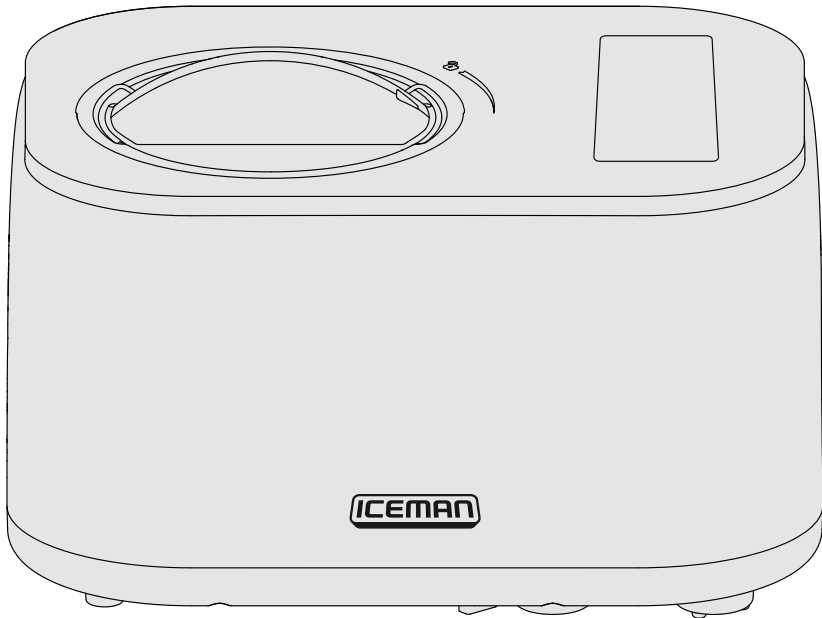

Ice Iceman Trio

Ice Cream,
Frozen Yogurt &
Italian Ice Maker



RJ64-10-V2-COLORS





Get to Know Your Ice Maker

1. Lid handle
2. Easy-view transparent lid
3. Paddle
4. Chilling bucket inserts (2)
5. Chilling cylinder
6. Motor base with compressor
7. Control panel
8. Storage lids (2)
9. Ice cream shovel
10. Ice cream scoop

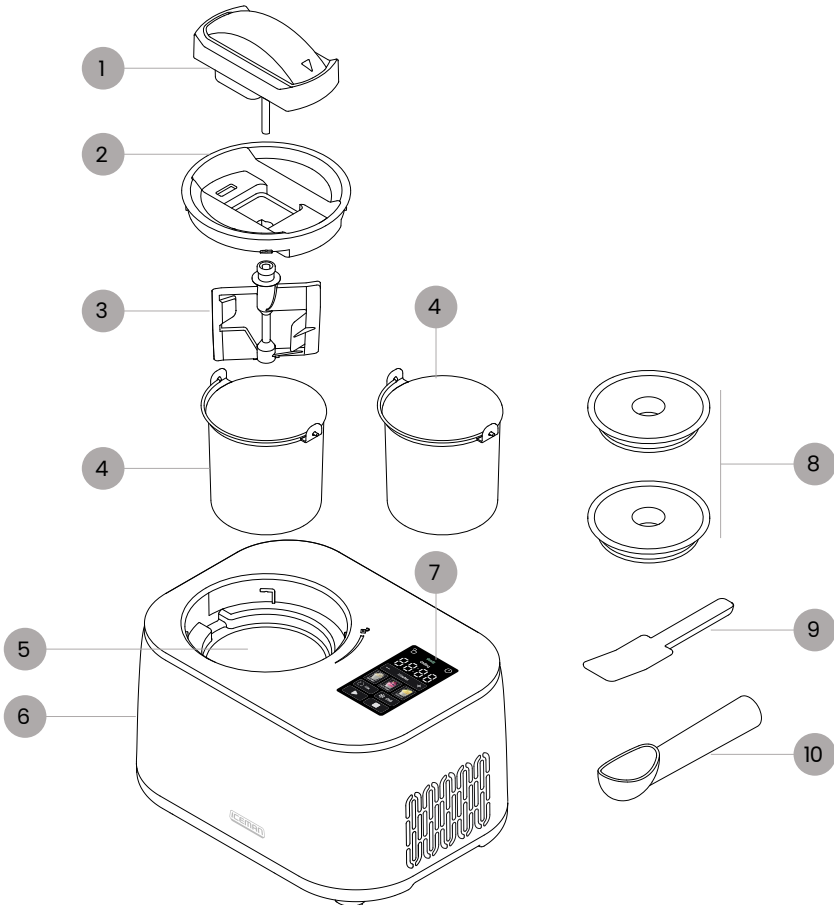



Control Panel

1. Lid unlocked indicator light
2. Ready indicator light
3. Chilling indicator light
4. Power button
5. Digital time display
6. Time + and - buttons
7. Preset buttons*
8. Chill button
9. Stop button
10. Start button
11. Mix button



*Press and hold the Frozen Yogurt button for 3 seconds while in Standby mode to mute the unit's beeps. Press and hold again to turn sound back on.



READ ALL INSTRUCTIONS BEFORE USE

For your safety and continued enjoyment of this product, always read the instruction manual before using.





SAFETY INSTRUCTIONS & IMPORTANT SAFEGUARDS

When using electrical appliances, basic safety precautions should always be followed, including:

1. Read all instructions.
2. Remove all bags and packaging from appliance before use.
3. Never leave appliance unattended when in use.
4. Make sure the appliance is cleaned thoroughly before using.
5. **Do NOT** use appliance for other than its intended use. For household use only. Do not use outdoors.
6. To prevent electric shock, do not submerge the cord, plugs, motor unit, or any electrical parts in water or any other liquid.
7. **Do NOT** operate this appliance with a damaged cord, damaged plug, after the appliance malfunctions, is dropped, or damaged in any manner. Contact Customer Support for replacement, examination, or repair.
8. **Do NOT** place appliance on or near a hot gas burner, hot electric burner, or in a heated oven.
9. Refrain from using attachments that are not recommended by Iceman, as this may result in fire, electric shock, or personal injury.
10. **Do NOT** let the cord touch hot surfaces, or hang over the edges of tables or counters.
11. This appliance can be used by persons with reduced physical, sensory, or mental capabilities or lack of experience or knowledge, if they have been given supervision or instruction concerning use of the appliance in a safe way and understand the hazards involved.
12. Children should be supervised not to play with the appliance.
13. Avoid contact with moving parts.
14. Always be sure to unplug the appliance from the outlet prior to moving, cleaning, storage, and when not in use.
15. Always place the unit on a firm and stable surface prior to use.
16. Improper use of the appliance can result in property damage or even in personal injury.





SAFETY INSTRUCTIONS & IMPORTANT SAFEGUARDS

17. Never use abrasive cleaning agents when cleaning this unit.
18. Unit should remain upright at all times. If unit is turned on its side or upside down, you will need to put it in upright position and wait 24 hours before using.

SAVE THESE INSTRUCTIONS FOR HOUSEHOLD USE ONLY

WARNING: Improper use of the grounding plug can result in electric shock.

Grounding Instructions

This appliance must be grounded. In the event of an electrical short circuit, grounding reduces the risk of electric shock by providing an escape wire for the electric current.

To protect against electrical shock, this appliance is equipped with a cord having a 3-prong grounding-type plug for insertion into a proper grounding-type electrical outlet. DO NOT alter the plug for use in a 2-prong outlet. If the plug will not fit into an outlet, have a proper outlet installed by a qualified electrician.



Warning: Risk of fire/
flammable materials





SAFETY INSTRUCTIONS & IMPORTANT SAFEGUARDS

Short Cord Instructions

A short power-supply cord is provided to reduce the hazards of entanglement or tripping over a longer cord. Longer detachable power-supply cords or extension cords are available and may be used if care is exercised in their use. If a longer detachable power-supply extension cord is used:

1. The marked electrical rating of the extension cord should be at least as great as the electrical rating of the appliance;
2. If the appliance is of the grounded type, the extension cord should be a grounding-type 3-wire cord; and
3. The longer cord should be arranged so that it will not drape over the countertop or tabletop where it can be pulled on by children or tripped over.

Power Cord Safety Tips

1. Never pull or yank on the cord or the appliance.
2. To insert the plug, grasp it firmly and guide it into the outlet.
3. To disconnect the appliance, grasp the plug and remove it from the outlet.
4. Never use the product if the power cord shows signs of abrasion or excessive wear. Contact Customer Support for additional guidance and support.
5. Never wrap the cord tightly around the appliance, as this could place undue stress on the cord where it enters the appliance and cause it to fray and break.

DO NOT OPERATE THE APPLIANCE IF THE POWER CORD SHOWS ANY DAMAGE OR IF THE APPLIANCE WORKS INTERMITTENTLY OR STOPS WORKING ENTIRELY.



California Proposition 65:

(Applicable for California Residents only)
WARNING: Cancer and Reproductive Harm
www.P65Warnings.ca.gov

Do not place the appliance on a stovetop or any other heatable surface, even if stovetop is not on. Doing so is a fire hazard.





Before First Use



1. Remove all packaging materials and check to ensure that all parts and accessories are accounted for. Read and remove all stickers (except for the rating label, which should remain on the unit).
2. Set the unit upright on a flat surface. Let it stand for at least 2 hours before using, to allow the refrigerant to settle.
3. Remove and hand wash the chilling buckets, paddle, transparent lid, lid handle, storage lids, as well as the ice cream scoop and shovel.
4. Wipe down the unit housing with a soft, damp cloth. Do not immerse the unit in water or any other liquid. Never use abrasive cleaning agents, which can damage the finish.





How to Use the Ice Cream Maker

1. Prepare your ice cream, Italian ice, or frozen yogurt base and pour it into one of the chilling buckets. **NOTE:** Do not exceed the appropriate **Max** line for what you are making (**Max 1** for Italian ice; **Max 2** for frozen yogurt and ice cream). For the best results, make sure your mixture is chilled (room temperature is OK too). Never use the unit to chill hot liquids.

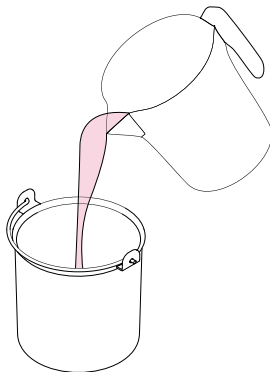

2. Plug in the ice cream maker and lower the bucket into the chilling cylinder, making sure the two tabs on the side of the bucket are aligned with the notches in the cylinder housing.

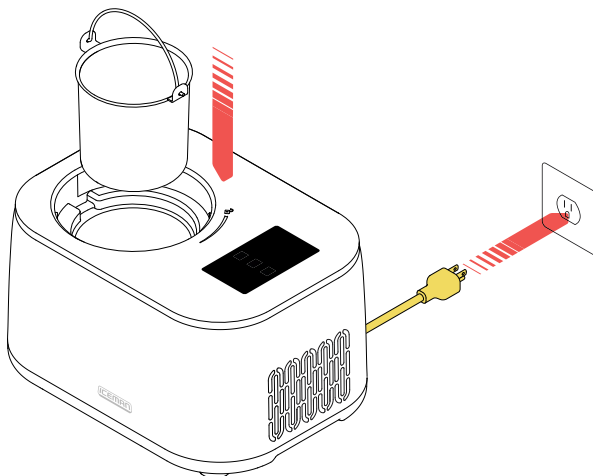



How to Use the Ice Cream Maker

3. Snap the lid handle onto the transparent lid. Insert the spindle on the lid into the end of the paddle with a collar, then press until they click together.

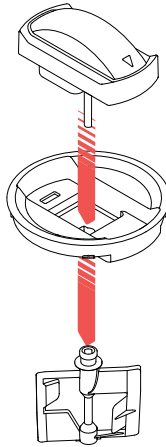

4. Lower the lid/paddle assembly into the bucket, aligning the arrow on the lid handle with the unlock icon on the unit.

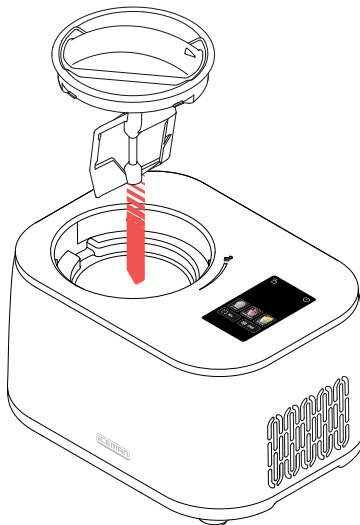



How to Use the Ice Cream Maker

5. Turn the lid handle clockwise to lock the lid in place; you'll feel and hear a click, and the **Lid unlocked indicator light** on the control panel will turn off.

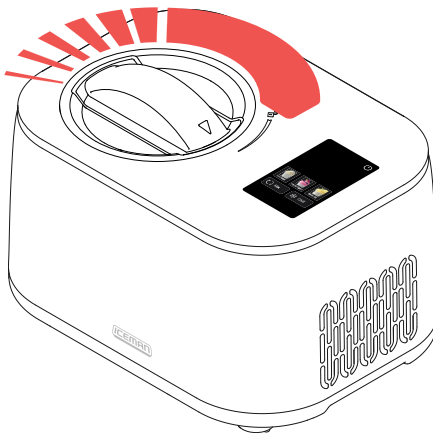

6. Select your chosen preset (see details p. 12). If desired, use the + and – buttons to adjust the time up or down, to a maximum of 60 minutes, depending on preset. Press **Start**.

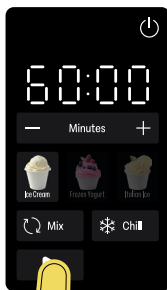



How to Use the Ice Cream Maker

7. The unit will begin churning and counting down the remaining time in the cycle. If you want to check on your ice cream at any time, press the **Stop** button; the churning will pause, and you can either look through the transparent lid, or unlock and remove the lid to check consistency. To resume the cycle, press **Start** again.
8. When the cycle finishes, the unit will beep and automatically switch to Chill mode (the **Chilling** and **Ready** indicator lights will illuminate). The paddle will stop churning but the unit will keep your ice cream cold until you remove it, for up to 60 minutes. If desired, use the Mix function to add your mix-ins at this point (see p. 12 for more details). **IMPORTANT:** If the unit detects that the ice cream has reached the right consistency before the programmed time, it will stop churning, the word "dENSE" will scroll across the digital display, "Ready" will illuminate, and the unit will switch to Chill mode.
9. Unlock and remove the lid/paddle assembly and lift the bucket out of the unit. At the end of the freezing cycle, your frozen treat will have a soft-serve consistency.
10. To achieve the typical "hard-pack" ice cream consistency, put one of the storage lids on the bucket (or transfer to a separate lidded freezing container) and place in your freezer for at least 4 hours.

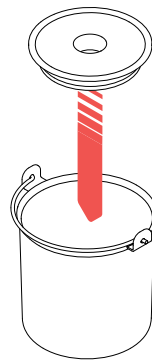
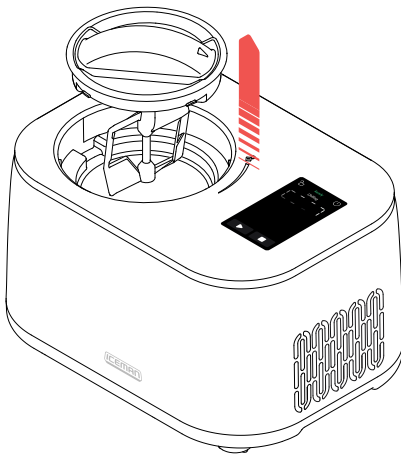



Presets & Special Functions

The three presets offer preprogrammed typical times for different types of frozen treats. Because some types of frozen treats expand more than others, there are also two different **Max** fill lines depending on what you're making.

Preset	Max Fill Line	Default Run Time	Use it for
Ice Cream	Max 2 Line	35 minutes	Traditional cooked and no-cook ice cream bases, sorbets, and sherbets
Frozen Yogurt	Max 2 Line	30 minutes	A creamy, tangy yogurt treat with higher protein and lower fat, perfect for flavoring with fruit and honey
Italian Ice	Max 1 Line	35 minutes	Sweetened fruit juices, fruit syrups

Chill function

In Chill mode, the unit chills the ice cream but does not mix it. When your chosen preset finishes, the unit switches automatically to Chill mode to keep your ice cream cold for up to 60 minutes. Chill mode means you don't need to hover over the unit to immediately transfer to the freezer when it's finished processing. You can also use the Chill function on its own. With the unit powered on, simply press **Chill** and use the +/- buttons to adjust the time up to 30 minutes, then press **Start**.

Mix function

In Mix mode, the unit stirs the ice cream mixture but does not chill it, making this function ideal for blending in mix-ins after an ice cream or frozen yogurt finishes processing. (It can also be used to mix together liquid ingredients before the freezing cycle.) To use it, unlock and remove the lid/paddle assembly, then add up to ¾ cup of mix-in(s) to the bucket. Return the lid/paddle to the bucket and lock it. Press **Mix**, then adjust the time between 1 and 5 minutes using the + and - buttons. Press **Start**; the unit will begin mixing and counting down the time. Be careful not to overmix, especially with crumbly mix-ins such as cookies—many take only a minute or two to fully incorporate. When the Mix cycle finishes, press **Chill** to return to Chill mode OR transfer the finished ice cream to the freezer. **NOTE:** If your unit has entered Chill mode with a "dENSE" alert because it froze sufficiently before the estimated time, it will not run a mix cycle for more than a few seconds. In this case, remove the ice cream from the bucket and fold in the mix-ins by hand.





Ice Cream, Frozen Yogurt & Italian Ice Tips

- Frozen treats expand in volume as they freeze, so be sure to fill the bucket only to the appropriate **Max** line to prevent overflow. Italian ice expands more than ice cream or frozen yogurt, so its **Max** line (**Max 1**) is lower.
- Before processing, always make sure the cylinder and outside of the bucket are completely dry. Any moisture in between the two can freeze during the chilling cycle, causing the bucket to get stuck inside the cylinder.
- Homemade ice cream will keep well in the freezer for up to 1 week; after that it tends to develop ice crystals. To maximize storage time, press parchment or waxed paper over the surface of the ice cream before putting the lid on.
- Ice creams with cooked (custard) bases, or simple stir-together dairy (and dairy-alternative) bases both work well in the ice cream maker.
- For cooked bases, strain the custard before processing to remove any bits of cooked egg.
- For the creamiest texture, let ice creams with cooked bases chill in the refrigerator or an ice bath before processing in the unit. If you're pressed for time, you can start processing when the mixture is at room temperature (adding time to the cycle as needed) but NEVER begin processing the base while it is still hot.
- Sorbets (made from pureed fruit) work best on the ice cream setting, which yields a smooth, scoopable result. Thinner fruit juice bases should be processed on the Italian ice preset, which will yield a granita-like texture.
- The proportion of sugar vs fat in your specific recipe or the inclusion of any alcoholic ingredients can affect the time it takes to fully freeze. If the ice cream hasn't frozen adequately after 75 minutes, the base may have too much sugar or alcohol.
- If finished ice cream has an icy texture, the base may be too low in sugar or fat.
- If the finished ice cream has a thick, waxy mouthfeel, the base may be too high in fat.
- Chill mode keeps your frozen treat cold until you are able to transfer it to the freezer for further hardening. As the ice cream sits in Chill mode, the sides begin to harden up while the inside stays soft, so we recommend transferring it to the freezer as soon as possible for the most even freezing.



Creating Flavors

A good basic ice cream or frozen yogurt can be transformed into dozens of flavors with the addition of extracts, fruit purees, or cocoa or espresso powder. Start with the base of your choice (see below), then use the amounts in this chart as a guideline. Chunky mix-ins should be added using the **Mix** function (see p. 12) after the ice cream finishes processing; other flavorings should be stirred into the base before processing. **NOTE:** Avoid large amounts of thin liquid mix-ins, which will create an icy texture.

Flavoring	Recommended amount (per 2-cup batch)	Notes
Extracts (e.g., vanilla, lemon, orange, mint, coconut)	1 – 2 tsp	A little vanilla extract enhances certain flavors like chocolate or coffee but can clash or compete with other flavors.
Fruit puree (e.g., raspberry, strawberry, peach)	¾ – 1 cup	Work best with no-cook dairy bases. For more concentrated flavor, cook fruit until softened, then puree.
Cocoa powder	3 Tbsp	Dutch-process cocoa, such as Hershey's Special Dark, mixes best into bases without clumping.
Instant espresso powder	1–2 Tbsp	
Chunky mix-ins (e.g., crushed cookies or candies, chocolate chips)	½ cup – ¾ cup	Add using the Mix function after the ice cream is fully processed.

3 Tasty Bases

Sweet Cream Ice Cream: Whisk together **1 cup heavy cream**, **¾ cup whole milk**, and **2/3 cup sugar**, along with desired flavorings. Process on **Ice Cream**.

Tangy Frozen Yogurt: Whisk together **2 cups plain, whole-milk Greek yogurt** and **1 cup sugar**, along with any desired flavorings. Process on **Frozen Yogurt**.

Citrus Italian ice: Whisk **½ cup sugar** in **2/3 cup warm water** until dissolved. Add **1/3 cup plus 2 Tbsp fresh lemon or lime juice** (or a mix) and **¾ cup cold water**. Process on **Italian Ice**. **NOTE:** Due to its unique texture and sugar requirements, Italian ice is only compatible with extracts or powdered flavorings, not fruit purees or mix-ins.



Scan here for a digital cookbook full of delicious recipes created by our expert chefs especially for your Iceman Trio Ice Cream, Frozen Yogurt & Italian Ice Maker.



Keep It Clean

1. Unplug the unit and let the chilling cylinder warm to room temperature before cleaning.
2. **IMPORTANT:** The transparent lid and lid handle must be separated before cleaning; press in the two tabs on the underside of the handle, then pull the lid and handle apart.

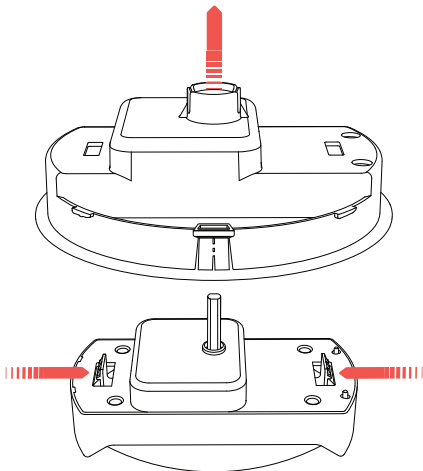

3. Wipe down the unit housing, lid handle, and the chilling cylinder with a damp cloth. Do not use abrasive cleaners, as they may damage the finish. Never immerse the unit housing or lid handle in water or any other liquid.
4. Wash the chilling bucket inserts, transparent lid, and paddle in warm soapy water, then rinse and dry with a soft cloth. These parts are also top-rack dishwasher safe.
5. The storage lids, ice cream shovel, and ice cream scoop are also dishwasher safe.





Having Trouble?

Problem	Likely Cause	Solution
Chilling bucket insert is stuck in chilling cylinder after freezing.	The bucket and cylinder have frozen together due to moisture in between them.	Press the Stop button to turn off the Chill mode; wait a few minutes, then try to separate again.
Unit goes into Chill mode before timer has counted down and "dENSE" scrolls across display.	The ice cream has frozen sufficiently ahead of the estimated time.	This is normal.
Mix mode runs for only a few seconds then turns off, with "dENSE" alert scrolling across display.	To protect the motor, the unit turns off Mix mode if it has just automatically ended a preset cycle with the "dENSE" alert.	This is normal, but if you would like to add mix-ins to your ice cream, remove it from the chilling cylinder and fold them in by hand.
Time is up but mixture isn't frozen/firm enough.	<ol style="list-style-type: none"> 1. Base needs additional time due to higher sugar or alcohol content. 2. The unit is designed to produce ice cream that is a soft-serve consistency. 	<ol style="list-style-type: none"> 1. Add additional time to the processing cycle. If after 75 minutes it still hasn't frozen, the sugar or alcohol content may be too high. 2. To firm up ice cream to hard-pack consistency, cover bucket and transfer to freezer for about 4 hours.
Timer is counting down, but paddle is not churning.	<ol style="list-style-type: none"> 1. Paddle is not properly attached to lid. 2. Lid is not completely locked. 3. Food residue is blocking the electrical contact points on the unit so it doesn't detect the lid. 	<ol style="list-style-type: none"> 1. Remove and re-install paddle. 2. Remove and re-install lid. It must audibly click to be fully locked. 3. Power off the unit and clean the electrical contact points: two small silver circles above the chilling cylinder, on either side of where the lid handle rests when locked.



Terms & Conditions

Limited Warranty

RJ Brands, LLC d/b/a Chefman™ offers a limited 1-year Warranty (the “Warranty”) available on sales through authorized distributors and retailers only. Please note that this Warranty becomes valid from the date of initial retail purchase and that the Warranty is nontransferable and applies only to the original purchaser.

This Warranty is void without proof of purchase within the United States and Canada. Please be aware that this Warranty supersedes all other warranties and constitutes the entire agreement between the consumer and Chefman™. Any changes to the Terms and Conditions of this Warranty must be in writing, signed by a representative of Chefman™. No other party has the right or ability to alter or change the Terms and Conditions of this Warranty.

We may ask you to please submit, via email, photos and/or video of the issue you are experiencing. This is to help us better assess the matter and possibly offer a quick fix. Photos and/or video may also be required to determine Warranty eligibility.

We encourage you to register your product. Registering can make the Warranty process easier and can keep you informed of any updates or recalls on your product. To register, follow the directions on the Chefman® Warranty Registration page in the Chefman™ User Guide. Please retain your proof of purchase even after registering. In the event that you do not have proof of your purchase date, we may declare your Warranty void or we may, at our sole discretion, apply the date of manufacture as the purchase date for purposes of this Warranty.





Terms & Conditions

What the Warranty Covers

- **Manufacturer Defects**

Chefman™ products are warranted against defects in material and workmanship, under normal household use, for a period of 1 year from the date of purchase when used in accordance with the directions listed in the Chefman™ User Guide. If your product does not work as it should, please contact Customer Support at Chefman.com so that we may assist you.

This Warranty Does Not Cover

- **Misuse**

Damage that occurs from neglectful or improper use of products, including, but not limited to, damage that occurs as a result of usage with incompatible voltage, regardless of whether the product was used with a converter or adapter. See Safety Instructions in the Chefman™ User Guide for information on proper use of product;

- **Poor Maintenance**

General lack of proper care. We encourage you to take care of your Chefman™ products so that you may continue to enjoy them. Please see Keep It Clean directions in this Chefman™ User Guide for information on proper maintenance;

- **Commercial Use**

Damage that occurs from commercial use;

- **Normal Wear and Tear**

Damage or degradation expected to occur due to normal use over time;

- **Altered Products**

Damage that occurs from alterations or modifications by any entity other than Chefman™ such as the removal of the rating label affixed to the product;

- **Catastrophic Events**

Damage that occurs from fire, floods, or natural disasters; or

- **Loss of Interest**

Claims of loss of interest or enjoyment.





Terms & Conditions

For product information, please visit us at Chefman.com.

EXCEPT WHERE SUCH LIABILITY IS REQUIRED BY LAW, THIS WARRANTY DOES NOT COVER, AND CHEFMAN™ SHALL NOT BE LIABLE FOR, INCIDENTAL, INDIRECT, SPECIAL, OR CONSEQUENTIAL DAMAGES, INCLUDING WITHOUT LIMITATION, DAMAGE TO, OR LOSS OF USE OF THE PRODUCT, OR LOST SALES OR PROFITS OR DELAY OR FAILURE TO PERFORM THIS WARRANTY OBLIGATION. THE REMEDIES PROVIDED HEREIN ARE THE EXCLUSIVE REMEDIES UNDER THIS WARRANTY, WHETHER BASED ON CONTRACT, TORT OR OTHERWISE.



Warranty Registration

What do I need to register my product?

- Contact Information
- Model Number (see example below)
- Proof of Purchase (online confirmation, receipt, gift receipt)
- Date Code (see example below)
- Access Code (see example below)



→ **Model/Modelo:** XXXXX
 Ice Maker
 120v~60hz 1800W
 CONFORMS TO UL STD. 1026
 CERTIFIED TO CSA STD.C22.2 No.64
 CAUTION: DO NOT IMMERSE IN WATER
 ATTENTION: NE PAS PLONGER DANS L'EAU
 WARNING: TO PREVENT ELECTRIC SHOCK,
 UNPLUG BEFORE CLEANING
 PRÉAVIS: POUR ÉVITER LES CHOCS ÉLECTRIQUES,
 DÉBRANCHEZ L'APPAREIL AVANT DE L'UTILISER
 READ INSTRUCTIONS BEFORE USING
 LISEZ LES INSTRUCTIONS AVANT DE L'UTILISER
 HOUSEHOLD USE ONLY
 POUR USAGE DOMESTIQUE SEULEMENT

Date Code:
0000 ←
Access Code:
Xxxxxxxx ←

NOTE: Label depicted here is an example.

Please see label on your product for actual model/date code/access code.

How do I register my product?

All you need to do is fill out a simple Chefman™ registration form. You can easily access the form in one of the two ways listed below:

- Visit Chefman.com.
- Scan the QR code to the right to access site.





Iceman Trio

Ice Cream, Frozen Yogurt
& Italian Ice Maker

RJ6410/V2-COLORS-UG11E25

Iceman™ is a trademark of RJ Brands, LLC.
Chefman™ is a trademark of RJ Brands, LLC.

