

# SOLAR SUITCASE

Renogy Solar Suitcase w/ Voyager

200W





Version 2.0



## **Important Safety Instructions**

Please save these instructions.

This manual contains important safety, installation, and operating instructions for the charge controller. The following symbols are used throughout the manual to indicate potentially dangerous conditions or important safety information.

- |  |   |
|--|---|
|  <b>WARNING</b> | Indicates a potentially dangerous condition. Use extreme caution when performing this task.             |
|  <b>CAUTION</b> | Indicates a critical procedure for safe and proper operation of the controller                          |
|  <b>NOTE</b>    | Indicates a procedure or function that is important to the safe and proper operation of the controller. |

### **General Safety Information**

- Read all the instructions and cautions in the manual before beginning the installation.
- There are no serviceable parts for this controller. Do NOT disassemble or attempt to repair the controller.
- Make sure all connections going into and from the controller are tight.

### **Battery Safety**

- Use only sealed lead-acid, flooded, gel or lithium batteries which must be deep cycle.
- Explosive battery gases may be present while charging. Be certain there is enough ventilation to release the gases.

- Be careful when working with large lead-acid batteries. Wear eye protection and have fresh water available in case there is contact with the battery acid.
- Carefully read battery manuals before operation.
- Do NOT let the positive (+) and negative (-) terminals of the battery touch each other.
- Recycle battery when it is replaced.
- Over-charging and excessive gas precipitation may damage the battery plates and activate material shedding on them. Too high of an equalizing charge or too long of one may cause damage. Please carefully review the specific requirements of the battery used in the system.
- Equalization is carried out only for non-sealed / vented / flooded / wet cell lead-acid batteries.
- **Do NOT equalize sealed / VRLA type AGM / Gel cell batteries UNLESS permitted by the battery manufacturer.**

# Table of Contents

General Information .....	04
Included Components .....	06
Identification of Parts .....	06
Installation .....	08
Operation .....	10
Selecting Battery Type .....	10
AMP/VOLT Button .....	11
LED Display .....	11
System Status Icons .....	12
LED Behavior .....	12
LED Error Behavior .....	12
System Status Troubleshooting .....	13
Maintenance .....	13
Frequently Asked Questions .....	14
Technical Specifications .....	14
Solar Panel Parameters .....	14
Charge Controller Parameters .....	15
Battery Charging Parameters .....	16
Charging Parameters Glossary .....	16
Dimensions .....	17

## General Information

The Renogy Solar Suitcase combine highly efficient monocrystalline solar panels with a 20A Voyager charge controller to create an easy-to-use, 'plug and play' system.

This system is specifically designed for mobile off-grid applications, where space and weight limitations are abundant. The Solar Suitcase models support 12V deep cycle battery varieties such as sealed-lead acid, gel, and flooded. With built-in tilting stands, these panels can be adjusted at different angles to maximize the power output throughout the seasons.

The alligator clips included in this package make it easy to connect the panel to a battery in seconds. If one ever needs to connect a battery with a different type of end terminal, the alligator clips are attached via MC4 Connectors.

### Key Features

- Easy to read LCD displaying solar charge information
- 7 Battery Type Compatible – Lithium-ion, LiFePO4, LTO, Gel, AGM, Flooded, and Calcium
- 4 Stage charging: Bulk, Boost, Float, and Equalization
- Temperature compensation and correcting the charging and discharging parameters automatically, improving battery lifetime.
- Protection against: overcharging, over-discharging, overload, short-circuit, and reverse polarity.
- Negative ground controller.
- Tilting stand for maximum solar generating potential.
- Convenient storage case for easy transportation.

### PWM Technology

The Voyager utilizes Pulse Width Modulation (PWM) technology for battery charging. Battery charging is a current based process so controlling the current will control the battery voltage. For the most accurate return of capacity, and for the prevention of excessive gassing pressure, the battery is required to be controlled by specified voltage regulation set points for Absorption, Float, and Equalization charging stages. The charge controller uses automatic duty cycle conversion, creating pulses of current to charge the battery. The duty cycle is proportional to the difference between the sensed battery voltage and the specified voltage regulation set point. Once the battery reached the specified voltage range, pulse current charging mode allows the battery to react and allows for an acceptable rate of charge for the battery level.

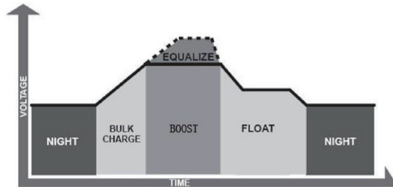

## Four Charging Stages

The Adventurer has a 4-stage battery charging algorithm for a rapid, efficient, and safe battery charging. They include: Bulk Charge, Boost Charge, Float Charge, and Equalization.

**Bulk Charge:** This algorithm is used for day to day charging. It uses 100% of available solar power to recharge the battery and is equivalent to constant current.

**Boost Charge:** When the battery has charged to the Boost voltage set-point, it undergoes an absorption stage which is equivalent to constant voltage regulation to prevent heating and excessive gassing in the battery. The Boost time is 120 minutes.

**Float Charge:** After Boost Charge, the controller will reduce the battery voltage to a float voltage set point. Once the battery is fully charged, there will be no more chemical reactions and all the charge current would turn into heat or gas. Because of this, the charge controller will reduce the voltage charge to smaller quantity, while lightly charging the battery. The purpose for this is to offset the power consumption while maintaining a full battery storage capacity. In the event that a load drawn from the battery exceeds the charge current, the controller will no longer be able to maintain the battery to a Float set point and the controller will end the float charge stage and refer back to bulk charging.

**Equalization:** Is carried out every 28 days of the month. It is intentional overcharging of the battery for a controlled period of time. Certain types of batteries benefit from periodic equalizing charge, which can stir the electrolyte, balance battery voltage and complete chemical reaction. Equalizing charge increases the battery voltage, higher than the standard complement voltage, which gasifies the battery electrolyte.

### WARNING

Once equalization is active in the battery charging, it will not exit this stage unless there is adequate charging current from the solar panel. There should be NO load on the batteries when in equalization charging stage.

### WARNING

Over-charging and excessive gas precipitation may damage the battery plates and activate material shedding on them. Too high of equalizing charge or for too long may cause damage. Please carefully review the specific requirements of the battery used in the system.

### WARNING

Equalization may increase battery voltage to a level damaging to sensitive DC loads. Ensure that all load allowable input voltages are greater than the equalizing charging set point volta.

## Included Components



### MC4 to Alligator Clips w/ Fuse

Used for connecting charge controller to battery. The entire cable from the charge controller to the alligator clips measures 9.9 feet with an in-line fuse of 15A .

## Optional Components

Optional components that require a separate purchase:



### Remote Temperature Sensor

Measures the temperature at the battery and uses this data for very accurate temperature compensation. The sensor is supplied with a 9.9 feet cable length that connects to the charge controller.

## Identification of Parts

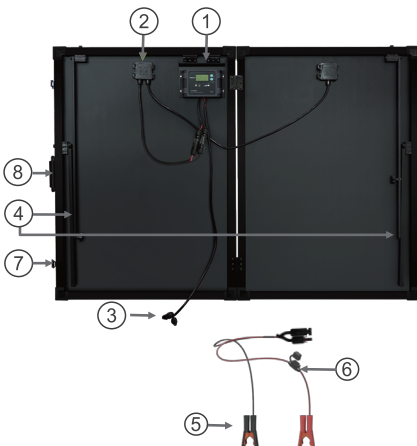

### ■ Key Parts

1. 20A Voyager Charge Controller
2. Junction Box
3. MC4 Connectors
4. Tilt Stands
5. Battery Alligator Clips
6. In-line fuse (15A)
7. Latch
8. Handle
9. Case (Not pictured)

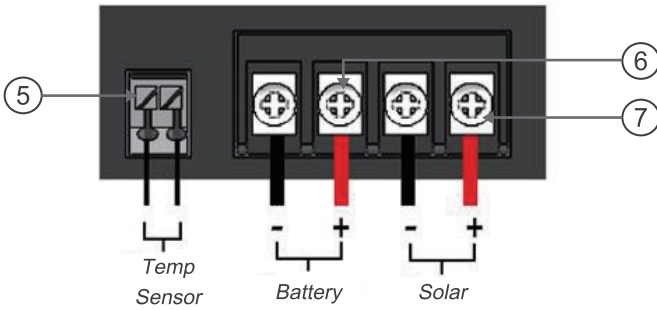
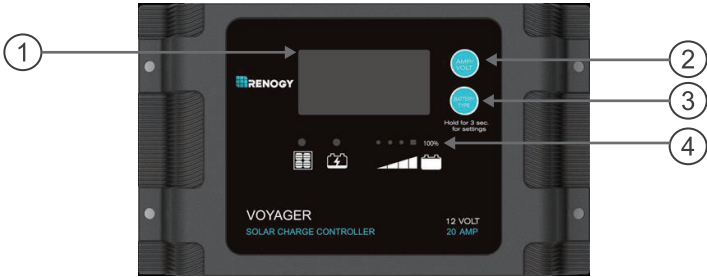

## ■ Key Parts

1. Backlit LCD
2. AMP/VOLT Button
3. BATTERY TYPE Button
4. LED Bar
5. Remote Temperature Sensor Port
6. Battery Terminals
7. Solar Terminals

# Installation

## 1. Unlatch and unfold unit then connect MC4 Connectors

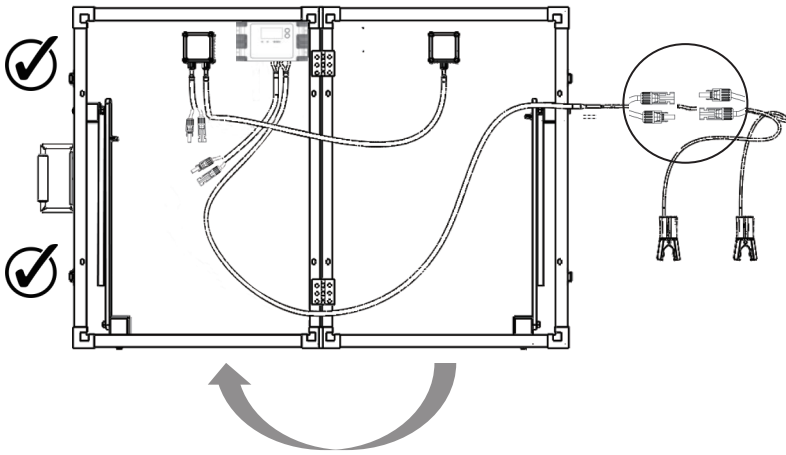

## 2. Connect Battery Alligator Clips to 12V Battery

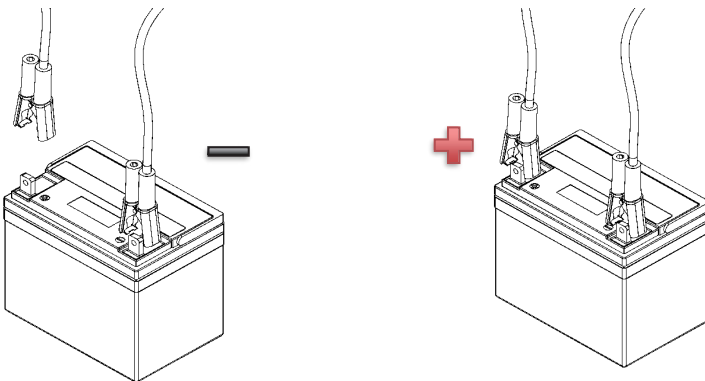

---

### 3. Unscrew butterfly nut tilt to desired angle and lock butterfly nut

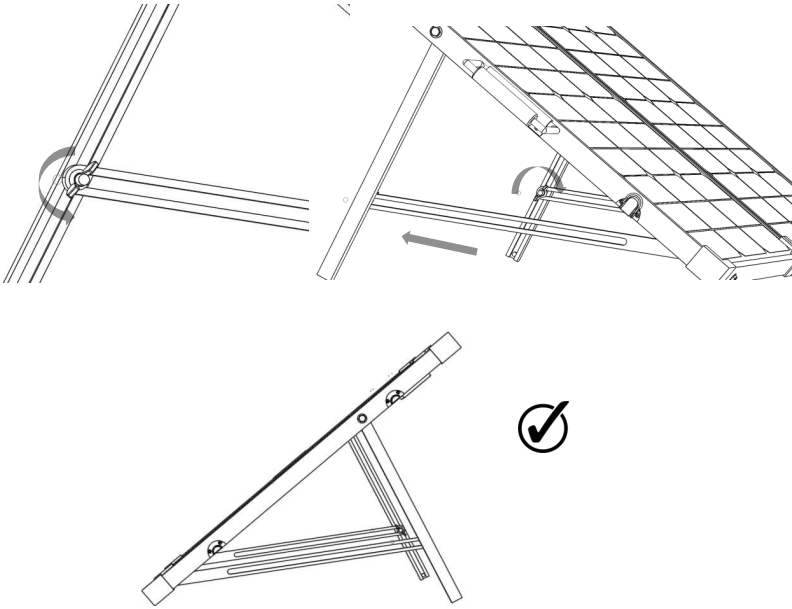



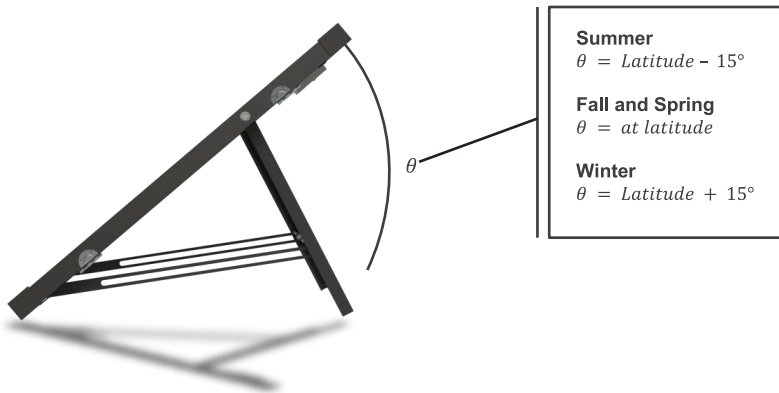

To maximize the output, adjust the angle of the suitcase regularly to track the sun's movement throughout the season



# Operation

When the controller powers on, the Voyager will run a self-quality check mode and automatically display the figures on LCD before going into auto work.

	Self-test starts, digital meter segments test
	Software version test
	Rated voltage Test
	Rated Current Test
	External battery temperature sensor test (if connected)

## Selecting Battery Type

**WARNING**

**Incorrect battery type setting may damage your battery. Please check your battery manufacturer's specifications to when selecting battery type.**

The Voyager provides 7 battery types for selection: Lithium-ion, LiFePO4, LTO, Gel, AGM, Flooded, and Calcium Battery.

Press and hold the BATTERY TYPE Button for 3 seconds to go into battery selection mode. Press the BATTERY TYPE Button until the desired battery is displayed. After a few seconds, the highlighted battery type will automatically be selected.

**NOTE**

**Lithium ion batteries shown in the LCD indicate different types shown below:**

- o Lithium Cobalt Oxide LiCoO<sub>2</sub> (LCO) battery
- o Lithium Manganese Oxide LiMn<sub>2</sub>O<sub>4</sub> (LMQ) battery
- o Lithium Nickel Manganese Cobalt Oxide LiNiMnCoO<sub>2</sub> (NMC) battery
- o Lithium Nickel Cobalt Aluminum Oxide LiNiCoAlO<sub>2</sub> (NCA) battery

**LiFePO<sub>4</sub> battery indicates Lithium-iron Phosphate or LFP Battery**

**LTO Battery indicates Lithium Titanate Oxidized, Li<sub>4</sub>Ti<sub>5</sub>O<sub>12</sub> Battery**

---

### AMP/VOLT Button

Pressing the AMP/VOLT Button will sequence through the following display parameters: Battery Voltage, Charging Current, Charged Capacity (Amp-hour), and Battery Temperature (if external temperature sensor connected)

### Normal Sequencing Display



NOTE

The following is an alternative display voltage for when the battery is Fully charged

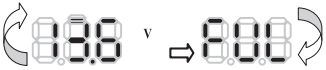

### LED Display



# System Status Icons

## LED Behavior

NOTE

BV = Battery Voltage

LED Indicators						
LED Color	<b>RED</b>	<b>BLUE</b>	<b>RED</b>	<b>ORANGE</b>	<b>GREEN</b>	<b>GREEN</b>
Soft-charging	ON	FLASH	OFF	OFF	OFF	OFF
Bulk charging ( BV < 11.5V )	ON	ON	OFF	OFF	OFF	OFF
Bulk charging ( 11.5V < BV < 12.5V )	ON	ON	OFF	OFF	OFF	OFF
Bulk charging ( BV > 12.5V )	ON	ON	OFF	OFF	ON	OFF
Absorption charging	ON	ON	OFF	OFF	ON	OFF
Float charging	ON	OFF	OFF	OFF	OFF	ON
Solar weak ( Dawn or Dusk )	FLASH	OFF	According to BV			OFF
In the night	OFF	OFF				OFF

## LED Error Behavior

LED Indicators							Error Code	Screen
LED Color	<b>RED</b>	<b>BLUE</b>	<b>RED</b>	<b>ORANGE</b>	<b>GREEN</b>	<b>GREEN</b>		
Solar good, BV<3V	ON	OFF	FLASH	OFF	OFF	OFF	'b01'	FLASH
Solar good battery reversed	ON	OFF	FLASH	OFF	OFF	OFF	'b02'	FLASH
Solar good, battery over-voltage	ON	OFF	FLASH	FLASH	FLASH	OFF	'b03'	FLASH
Solar off, battery over-voltage	OFF	OFF	FLASH	FLASH	FLASH	OFF	'b03'	FLASH
Solar good, battery over 65 C	ON	OFF	FLASH	FLASH	FLASH	OFF	'b04'	FLASH
Battery good, solar reversed	FLASH	OFF	According to BV			OFF	PO1	FLASH
Battery good, solar over-voltage	FLASH	OFF				OFF	PO2	FLASH
Over Temperature Protection							'otP'	FLASH

## System Status Troubleshooting

Description	Troubleshoot
Battery over voltage	Use a multi-meter to check the voltage of the battery. Make sure the battery voltage is not exceeding the rated specification of the charge controller. Disconnect battery.
Charge controller does not charge during daytime when the sun is shining on the solar panels.	Confirm that there is a tight and correct connection from the battery bank to the charge controller and the solar panels to the charge controller. Use a multi-meter to check if the polarity of the solar modules has been reversed on the charge controller's solar terminals.
Everything is connected correctly, but the LCD on the controller does not turn on	Check the rated battery voltage. The LCD will not display on the charge controller unless there is at least 9V coming from the battery bank.

## Maintenance

For best controller performance, it is recommended that these tasks be performed from time to time.

1. Check wiring going into the charge controller and make sure there is no wire damage or wear.
2. Tighten all terminals and inspect any loose, broken, or burnt up connections
3. Make sure readings in the LCD and LED are consistent.

## Frequently Asked Questions

### Q. Can the kit charge two or more 12V batteries connected in parallel?

A. Yes, it's possible if the batteries have the same type and capacity and are wired in parallel as a single 12V battery bank.

### Q. Is there any risk that the solar kit will overcharge my battery?

A. One of the functions of the solar charge controller is to ensure that your battery is not overcharged; therefore there is no risk of overcharge.

### Q. Can I extend the battery leads?

A. Yes, it's possible – please choose the same size of cable for extension. However, the longer the extension, the greater the line loss. A bigger gauge will be required for longer runs.

### Q. Do I need to clean the solar panels?

A. Yes, it is recommended for better performance. Dust and dirt should first be swept off the panel surface using a soft brush. When the sweeping is complete, use a wet cloth to wipe the panel surface to remove the remaining dirt and grime.

### Q. Can rain damage the solar kit?

A. The solar panels and charge controller are both fully waterproof (IP66, IP65).

## Technical Specifications

### Solar Panel Parameters

Description	Parameters
Power	200 W
Open Circuit Voltage (Voc)	21.6 V
Short Circuit Current (Isc)	2 x 6.1 A
Maximum Power Voltage (Vmp)	18 V
Maximum Power Current (Imp)	2 x 5.56 A
Cell Type	Monocrystalline
Operating Temperature	-40°F to +185°F
Folded Size	32.5 x 26.4 x 2.8 in
Net Weight	38.6 lb

Charge Controller Parameters

<b>Electrical Parameters</b>	
Model Rating	20A
Normal Battery Voltage	12V
Maximum Solar Voltage(OCV)	26V
Maximum Battery Voltage	17V
Rated Charging Current	20A
Battery Start Charging Voltage	3V
Electrical Protection and Feature	Spark-free protection. Reverse polarity solar and battery connection Reverse current from battery to solar panel protection at night Over temperature protection with derating charging current Transient overvoltage protection, at the solar input and battery output protects against surge voltage
Grounding	Common Negative
EMC Conformity	FCC Part-15 class B compliant; EN55022:2010;
Self-consumption	< 8mA
<b>Mechanical Parameters</b>	
Dimensions	L6.38 x W3.82 x H1.34 inches
Weight	0.88 lbs.
Mounting	Vertical Wall Mounting
Ingress Protection Rating	IP65
Maximum Terminals Wire Size	10AWG ( 5 mm <sup>2</sup> )
Terminals Screw Torque	13 lbf-in
Operating Temperature	-40 °F to +140 °F
Meter Operating Temperature	-4 °F to +140 °F
Storage Temperature Range	-40 °F to +185 °F
Temp. Comp. Coefficient	-24mV / °C
Temp. Comp. Range	-4°F ~ 122°F
Operating Humidity	100% ( No condensation )



## Battery Charging Parameters

Charging Stages							
Soft-Charge	Output battery voltage is 3V-10VDC, Current = half of the solar panel current						
Bulk	10VDC to 14VDC Current = Rated Charge Current						
Absorption @ 25°C	Constant voltage until current drops to 0.75/1.0 amps and holds for 30s. Minimum 2 hours charging time and maximum 4 hours' time out If charging current < 0.2A, stage will end.						
	Li-ion 12.6V	LiFePO4 14.4V	LTO 14.0V	GEL 14.1V	AGM 14.4V	WET 14.7V	CALCIUM 14.9V
Equalization	Only Wet (Flooded) or Calcium Batteries will equalize, 2 hours maximum Wet (Flooded) = if discharge below 11.5V OR every 28 days charging period. Calcium = every charging cycle						
	Wet (Flooded) 15.5 V				Calcium 15.5 V		
Float	Li-ion N/A	LiFePO4 N/A	LTO N/A	GEL 13.6V	AGM 13.6V	WET 13.6V	CALCIUM 13.6V
Under Voltage Recharging	Li-ion 12.0V	LiFePO4 13.4V	LTO 13.4V	GEL 12.8V	AGM 12.8V	WET 12.8V	CALCIUM 12.8V

## Charging Parameters Glossary

**Equalization Voltage**—equalization voltage is a corrective over-charge of the battery. The user should consult their battery manufacturer regarding specific battery equalization capacity. This parameter sets the equalization voltage to set the battery at when it reaches the equalization state.

**Boost Voltage**—users should check with their battery manufacturer for proper charging parameters. In this stage, users set the boost voltage where the battery will reach a voltage level and remain there until the battery undergoes an absorption stage

**Float Voltage**—once the charge controller recognizes the set float voltage, it will commence floating. The battery is supposed to be fully charged in his state, and the charge current is reduced to maintain battery stability levels.

State of Charge	12 V Battery	Volts per Cell
100%	12.7	2.12
90%	12.5	2.08
80%	12.42	2.07
70%	12.32	2.05
60%	12.20	2.03
50%	12.06	2.01
40%	11.9	1.98
30%	11.75	1.96
20%	11.58	1.93
10%	11.31	1.89
0	10.5	1.75

## Dimensions

### Voyager

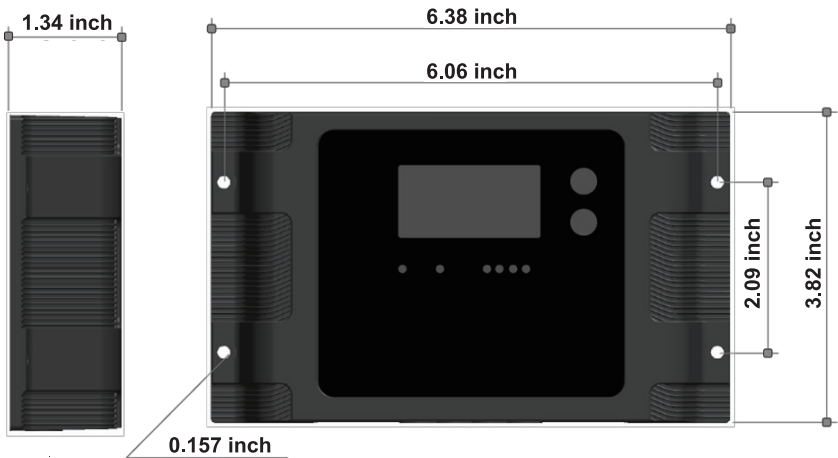

---



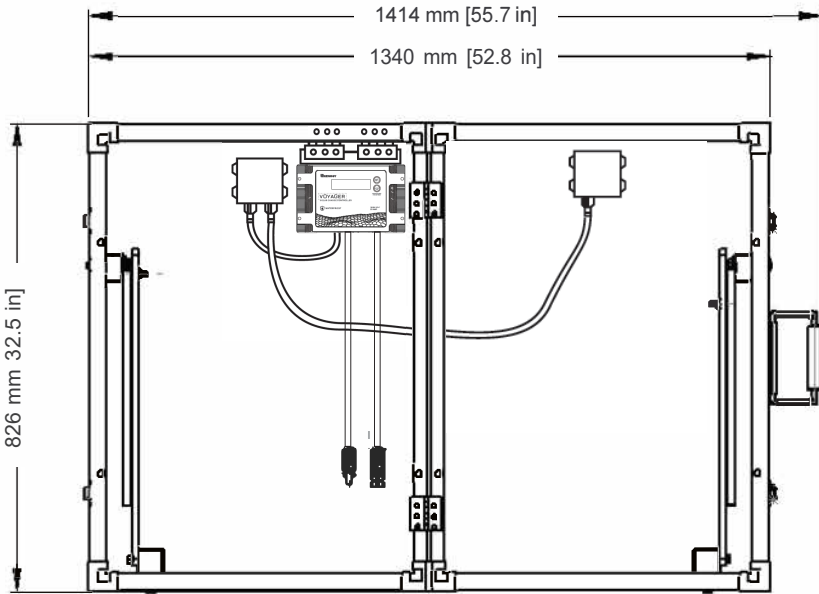

## 200W Suitcase



### Support Brackets Length(s)

Flat Bracket: 21.3 in (540mm), Groove Bracket : 20.3 in (515 mm)

Renogy reserves the right to change the contents of this manual without notice.

**US** |  2775 E Philadelphia St, Ontario, CA 91761, USA  
 909-287-7111  
 [www.renogy.com](http://www.renogy.com)  
 [customerservice@renogy.com](mailto:customerservice@renogy.com)

**CN** |  苏州高新区科技城培源路1号5号楼-4  
 400-6636-695  
 <https://www.renogy.cn>  
 [sales@renogy.cn](mailto:sales@renogy.cn)

**JP** |  <https://www.renogy.jp>  
 [onlinestorejp@renogy.com](mailto:onlinestorejp@renogy.com)

**CA** |  <https://ca.renogy.com>  
 [onlinestoreca@renogy.com](mailto:onlinestoreca@renogy.com)

**AU** |  <https://au.renogy.com>  
 [onlinestoreau@renogy.com](mailto:onlinestoreau@renogy.com)

**UK** |  <https://uk.renogy.com>  
 [onlinestoreuk@renogy.com](mailto:onlinestoreuk@renogy.com)

**DE** |  <https://de.renogy.com>  
 [onlinestorede@renogy.com](mailto:onlinestorede@renogy.com)

**FR** |  <https://fr.renogy.com>  
 [onlinestorefr@renogy.com](mailto:onlinestorefr@renogy.com)