



GAS COOKTOP USER INSTRUCTIONS

THANK YOU for purchasing this high-quality product. Register your cooktop at www.whirlpool.com. In Canada, register your cooktop at www.whirlpool.ca.

For future reference, please make a note of your product model and serial numbers. These can be found on the label located on the bottom of the cooktop.

Model Number _____ Serial Number _____

Table of Contents

KEY USAGE TIPS	3
Propane Gas Conversion	3
Placements of Burner Heads and Caps	3
Lightning the Burners.....	3
Cleaning the Burner: Tips	3
ASSEMBLING YOUR COOKTOPS	4
Assembling the Burners.....	4
Grate Placement	4
COOKTOP FEATURES	5
CARE AND CLEANING	6
ACCESSORIES	6
COOKING WITH YOUR COOKTOP	7
TROUBLESHOOTING	8
WARRANTY	10

Your safety and the safety of others are very important.

We have provided many important safety messages in this manual and on your appliance. Always read and obey all safety messages.



This is the safety alert symbol.

This symbol alerts you to potential hazards that can kill or hurt you and others.

All safety messages will follow the safety alert symbol and either the word "DANGER" or "WARNING."

These words mean:

⚠ DANGER

You can be killed or seriously injured if you don't immediately follow instructions.

⚠ WARNING

You can be killed or seriously injured if you don't follow instructions.

All safety messages will tell you what the potential hazard is, tell you how to reduce the chance of injury, and tell you what can happen if the instructions are not followed.

WARNING: If the information in these instructions is not followed exactly, a fire or explosion may result causing property damage, personal injury or death.

- Do not store or use gasoline or other flammable vapors and liquids in the vicinity of this or any other appliance.
- **WHAT TO DO IF YOU SMELL GAS:**
 - Do not try to light any appliance.
 - Do not touch any electrical switch.
 - Do not use any phone in your building.
 - Immediately call your gas supplier from a neighbor's phone. Follow the gas supplier's instructions.
 - If you cannot reach your gas supplier, call the fire department.
- Installation and service must be performed by a qualified installer, service agency or the gas supplier.

WARNING: Gas leaks cannot always be detected by smell.

Gas suppliers recommend that you use a gas detector approved by UL or CSA.

For more information, contact your gas supplier.

If a gas leak is detected, follow the "What to do if you smell gas" instructions.

State of California Proposition 65 Warnings:

WARNING: This product contains one or more chemicals known to the State of California to cause cancer.

WARNING: This product contains one or more chemicals known to the State of California to cause birth defects or other reproductive harm.

IMPORTANT SAFETY INSTRUCTIONS

WARNING: To reduce the risk of fire, electrical shock, injury to persons, or damage when using the cooktop, follow basic precautions, including the following:

- **WARNING:** NEVER use this appliance as a space heater to heat or warm the room. Doing so may result in carbon monoxide poisoning and overheating of the cooktop.
- **CAUTION:** Do not store items of interest to children in cabinets above the cooktop – children climbing on the cooktop to reach items could be seriously injured.
- Proper Installation – The cooktop, when installed, must be electrically grounded in accordance with local codes or, in the absence of local codes, with the *National Electrical Code, ANSI/NFPA70* or the *Canadian Electrical Code, Part 1*. Be sure the cooktop is properly installed and grounded by a qualified technician.

- This cooktop is equipped with a three-prong grounding plug for your protection against shock hazard and should be plugged directly into a properly grounded receptacle. Do not cut or remove the grounding prong from this plug.
- Disconnect the electrical supply before servicing the cooktop.
- Injuries may result from the misuse of the cooktop such as stepping, leaning, or sitting on the top surface.
- Maintenance – Keep cooktop area clear and free from combustible materials, gasoline, and other flammable vapors and liquids.
- Storage on the cooktop – Flammable materials should not be stored on or near surface units.
- Top burner flame size should be adjusted so it does not extend beyond the edge of the cooking utensil.

SAVE THESE INSTRUCTIONS

KEY USAGE TIPS

Propane Gas Conversion

IMPORTANT: This cooktop is factory set for use with Natural gas. If you wish to use Liquid Propane, call a licensed professional to install the Propane gas conversion kit (included).

Placement of Burner Heads and Caps

All burner caps and burner bases should be properly installed BEFORE operating the cooktop. Check that each burner has the right size head and cap.

Refer to the “Assembling Your Cooktop” section for proper burner head placement details.

Lighting the Burners

IMPORTANT: All burners will click/spark when a knob is pushed in. A burner will light only if the knob is pushed in then turned counterclockwise to IGNITE.

To light the burners:

1. Push in the knob.
2. Turn the knob counterclockwise to IGNITE. Wait until you see a flame.
3. Turn the knob anywhere between Hi and Lo to the desired setting.

Power failure: In case of a power failure, burners can be lit manually. Hold a lit match near the burner and turn the knob counterclockwise to IGNITE.

Cleaning the Burner: Tips

The burners should be kept clean. Spillovers should be cleaned immediately since they can clog the openings in the burners.

IMPORTANT: Before cleaning, make sure all controls are off and the cooktop is cool. For more information, see the “Care and Cleaning” section.

- Remove the burner cap from the base. Clean the burner cap with hot soapy water and then rinse it.
- Remove the burner base and clean the gas tube opening under the base.
- Clean clogged burner ports with a straight pin, needle or small-gauge wire as shown. Do not use a wooden toothpick or clean in the dishwasher.

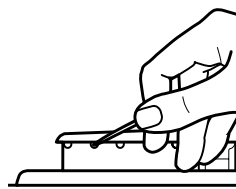

- Gently clean the igniter with a damp cloth.

ASSEMBLING YOUR COOKTOP

Assembling the Burners

Check your model number. Then refer to the following for information specific to your burners.

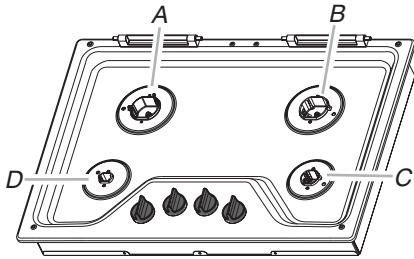

WCG51US0D and WCG75US0D

- A. SpeedHeat™ burner
- B. Standard burner
- C. Standard burner
- D. Accusimmer® burner

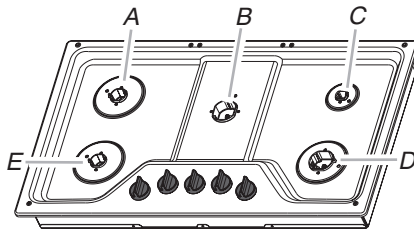

WCG51US6D

- A. Standard burner
- B. SpeedHeat™ burner
- C. Accusimmer® burner
- D. Standard burner
- E. Standard burner

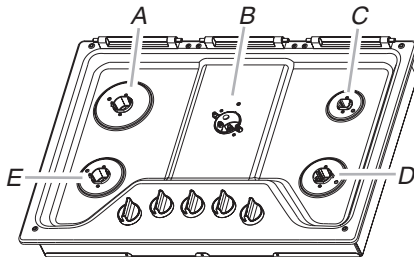

WCG9

- A. Standard burner
- B. FlexHeat™ burner
- C. Accusimmer® Plus burner
- D. Standard burner
- E. Standard burner

- Standard, SpeedHeat™ and FlexHeat™ burners are similar in assembly. Note that there is no hole in the FlexHeat™ dual flame burner head to insert the electrode. The FlexHeat™ burner electrode (C) aligns with the semicircle notch in the head (B).

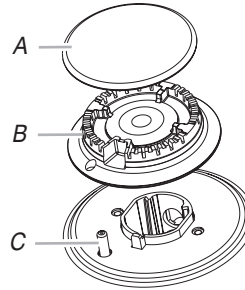

Standard and SpeedHeat™ Burners

- A. Cap
- B. Head
- C. Electrode

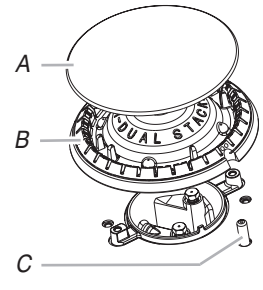

FlexHeat™ Burner

- A. Cap
- B. Head
- C. Electrode

Grate Placement

To install the grates, align the feet on the center grate with the indents on the cooktop. Then install the 2 outer grates by aligning the tabs on the center grate with the slots in the outer grates. Be sure to line up the slots and tabs for proper grate alignment.

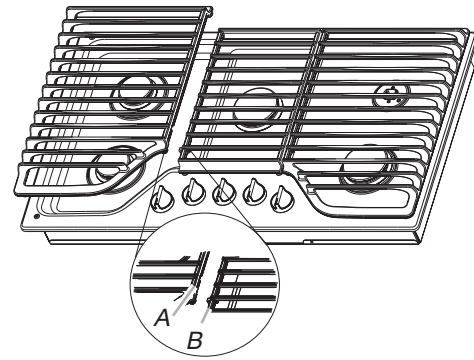

- A. Outer grate slot
- B. Center grate tab

Burner Head Placement

- Burner caps and heads are included with your cooktop.
- Always match the burner head size to the cap size.
- Always line up the hole in the burner head to the electrode.
- The cooktop comes with an extra Melt cap on WCG9 series models. This is a large cap with "MELT" and "FOR SMALLEST BURNER" printed on it. Use this cap over the smallest burner only.

COOKTOP FEATURES

FlexHeat™ Burner

This burner has the flexibility of two burners in one, providing heat ranges from fast boiling to precise simmering.

- **Power:** Select Hi for preparing large quantities of food or to boil liquids quickly. For best results, rotate the knob to Hi in the Power range.
- **Simmer:** Use Simmer to slowly cook foods or to hold a simmer. For best results, rotate the knob to the end of the Simmer range. Only the small flame will light, making this the best burner for simmering or slow cooking.

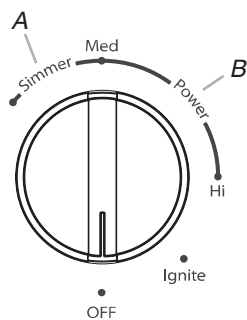

Dual Flame Burner
A. Simmer range
B. Power range

Accusimmer® and Accusimmer® Plus Burners

The Even-Heat™ Simmer burner is for simmering sauces. Position the knob closer to Melt for a more delicate simmer level.

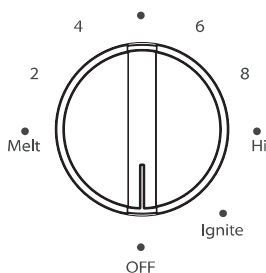

Accusimmer® Plus

NOTE: The melt cap is available on WCG9 series models only.

Melt: For melting chocolate or butter or an even more delicate simmer, the melt cap can be used in place of the standard burner cap on the smallest burner. Set the knob to the "Melt" position.

Remove the small burner cap and replace it with the larger Melt cap for delicate simmering. For less delicate simmering, use the small cap.

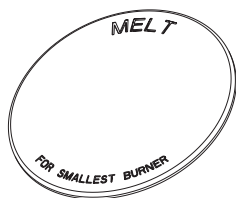

EZ-2-Lift™ Hinged Cast Iron Grates

Your cooktop comes with hinged grates for easier cleaning. The grates pivot upward and toward the back of the cooktop for easy access under the grates.

The grates will stop once they are moved to their vertical (fully open) position. A 20" (50.8 cm) minimum clearance from the countertop to the bottom of the upper cabinets/appliances is needed to fully open the grates.

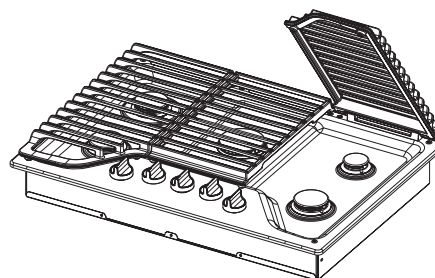

Be sure to return the grates to their normal (down) position once cleaning is complete.

The grates are removable for cleaning.

To attach the grates to their hinges, insert the grate slot over the hinge pin on the back of the cooktop. Be sure to keep the grate angled above the cooktop to avoid scratching the cooktop until the grate is seated on the hinge pin. Then position the grate down onto the cooktop.

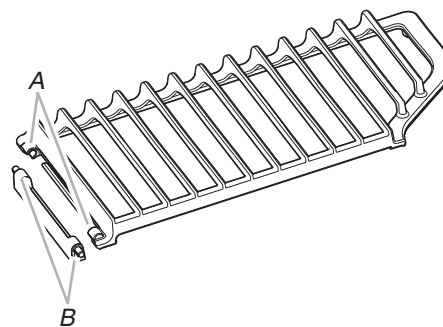

A. Grate slot
B. Hinge pin

SpeedHeat™ Burner

Use the SpeedHeat™ burner for rapid boiling, searing and frying. The SpeedHeat™ burner is the left rear burner on 30" (76.2 cm) models and the center burner on 36" (91.4 cm) models.

CARE AND CLEANING

IMPORTANT: Before cleaning, make sure all controls are off and the cooktop is cool. Soap, water and a soft cloth or sponge are suggested first unless otherwise noted. Food spills containing acids, such as vinegar and tomato, should be cleaned as soon the cooktop is cool. These spills may affect the finish.

Surface Type	Cleaning Recommendation
Control Knobs (Plastic)	The knobs should be cleaned with soap and water or in the dishwasher. To remove the knobs, be sure the knobs are in the OFF position. Do not remove the seals under the knobs.
Burner Grates	Soap and Water: Use a nonabrasive plastic scrubbing pad and mildly abrasive cleanser, soap and water. Dishwasher: The grates may be cleaned in the dishwasher. Remove any burnt on food prior to placing the grates in the lowest rack in the dishwasher. To avoid chipping, do not bang grates against each other or hard surfaces, such as cast iron cookware. Although the grates are durable, they will gradually lose their shine due to exposure to high temperatures.
Burner Caps	Use a nonabrasive plastic scrubbing pad and mildly abrasive cleanser, soap and water. Do not place caps in the dishwasher or reassemble caps on burners when wet.
Burner Base	The holes in the burner bases must be kept clean for proper ignition and a complete, even flame. Refer to “Cleaning the Burners: Tips” in the “Key Usage” section.
Porcelain Enamel Cooktop Surface	Use a nonabrasive scrubbing pad and glass cleanser or a mild liquid cleaner, such as affresh® Kitchen and Appliance Cleaner, Part Number W10355010.
Stainless Steel Cooktop Surface	For best results, use a soft cloth or non-scratch sponge. Rub in direction of the grain to avoid damaging the surface. Use all-purpose cleaner, such as affresh® Kitchen and Appliance Cleaner, Part Number W10355010. For stainless steel finishes, order affresh® Stainless Steel Cleaner, Part Number W10355016. Do not use scouring pads, abrasive cleaners, cooktop cleaner, steel wool pads, gritty washcloths or abrasive paper towels. To order affresh® cleaners, call the Whirlpool Customer eXperience center at 1-800-442-9991 or visit www.whirlpool.com and click on “Service and Support” and then “Replacement Parts.” In Canada, call 1-800-807-6777 or visit www.whirlpool.ca .

ACCESSORIES

Enhance your new cooktop with the following genuine Whirlpool accessories. For more information on options and ordering, call **1-800-442-9991**, or visit us at: **www.whirlpool.com/accessories**. In Canada, call **1-800-807-6777** or visit us at **www.whirlpoolparts.ca**.

Gourmet Griddle (optional accessory)

A griddle accessory is available for these cooktops. The griddle provides a large surface for cooking meats, pancakes, sandwiches, etc. It is designed to match the right grate of your cooktop without interfering with the controls. Order Part Number W10685483.

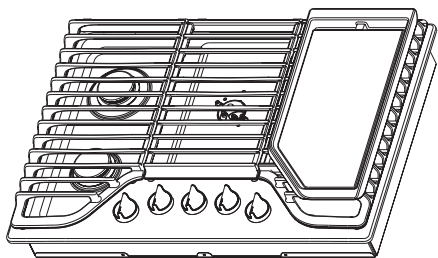

White Ice and Black Ice Collection

To complete the look of your White Ice or Black Ice Whirlpool kitchen appliances, coordinating knobs can be ordered. Gray grates are also

Stainless steel color knobs: order Part Number W10698166.

Gray grates: order Part Number W10594440 for model number WCG51US0DW or Part Number W10594443 for model number WCG51US6DW.

COOKING WITH YOUR COOKTOP

⚠️ WARNING



Fire Hazard

Do not let the burner flame extend beyond the edge of the pan.

Turn off all controls when not cooking.

Failure to follow these instructions can result in death or fire.

Selecting the proper flame size

The flame size should match the cookware you are using. When you adjust the heat, watch the flame, not the knob. A flame larger than the bottom of the cookware wastes energy and will heat the handle.

- **High flame** - Start food cooking, bring water to a boil, or pan broiling.
- **Medium flame** - Maintain a slow boil, fry or sauté, thicken sauces, steam, or stew.
- **Low flame** - Keep food cooking, simmer, or keep food warm.

REMEMBER: When cooktop is in use, the entire cooktop area may become hot.

Cookware

Ideal cookware should have a flat bottom, straight sides and a well-fitting lid. The material should be medium to heavy thickness. Rough finishes may scratch the cooktop. Aluminum and copper cookware may be used but may leave permanent marks on the grates or cooktop. Use the chart below as a guide for cookware material.

IMPORTANT: Do not leave empty cookware on a hot surface cooking area or burner.

Canning

When canning for long periods, alternate the use of burners between batches to allow time for the most recently used area to cool.

- Center the canner on the grate.
- Do not place the canner on 2 burners at the same time.

For more information, contact your local agricultural department or a company that manufactures home canning products.

Cookware	Characteristics
Aluminum	Heats quickly and evenly. Medium or heavy thickness is best for most cooking tasks.
Cast iron	Heats slowly and evenly. Good for browning and frying. Maintains heat for slow cooking.
Ceramic or ceramic glass	Follow manufacturer's instructions. Heats slowly and evenly. Ideal results on low to medium heat.
Copper	Heats very quickly and evenly.
Earthenware	Follow manufacturer's instructions. Use on low heat.
Porcelain enamel-on-steel or cast iron	Refer to stainless steel or cast iron.
Stainless steel	Heats quickly but unevenly. A core or base of aluminum or copper on stainless provides even heating.

TROUBLESHOOTING

First try the solutions suggested here. If you need further assistance or more recommendations that may help you avoid a service call, refer to the warranty page in this manual or visit www.whirlpool.com/product_help for recommendations that may help you avoid a service call. In Canada, visit <http://www.whirlpool.ca>.

Contact us by mail with any questions or concerns at the address below:

In the U.S.A.:

Whirlpool Brand Home Appliances
Customer eXperience Center
553 Benson Road
Benton Harbor, MI 49022-2692

In Canada:

Whirlpool Brand Home Appliances
Customer eXperience Centre
200 - 6750 Century Ave.
Mississauga, Ontario L5N 0B7

Please include a daytime phone number in your correspondence.

⚠ WARNING



Electrical Shock Hazard

Plug into a grounded 3 prong outlet.

Do not remove ground prong.

Do not use an adapter.

Do not use an extension cord.

Failure to follow these instructions can result in death, fire, or electrical shock.

PROBLEM	POSSIBLE CAUSES AND/OR SOLUTIONS
Nothing will operate	<p>Check the following:</p> <ul style="list-style-type: none"> ■ Make sure the power supply cord is plugged into a grounded 3 prong outlet. ■ Replace the fuse or reset the circuit breaker. If the problem continues, call an electrician. ■ Make sure the cooktop is properly connected to the gas supply. Contact a service technician or refer to the installation instructions.
Burners will not operate	<p>If this is the first time the cooktop is being used, turn on any one of the burner knobs to release air from the gas lines. Be sure the control knob is pushed in before turning to a setting.</p> <p>A burner port (hole) may be clogged or the igniter may need cleaning. Refer to “Cleaning the Burner: Tips” in the “Key Usage Tips” section.</p> <p>Check that the burner base and caps are positioned correctly. Refer to “Placement of Burner Heads and Caps” in the “Key Usage Tips” section.</p>
Burner flames are uneven, yellow and/or noisy	<div style="display: flex; align-items: center;"> <div style="flex: 1;"> <p>Compare the flame to the illustrations below. If the flames look like A, call or service. Normal flames look like B or C. If Propane gas is being used, the cooktop may have been converted improperly. Contact a service technician or refer to the “Assistance or Service” section in the Use and Care Guide.</p> <p>A burner port (hole) may be clogged. Refer to “Cleaning the Burner: Tips” in the “Key Usage Tips” section.</p> <p>Check that the burner caps are positioned correctly. Refer to “Placement of Burner Heads and Caps” in the “Key Usage Tips” section.</p> </div> <div style="flex: 2; text-align: center;">  <div style="display: flex; justify-content: space-around; font-size: small;"> <div style="text-align: center;"> <p>Yellow Flames <i>Call for Service</i></p> </div> <div style="text-align: center;"> <p>Yellow Tips on Outer Cones <i>Normal for Propane Gas</i></p> </div> <div style="text-align: center;"> <p>Soft Blue Flames <i>Normal for Natural Gas</i></p> </div> </div> </div> </div>
When a knob is pushed, all burners spark	<p>Sparking/clicking of all the burners is normal operation. A burner will light only if the knob is pushed in and turned to the 🔥 position.</p>
Burner is making a popping noise	<p>If the burner is wet or dirty, clean and/or let the burner dry.</p>



PROBLEM	POSSIBLE CAUSES AND/OR SOLUTIONS
Excessive heat around the cookware on cooktop	Be sure the cookware is approximately the same size as the cooking area and surface burner. Cookware should not extend more than ½" (13 mm) outside the cooking area. Adjust the flame so that it does not wrap around the cookware.
Cooking results are not what expected	Check the following: <ul style="list-style-type: none"> ■ Be sure the proper cookware is being used. Refer to the "Cooking with Your Cooktop" section. ■ Check the heat level. Refer to "Excessive heat around the cookware on cooktop." ■ Check the level of the cooktop. Refer to the Installation Instructions.
Flame too High or too Low	Ensure the cooktop gas supply is correct (Propane or Natural gas). These cooktops come from the factory set for Natural gas. Refer to the Installation Instructions to verify that the pressure regulator is installed correctly and the line pressure and the gas line pressure are correct.



WHIRLPOOL® MAJOR APPLIANCE LIMITED WARRANTY

ATTACH YOUR RECEIPT HERE. PROOF OF PURCHASE IS REQUIRED TO OBTAIN WARRANTY SERVICE.

Please have the following information available when you call the Customer eXperience Center:

- Name, address and telephone number
- Model number and serial number
- A clear, detailed description of the problem
- Proof of purchase including dealer or retailer name and address

IF YOU NEED SERVICE:

1. Before contacting us to arrange service, please determine whether your product requires repair. Some questions can be addressed without service. Please take a few minutes to review the Troubleshooting or Problem Solver section of the Use and Care Guide or visit www.whirlpool.com/product_help.
2. All warranty service is provided exclusively by our authorized Whirlpool Service Providers. In the U.S. and Canada, direct all requests for warranty service to:

Whirlpool Customer eXperience Center

In the U.S.A., call 1-800-253-1301. In Canada, call 1-800-807-6777.

If outside the 50 United States or Canada, contact your authorized Whirlpool dealer to determine whether another warranty applies.

ONE YEAR LIMITED WARRANTY

WHAT IS COVERED

For one year from the date of purchase, when this major appliance is installed, operated and maintained according to instructions attached to or furnished with the product, Whirlpool Corporation or Whirlpool Canada LP (hereafter "Whirlpool") will pay for Factory Specified Replacement Parts and repair labor to correct defects in materials or workmanship that existed when this major appliance was purchased, or at its sole discretion replace the product. In the event of product replacement, your appliance will be warranted for the remaining term of the original unit's warranty period.

YOUR SOLE AND EXCLUSIVE REMEDY UNDER THIS LIMITED WARRANTY SHALL BE PRODUCT REPAIR AS PROVIDED HEREIN. Service must be provided by a Whirlpool designated service company. This limited warranty is valid only in the United States or Canada and applies only when the major appliance is used in the country in which it was purchased. This limited warranty is effective from the date of original consumer purchase. Proof of original purchase date is required to obtain service under this limited warranty.

WHAT IS NOT COVERED

1. Commercial, non-residential, multiple-family use, or use inconsistent with published user, operator or installation instructions.
2. In-home instruction on how to use your product.
3. Service to correct improper product maintenance or installation, installation not in accordance with electrical or plumbing codes or correction of household electrical or plumbing (i.e. house wiring, fuses or water inlet hoses).
4. Consumable parts (i.e. light bulbs, batteries, air or water filters, preservation solutions, etc.).
5. Defects or damage caused by the use of non-genuine Whirlpool parts or accessories.
6. Conversion of products from natural gas or Propane gas.
7. Damage from accident, misuse, abuse, fire, floods, acts of God or use with products not approved by Whirlpool.
8. Repairs to parts or systems to correct product damage or defects caused by unauthorized service, alteration or modification of the appliance.
9. Cosmetic damage including scratches, dents, chips, and other damage to the appliance finishes unless such damage results from defects in materials and workmanship and is reported to Whirlpool within 30 days.
10. Discoloration, rust or oxidation of surfaces resulting from caustic or corrosive environments including but not limited to high salt concentrations, high moisture or humidity or exposure to chemicals.
11. Food or medicine loss due to product failure.
12. Pick-up or delivery. This product is intended for in-home repair.
13. Travel or transportation expenses for service in remote locations where an authorized Whirlpool servicer is not available.
14. Removal or reinstallation of inaccessible appliances or built-in fixtures (i.e. trim, decorative panels, flooring, cabinetry, islands, countertops, drywall, etc.) that interfere with servicing, removal or replacement of the product.
15. Service or parts for appliances with original model/serial numbers removed, altered or not easily determined.

The cost of repair or replacement under these excluded circumstances shall be borne by the customer.

DISCLAIMER OF IMPLIED WARRANTIES

IMPLIED WARRANTIES, INCLUDING ANY IMPLIED WARRANTY OF MERCHANTABILITY OR IMPLIED WARRANTY OF FITNESS FOR A PARTICULAR PURPOSE, ARE LIMITED TO ONE YEAR OR THE SHORTEST PERIOD ALLOWED BY LAW. Some states and provinces do not allow limitations on the duration of implied warranties of merchantability or fitness, so this limitation may not apply to you. This warranty gives you specific legal rights, and you also may have other rights that vary from state to state or province to province.

DISCLAIMER OF REPRESENTATIONS OUTSIDE OF WARRANTY

Whirlpool makes no representations about the quality, durability, or need for service or repair of this major appliance other than the representations contained in this warranty. If you want a longer or more comprehensive warranty than the limited warranty that comes with this major appliance, you should ask Whirlpool or your retailer about buying an extended warranty.

LIMITATION OF REMEDIES; EXCLUSION OF INCIDENTAL AND CONSEQUENTIAL DAMAGES

YOUR SOLE AND EXCLUSIVE REMEDY UNDER THIS LIMITED WARRANTY SHALL BE PRODUCT REPAIR AS PROVIDED HEREIN. WHIRLPOOL SHALL NOT BE LIABLE FOR INCIDENTAL OR CONSEQUENTIAL DAMAGES. Some states and provinces do not allow the exclusion or limitation of incidental or consequential damages, so these limitations and exclusions may not apply to you. This warranty gives you specific legal rights, and you also may have other rights that vary from state to state or province to province.

