Radioddity

UB15-G Manual

1. Overview

- ✧ The UB15-G is a GMRS analog mobile transceiver.
- ✧ It includes a main radio unit, a handheld microphone, and a mounting bracket.

2. Product Features

- ✧ LCD display with 7 selectable backlight colors
- ✧ LCD backlight brightness adjustable
- ✧ Channel naming function
- ✧ TX/RX indicator LED
- ✧ Frequency Range: TX: GMRS; RX: 400–470MHz
- ✧ 80 Programmable channels (22 of which are GMRS fixed channels, the remaining channels are editable for frequency.)
- ✧ CALL TONE
- ✧ Keyboard lock function
- ✧ NOAA Weather (NOAA)
- ✧ Dual Watch
- ✧ High/Low power selection
- ✧ Wide/Narrow bandwidth selection
- ✧ Priority Channel (PRI)
- ✧ Priority Channel Watch
- ✧ Scan
- ✧ Monitor (MONI)
- ✧ Squelch (SQL)
- ✧ Transmit Timeout Timer 180S (TOT)
- ✧ CTCSS/DCS
- ✧ Noise Reduction (NRC)
- ✧ TX Noise Cancellation (ANC)
- ✧ Key Beep
- ✧ Transmit End Tone (ROGER BEEP)
- ✧ VOX (9 levels)
- ✧ Mic Gain (3 levels)
- ✧ Voice Record Playback

3. Technical Specifications

GENERAL	
Frequency Range	TX:GMRS Band RX:400–470MHz
Channel Spacing	12.5KHz/25KHz
Channel Capacity	22 channels+8 Repeater channels+50 Programmable channels(Support GMRS Frequency only)
Frequency Stability	±300Hz
Operating Temperature	-30℃~+60℃
Operating Voltage	13.8V

Size	135*110*25
TRANSMITTER	
Power Output	High: 15W/ Low: 5W
Emission current	High: 5A/Low: 1A
Modulation Limiting	Narrow: $\cong 2.5\text{KHz}$ /Wide: $\cong 5.0\text{KHz}$
Adjacent Channel Power	Narrow: $\cong 60\text{dB}$ /Wide: $\cong 65\text{dB}$
Hum& Noise	$\cong 40\text{dB}$
Audio Distortion	$\cong 5\%$
Mic Sensitivity(@L2)	5-10mV
Antenna port hum	9KHz-1GHz: $\cong -50\text{dBc}$ 1GHz-12.75GHz $\cong -55\text{dBc}$
RECEIVER	
Sensitivity	$\cong -119\text{dBm@SINAD}=12\text{dB}$
Audio Distortion	$\cong 5\%$
Hum& Noise	$\cong 45\text{dB@}25\text{KHz}/\cong 40\text{dB@}12.5\text{KHz}$
Adjacent Channel Selectivity	$\cong 60\text{dB@}12.5\text{KHz}/\cong 60\text{dB@}25\text{KHz}$
Inter Modulation	$\cong 60\text{dB}$
Blocking or Desensitization	$\cong 84\text{dB}$
Co-Channel Rejection	$\cong -12\text{dB}$
Max Audio Output@1KHz 8 Ω	$\cong 1\text{W}$
Standby Current	$\cong 360\text{mA}$

4. Structural Appearance

✧ Microphone

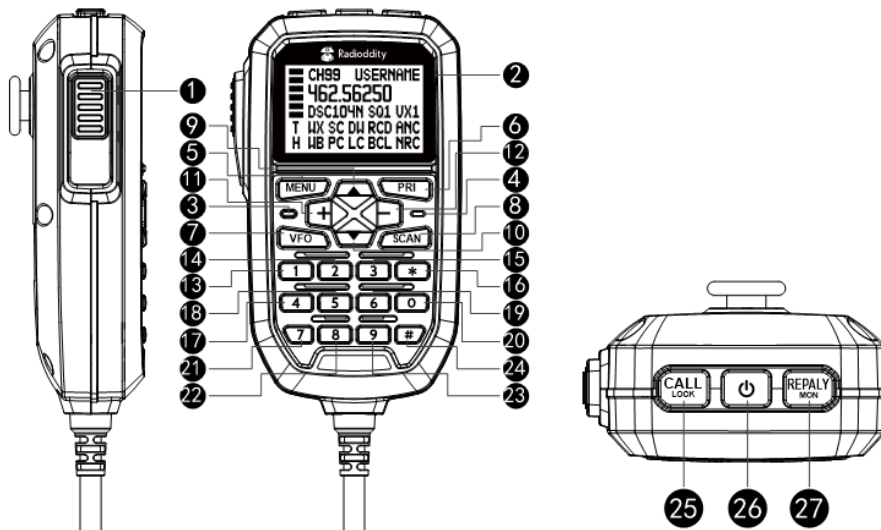

NO	Name	Short Press	Long Press
1	PTT	Transmit/Save settings and return to main screen	
2	LCD		
3	LED	TX/RX Indicator	
4	MIC		
5	MENU	Enter Menu Mode Enter Menu Options Confirm changes and return to previous menu	VFO Channel Store
6	PRI	Recall Pri Channel	Priority Channel Setup
7	VFO	Enter/Exit VFO Mode	Delete Channel
8	Scan	Start / Stop Scan	Add channel to / Remove channel from scan list
9	▽ CH-	Channel -	Channel Continuous -
10	△ CH+	Channel +	Channel Continuous +
11	+	Volume +	Volume Continuous +
12	-	Volume -	Volume Continuous -
13	1	Digit 1	
14	2	Digit 2	
15	3	Digit 3	
16	*	Back Key	Enter/Exit Weather Mode
17	4	Digit 4	
18	5	Digit 5	
19	6	Digit 6	

20	0	Digit 0	Start / Finish Channel Name Edit
21	7	Digit 7	
22	8	Digit 8	
23	9	Digit 9	
24	#	VFO Frequency Confirm Key	Turn On / Turn Off Dual Watch
25	CALL/LOCK	Transmit CALL TONE	Keyboard Lock / Unlock
26	Power button		Power On / Off
27	REPLAY/MON	Voice Record Playback	Monitor On / Off

5. LCD Display Indicators

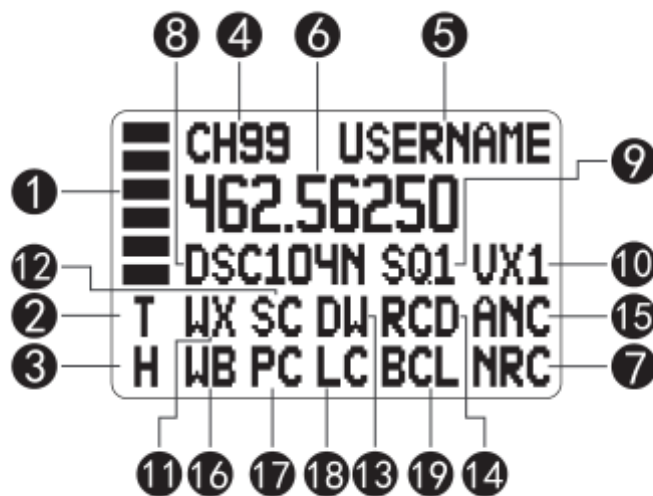

NO	Symbol	Description		NO	Symbol	Description	
1		Transmit/Receive Strength Indicator		11	WX	Weather Forecast Indicator	
2	T	T	TX Indicator	12	SC	Not Blinking	Scan List Indicator
		R	RX Indicator			Blinking	Scanning
		M	Monitor Indicator				
3	H	H	High Power Indicator	13	DW	Dual Watch	
		L	Low Power Indicator				
4	CH99	Channel No.		14	RCD	Record On	
5	USERNAME	Channel Name		15	ANC	TX Noise Reduction On	
6	462.5625	Channel Frequency		16	WB	NB	Narrow Band
						WB	Wide Band
7	NRC	RX Noise Reduction On		17	PC	Priority Channel Indicator	
8	DCS104	CTC/DCS Indicator		18	LC	Keyboard Lock Indicator	
9	SQ1	SQ Level Indicator		19	BCL	Busy Lock	
					VOL 01	While Adjusting Volume	
10	VX1	VOX Level Indicator					

6. Function Introduction

6.1 Power on/off

Power on the radio by long-pressing the power button when it is off.

Press and hold the power button for 2 seconds to turn off the radio when it is on.

High voltage alarm: If the supply voltage exceeds 16V, the radio will emit a high-voltage alert tone, display “DCH” on the LCD, and disable transmission.

Low voltage alarm: If the supply voltage drops below 10V, the radio will emit a low-voltage alert tone and display “DCL” on the LCD.

Low voltage auto power-off: If the supply voltage drops below 9V, the radio will power off automatically.

6.2 Channel Selection

Users can select the current working channel using the Δ/∇ buttons on the hand microphone, or directly enter the channel number via the numeric keypad and press the # key to quickly switch channels.(Example: Enter 05 and press #, the radio will switch to Channel 5.)

6.3 Volume Adjustment

Users can increase or decrease the radio's receive volume using the VOL+ / VOL- buttons on the hand

microphone. The unit supports a total of 10 volume levels from 0 to 9.

6.4 Transmit & Receive

To communicate between two radios, both must be set to the same frequency and CTC/DCS code.

To make a call, press and hold the PTT button on the microphone and speak into it in a normal voice.

Note: For best clarity, hold the microphone 2 to 3 inches from your mouth while speaking.

The T icon will appear continuously on the LCD during transmission. The R icon will appear continuously on the LCD during reception.

6.5 Squelch Level Adjustment

Users can adjust the squelch sensitivity level via the menu. This radio provides 10 squelch levels (0 - 9).

- 0 - Squelch open
- 1 - Maximum sensitivity (minimum squelch)
- 5 - Medium sensitivity (medium squelch)
- 9 - Minimum sensitivity (maximum squelch)

6.6 CTCSS/DCS Settings

Users can set the sub-audible tones of the radio via the menu. This radio provides 38 groups of analog tones (CTCSS) and 208 groups of digital tones (104 groups of DCSN + 104 groups of DCSI). Refer to the bottom of this manual for the sub-audible tone frequency list.

6.7 Power Level Setting

The radio offers two power levels, **high** and **low**, for users to choose from. Users can select different power levels according to different scenarios.

Note: Channels 1 - 7 are set to low power by default and cannot be changed.

6.8 Priority Channel - Set / Recall / Watch

To allow users to quickly switch to frequently used channels, this radio provides priority channel setting and recall functions.

Setting: Users can switch to a frequently used channel using the channel keys, then long-press the **PRI** button to set it as the priority channel. The PC icon will appear above the channel display.

Recall: During operation, short-press the **PRI** button to toggle between the current channel and the priority channel.

Watch Function: When the Pri Watch function is enabled, the radio will scan the priority channel intermittently during scanning (every 1 seconds).

Dual Watch: The Dual Watch function continuously monitors both the current channel and the priority channel.

Long-press the # key to enable Dual Watch; the **DW** icon will appear.

Long-press the # key again to disable Dual Watch; the **DW** icon will disappear.

6.9 Scan Function

Adding & Removing from Scan List

Users can add the current channel to the scan list or remove it by long-pressing the Scan button. When the channel is in the scan list, the **SC** icon will appear on the LCD.

This radio provides three scan modes for selection: SE / CO / TO.

SE: In this mode, scanning stops automatically when a signal is detected and stays on that channel. To resume scanning, you must restart it manually.

CO: In this mode, scanning pauses on the channel when a signal is detected. If the signal disappears, the radio resumes scanning after 5 seconds.

TO: In this mode, scanning pauses on the channel when a signal is detected. The radio automatically resumes scanning after 5 seconds, regardless of the signal.

In addition, if PTT is pressed during scanning, the radio will transmit on the currently detected channel. After releasing PTT, the radio stays on that channel for 10 seconds, then resumes scanning.

6.10 VOX (Voice-Operated Transmit)

This radio features a VOX (voice-activated) function for user convenience. When enabled, speaking directly into the microphone will automatically trigger transmission.

The function has 9 sensitivity levels. The higher the level, the louder the voice required to activate VOX transmission.

Recommendation: Enable the ANC function at the same time as VOX to prevent VOX from being triggered by ambient noise.

6.11 RX Noise Reduction (NRC)/ TX Noise Reduction (ANC)

NRC: When this function is enabled, the radio will greatly reduce (but not completely eliminate) non-voice noise from the transmitted signal during reception, improving the user experience.

ANC: When this function is enabled, ambient noise will be filtered out, and only human voice will be transmitted.

6.12 Busy Channel Lockout (Busy Lock)

When this function is enabled, pressing PTT while the radio is receiving will not trigger transmission. The radio will emit a continuous transmit-prohibit tone until the PTT button is released.

6.13 Transmit Timeout Timer (TOT)

When the transmit time-out function is enabled and a time is set, the radio will stop transmitting once the set duration is reached after you press and hold PTT. To continue transmitting, release PTT and press it again.

6.14 Microphone Gain Adjustment

Users can adjust the microphone sensitivity via the menu. This radio offers 3 sensitivity levels (L1 / L2 / L3). The higher the level, the more sensitive the microphone.

6.15 NOAA Weather Radio (Scan / Monitor / Alert)

The UB15-G is equipped with Weather Receive and Weather Alert functions, which can directly obtain information about severe weather events or domestic emergencies from the National Weather Service (NWS) of the United States, allowing you to take appropriate actions to ensure safety.

WX Band Channels

Channel Number	Frequency (MHz)
1	162.550
2	162.400
3	162.475
4	162.425
5	162.450
6	162.500
7	162.525
8	161.650
9	161.775
10	163.275

Weather Scan

Long press the * key for 2 seconds to enter Weather Mode. The radio will automatically scan active weather channels, with the WX icon blinking. Scanning stops and switches to receive mode when a signal is detected. Press the channel key to resume scanning.

Long press the * key again for 2 seconds to exit Weather Mode; the WX icon will disappear.

Weather Monitor

In Weather Scan mode, short press the SCAN key to stop scanning and enter monitor mode. To resume scanning in Weather Monitor mode, short press SCAN again.

Weather Alert

In Weather Monitor mode, use the channel keys to select your desired weather alert channel, then short press MENU to enter the Weather Alert on/off setting. Use the channel keys to select ON or OFF.

When Weather Alert is ON:

In Weather Mode, a weather alert tone (1050Hz) on any channel will trigger the alert.

In radio channel mode, the WX icon continues blinking, and the radio monitors the last used weather channel.

When a weather alert is triggered, press any key to acknowledge the alert, and the radio will enter Weather Receive mode. If the radio remains in Weather Mode and continues receiving weather alert signals, the alert will sound again after 20 seconds.

6.16 Frequency Mode (VFO)

Users can manually set the radio's channel frequency using this function. The frequency setting range is 400 – 470 MHz.

Note: Transmission is allowed only on GMRS frequencies and GMRS repeater frequencies. All other frequencies are for reception only.

How to Edit Frequency

Short press the VFO button to enter VFO mode. You may then:

Enter the frequency directly using the numeric keypad, or

Adjust by preset frequency steps using the channel up/down keys.

After entering the frequency, short press the # key to confirm.

How to Adjust Frequency Step

Short press MENU to enter menu mode. Use channel up/down keys to select the Step menu. Press MENU again to enter step setting. Use channel up/down keys to select your desired step value, then press * to confirm.

Available steps: 2.5 kHz / 5.0 kHz / 6.25 kHz / 12.5 kHz / 25 kHz / 50 kHz / 100 kHz

Factory default: 12.5 kHz

Storing Custom Channels

After setting your custom frequency, long press MENU to enter save mode. The default channel (flashing) is the nearest empty channel. Use the up/down keys to select your desired storage channel. Long press MENU again to save the channel and exit.

If the selected channel already contains data, the radio will prompt: “Overwrite CH? ”

Press MENU to overwrite the existing channel.

Press * or PTT to cancel.

Notes:

If the stored custom frequency matches GMRS channels 1 – 7, high power is not allowed on that channel.

If the stored custom frequency matches GMRS channels 8 – 14, transmission is not allowed on that channel.

Deleting Custom Channels

From the channel interface, select the channel to delete using the channel keys. Long press VFO to delete the channel.

The radio will prompt: “Delete CH? ”

Press MENU to confirm deletion.

Press * or PTT to cancel and keep the channel.

Note: Only custom-edited channels can be deleted. GMRS channels and repeater channels cannot be deleted. An error tone will sound if deletion is attempted on GMRS or repeater channels.

6.17 Repeater Channels

Repeater channels are used to communicate with a repeater, allowing it to retransmit your signal. Repeater channels extend the radio communication range and overcome shielding caused by solid obstacles. In conventional direct mode, your radio transmits and receives on a single fixed frequency.

Reception will be weak if obstacles block the signal, as hills, tall buildings, metal structures and similar

objects often create shielding between radios. When using a repeater channel, the signal from your radio is received by the repeater and retransmitted on a different frequency simultaneously, enabling much longer-distance communication.

Enabling and Disabling Repeater Channels

Users can enable or disable repeater channels via the **Repeater** menu. When repeater channels are enabled, 8 additional repeater channels are added to the original channel list as shown below:

Channels before enabling repeater function: CH01 - CH02 - CH03 - ... - CH15 - CH16 - CH17 - ... - CH22

Channels after enabling repeater function: CH01 - CH02 - CH03 - ... - CH15 - CH15RP - CH16 - CH16RP - CH17 - CH17RP - ... - CH22 - CH22RP

6.18 Reset (Restore Factory Settings)

Users can reset the radio via the Reset menu. After entering this menu, select Yes to restore the radio to its factory default settings, or select No to cancel and exit the reset menu.

The factory settings after reset are as follows:

Channel	GMRS 01	CTC/DCS	OFF
SQ	1	NRC Level	OFF
Scan List	All Channels	VOX	OFF
Key Beep	ON	VOX Level	L1
Roger Beep	ON	Backlight Color	White
Backlight Brightness	L2	RX Noise Reduction (NRC)	OFF
Busy Channel Lockout	OFF	TX Noise Reduction (ANC)	OFF
Backlight Timeout	30S	Priority Channel	02
Mic Gain	L2	Priority Watch (Pri Watch)	On

6.19 Channel Name Edit Function

Users can edit the channel name via the radio's keypad or programming software. The channel name supports a maximum of 8 characters, and each character can be selected from 0 - 9 and A - Z.

How to Set Channel Name via Radio Keypad

The default channel name is: USERNAME

Long press the 0 key to enter channel name editing mode. The first character "U" will start flashing. Users can edit this position using the Δ CH+ / ∇ CH- keys (0 - 9, A - Z).

After editing the first character, use the + / - keys to move the cursor to the previous or next position for further editing.

Once you have finished editing the desired channel name, long press the 0 key again to save and complete the setup.

6.20 Voice Recording & Playback

The radio can automatically store up to 20 recordings, each up to 1 minute in length.

The recording function will automatically record received audio in the following modes:

CB receive channels

Scan mode

Note: Recording does not occur in monitor mode or when squelch is set to SQ=0.

Short press the **REPLAY** button to play the most recent received message by default.

During playback, the display shows **RPY** and the current recording number. Users can use the Δ CH+ / ∇ CH - keys to switch between recordings for playback.

After playback finishes, a long confirmation tone will sound, and the radio will return to channel mode.

The recording function can be enabled or disabled via the menu.

Notes:

Maximum number of recordings: 20.

Audio shorter than 500 ms will not be recorded.

The radio stops receiving signals during playback.

New recordings automatically overwrite the oldest ones when memory is full.

Transmit (TX) audio is not recorded.

6.21 Main Unit + Hand Mic Dual Speaker Mode

This radio is equipped with one speaker on both the main unit and the hand mic. Users can set their preferred speaker operating mode via the menu.

7. Menu Description

Main Menu	Submenu	Option	Description
Scan	Scan/Skip		Scan: channel included in scan list. Skip: channel excluded from scan list.
Scan mode	Se、Co、To		Default: Co
CTCSS/DCS	OFF/CTC/DCS	38 CTCSS / 208 DCS	Sets sub-audio signaling.
TX POWER	Hi/Lo		Power for channels 1 - 7 is fixed and non-adjustable.
VOX	OFF/L1/L2/L3/ L4/L5/L6/L7/L 8/L9		
NRC	ON/OFF		ON: NRC Enabled OFF: NRC Disabled
ANC	ON/OFF		ON: ARC Enabled OFF: ARC Disabled
Bandwidth	Narrow/Wide		Select wideband or narrowband.

Backlight	OFF/L1/L2/L3		LCD backlight brightness level.
Backlight Color	White / Blue / Green / Red / Cyan / Purple / Yellow		LCD backlight color selection.
Backlight Time	Always/10s/20s/30s		Backlight timeout duration.
Key Beep	ON/OFF		Enables or disables keypad tone.
Replay	ON/OFF		Default: ON
SQL	0-9		Squelch level adjustment.
TOT	OFF/60S/120S/180S		OFF: No Time-out Timer 60S / 120S / 180S
Call Tone	01-10		Default: 01
PRI WATCH	ON/OFF		ON: Scans the priority channel every 1.5 seconds after scanning starts OFF: Does not scan the priority channel
Repeater	ON/OFF		ON: Repeater Channel Enabled OFF: Repeater Channel Disabled
Speaker	Dual/Base/Remote		Dual: Both main unit and hand mic speakers active Base: Only main unit speaker active Remote: Only hand mic speaker active
Roger Beep	ON/OFF		Enables or disables transmission end tone.
Mic Gain	L1/L2/L3		Microphone sensitivity level.
Busy Lock	ON/OFF		ON: Transmission prohibited during reception. OFF: Transmission permitted during reception.
VFO Step	2.5KHz/5.0KHz/6.25KHz/12.5KHz/25KHz/50KHz/100KHz		Default: 12.5kHz
Reset	Yes/No		Yes: Start resetting. No: Do not reset.
Version			Firmware version.

8. CTCSS Table

CTCSS Number	Frequency Hz	CTCSS Number	Frequency Hz	CTCSS Number	Frequency Hz	CTCSS Number	Frequency Hz
1	67.0	11	97.4	21	136.5	31	192.8
2	71.9	12	100.0	22	141.3	32	203.5
3	74.4	13	103.5	23	146.2	33	210.7
4	77.0	14	107.2	24	151.4	34	218.1
5	79.7	15	110.9	25	156.7	35	225.7
6	82.5	16	114.8	26	162.2	36	233.6
7	85.4	17	118.8	27	167.9	37	241.8
8	88.5	18	123.0	28	173.8	38	250.3
9	91.5	19	127.3	29	179.9		
10	94.8	20	131.8	30	186.2		

9. DCS Table

DCS-N Table

CDCSS Number	Octal Code	CDCSS Number	Octal Code	CDCSS Number	Octal Code	CDCSS Number	Octal Code
1	023N	27	152N	53	311N	79	466N
2	025N	28	155N	54	315N	80	503N
3	026N	29	156N	55	325N	81	506N
4	031N	30	162N	56	331N	82	516N
5	032N	31	165N	57	332N	83	523N
6	036N	32	172N	58	343N	84	526N
7	043N	33	174N	59	346N	85	532N
8	047N	34	205N	60	351N	86	546N
9	051N	35	212N	61	356N	87	565N
10	053N	36	223N	62	364N	88	606N
11	054N	37	225N	63	365N	89	612N
12	065N	38	226N	64	371N	90	624N
13	071N	39	243N	65	411N	91	627N
14	072N	40	244N	66	412N	92	631N
15	073N	41	245N	67	413N	93	632N
16	074N	42	246N	68	423N	94	654N
17	114N	43	251N	69	431N	95	662N
18	115N	44	252N	70	432N	96	664N
19	116N	45	255N	71	445N	97	703N
20	122N	46	261N	72	446N	98	712N
21	125N	47	263N	73	452N	99	723N
22	131N	48	265N	74	454N	100	731N

23	132N	49	266N	75	455N	101	732N
24	134N	50	271N	76	462N	102	734N
25	143N	51	274N	77	464N	103	743N
26	145N	52	306N	78	465N	104	754N

DCS-I Table

CDCSS Number	Octal Code	CDCSS Number	Octal Code	CDCSS Number	Octal Code	CDCSS Number	Octal Code
105	023I	131	152I	157	311I	183	466I
106	025I	132	155I	158	315I	184	503I
107	026I	133	156I	159	325I	185	506I
108	031I	134	162I	160	331I	186	516I
109	032I	135	165I	161	332I	187	523I
110	036I	136	172I	162	343I	188	526I
111	043I	137	174I	163	346I	189	532I
112	047I	138	205I	164	351I	190	546I
113	051I	139	212I	165	356I	191	565I
114	053I	140	223I	166	364I	192	606I
115	054I	141	225I	167	365I	193	612I
116	065I	142	226I	168	371I	194	624I
117	071I	143	243I	169	411I	195	627I
118	072I	144	244I	170	412I	196	631I
119	073I	145	245I	171	413I	197	632I
120	074I	146	246I	172	423I	198	654I
121	114I	147	251I	173	431I	199	662I
122	115I	148	252I	174	432I	200	664I
123	116I	149	255I	175	445I	201	703I
124	122I	150	261I	176	446I	202	712I
125	125I	151	263I	177	452I	203	723I
126	131I	152	265I	178	454I	204	731I
127	132I	153	266I	179	455I	205	732I
128	134I	154	271I	180	462I	206	734I
129	143I	155	274I	181	464I	207	743I
130	145I	156	306I	182	465I	208	754I

Frequency Table

Channel Number	TX Frequency MHz	RX Frequency MHz	Fixed Privacy	Band Width	TX Power
1	462.5625	462.5625	OFF	Narrow	Low (Fixed)
2	462.5875	462.5875	OFF	Narrow	Low (Fixed)
3	462.6125	462.6125	OFF	Narrow	Low (Fixed)
4	462.6375	462.6375	OFF	Narrow	Low (Fixed)
5	462.6625	462.6625	OFF	Narrow	Low (Fixed)
6	462.6875	462.6875	OFF	Narrow	Low (Fixed)
7	462.7125	462.7125	OFF	Narrow	Low (Fixed)
8	RX only	467.5625	OFF	Narrow – Fixed	
9	RX only	467.5875	OFF	Narrow – Fixed	
10	RX only	467.6125	OFF	Narrow – Fixed	
11	RX only	467.6375	OFF	Narrow – Fixed	
12	RX only	467.6625	OFF	Narrow – Fixed	
13	RX only	467.6875	OFF	Narrow – Fixed	
14	RX only	467.7125	OFF	Narrow – Fixed	
15	462.5500	462.5500	OFF	Wide	High
15RP	467.5500	462.5500	OFF	Wide	High
16	462.5750	462.5750	OFF	Wide	High
16RP	467.5750	462.5750	OFF	Wide	High
17	462.6000	462.6000	OFF	Wide	High
17RP	467.6000	462.6000	OFF	Wide	High
18	462.6250	462.6250	OFF	Wide	High
18RP	467.6250	462.6250	OFF	Wide	High
19	462.6500	462.6500	OFF	Wide	High
19RP	467.6500	462.6500	OFF	Wide	High
20	462.6750	462.6750	OFF	Wide	High
20RP	467.6750	462.6750	OFF	Wide	High
21	462.7000	462.7000	OFF	Wide	High
21RP	467.7000	462.7000	OFF	Wide	High
22	462.7250	462.7250	OFF	Wide	High
22RP	467.7250	462.7250	OFF	Wide	High
23					
24					



FCC compliance statement

This device complies with part 15 of the FCC Rules. Operation is subject to the following two conditions: (1) This device may not cause harmful interference, and (2) this device must accept any interference including received interference that may cause undesired operation.

The grantee is not responsible for any changes or modifications not expressly approved by the party responsible for compliance. Such modifications could void the user's authority to operate the equipment. Replacement of any transmitter component (crystal, semiconductor, etc.) not authorized by the FCC equipment authorization for this radio could violate FCC rules.

Note: This equipment has been tested and found to comply with the limits for a Class B digital device, pursuant to part 15 of the FCC Rules. These limits are designed to provide reasonable protection against harmful interference in a residential installation.

This equipment generates, uses, and can radiate radio frequency energy and, if not installed and used in accordance with the instructions, may cause harmful interference to radio communications. However, there is no guarantee that interference will not occur in a particular installation.

If this equipment does cause harmful interference to radio or television reception, which can be determined by turning the equipment off and on, the user is encouraged to try to correct the interference by one or more of the following measures:

- Reorient or relocate the receiving antenna.
- Increase the separation between the equipment and receiver.
- Connect the equipment into an outlet on a circuit different from that to which the receiver is connected.
- Consult the dealer or an experienced radio/TV technician for help.

FCC RF Exposure and Separation Distance

This radio transmitter has been approved by FCC to operate with the antenna types listed below with the maximum permissible gain and required antenna impedance for each antenna type indicated. Antenna types not included in this list, having a gain greater than the maximum gain indicated for that type, are strictly prohibited for use with this device.

External Antenna:

Maximum Antenna Gain: External 50 ohm connector, 0 dBi (Typical)

This equipment complies with FCC radiation exposure limits set forth for an uncontrolled environment. This equipment shall be installed and operated with minimum distance 70 cm between the radiator& body.

WARNING: MODIFICATION OF THIS DEVICE TO RECEIVE CELLULAR RADIOTELEPHONE SERVICE SIGNALS IS PROHIBITED UNDER FCC RULES AND FEDERAL LAW.