

MICROWAVE OVEN

MODEL R-32B(ST)

CONTENTS	Pages
Warranty	i-ii
Warning	1
Special Notes and Warning	2
Oven and Accessories / Installation	3
Control Panel	4
Before Operating	5
Setting the Clock	5
Microwave Power Level	5
Kitchen Timer Function	6
Manual Operation	6
Microwave Cooking	6
Auto Menu Function	7
Other Convenient Functions	8
Weight Defrost Function	9
Time Defrost Function	9
Auto Menu Chart	10
Reheating Advice	11
Care and Cleaning	12
Service Call Check	12
Specifications	12
Manual Chart Guides	A-1
Defrost Times for Meat, Poultry and Bread	A-1
Fresh Vegetable Chart	A-2
Frozen Vegetable Chart	A-3
Rice and Pasta Cooking Chart	A-3
Scrambled Egg Guide	A-3
Reheating/Defrosting Convenience	A-4
Cooking and Utensil Guide	A-5
Helpful Hints	A-6
Notes	

Thank you for buying a Sharp Microwave Oven. Please keep this operation manual handy, as it describes all the features of your oven and will enable you to cook many varieties of foods.

The manual is divided into two sections:

1. OPERATION (P2~P12)

This section describes your oven and teaches you how to use all the features.

2. MANUAL CHART GUIDES

This section is at the back of the manual, it contains the more commonly used information such as how to prepare food, which cooking utensil to use, standing time.

Please take some time to read your operation manual carefully, paying particular attention to the warnings and special notes, the automatic cooking menus programmed into your new oven have been carefully developed to give optimum results when the step by step instructions are followed.

When selecting another home appliance, please again consider our full range of Sharp products.

SHARP

REPLACEMENT WARRANTY

Consumer Electronic Products

Congratulations on Your Purchase!

This Sharp product is warranted against faults in material and manufacture for the period as stated in the table below.

Should you need to make a claim against this warranty please take your product back to the place of purchase.

This warranty does not extend to defects or injuries caused by or resulting from causes not attributable to faulty parts or the manufacture of the product, including but not limited to, defect or injury caused by or resulting from misuse, abuse, neglect, lack of maintenance, accidental damage, improper voltage, liquid spillage, vermin infestation, software, or any alterations made to the product which are not authorised by Sharp.

Please retain your sales documentation, as this should be produced to validate a warranty claim. This warranty is in addition to and in no way limits, varies or excludes any implied rights and remedies under any relevant legislation in the country of sale.

Australian customers: Our goods come with guarantees that cannot be excluded under the Australian Consumer Law. You are entitled to a replacement or refund for a major failure and for compensation for any other reasonably foreseeable loss or damage. You are also entitled to have the goods repaired or replaced if the goods fail to be of acceptable quality and the failure does not amount to a major failure. The criteria of a major failure is defined in the Australian Consumer Law. Should you require any assistance with a major failure please contact Sharp Customer Care.

WARRANTY PERIOD

Microwave Oven	12 months
Small Home Appliances	12 months

SHARP
SHARP CORPORATION OF
AUSTRALIA PTY. LIMITED
ABN 40 003 088 405
2 Julius Avenue
North Ryde NSW 2113

SHARP CORPORATION OF
NEW ZEALAND LIMITED
59 Hugo Johnston Drive
Penrose, Auckland

SPform 040 (NOV 2016)

IMPORTANT NOTICE: This warranty applies only to products sold in Australia & New Zealand

SHARP

FOR LOCATION ENQUIRIES WITHIN

AUSTRALIA

REGARDING YOUR LOCAL

SHARP APPROVED SERVICE CENTRE

VISIT OUR WEBSITE AT

www.sharp.net.au

OR CALL SHARP

LOCAL CALL **1 300 135 022**

SHARP CORPORATION OF AUSTRALIA PTY LTD

SHARP

FOR PRODUCTS PURCHASED

NEW ZEALAND

CONTACT YOUR SELLING DEALER/RETAILER

OR CALL

SHARP CUSTOMER SERVICES

TELEPHONE: 09 573 0111

FACSIMILE: 09 573 0113

WEB: www.sharpnz.co.nz

SHARP CORPORATION OF NEW ZEALAND LIMITED

SPform019(NOV 2016)

**IMPORTANT SAFETY INSTRUCTIONS : READ CAREFULLY AND KEEP FOR FUTURE REFERENCE.**

To reduce the risk of fire in the oven cavity:

- a. Do not overcook food.
- b. Remove wire twist-ties from paper or plastic bags before placing bag in the oven.
- c. Do not heat oil or fat for deep frying. The temperature of the oil cannot be controlled.
- d. Look at the oven from time to time when food is heated in disposable containers made of plastic, paper or other combustible materials for signs of smoke or burning.
- e. If materials inside the oven should ignite, or smoke is observed, keep oven door closed, turn oven off, and disconnect the power plug, or shut off power at the fuse or circuit breaker panel.

To reduce the risk of an explosion or delayed eruptive boiling when handling the container.

Your microwave oven is capable of heating food and beverages very quickly therefore, it is very important that you select the appropriate cooking time and power level for the type and quantity of food to be heated. If you are unsure of the cooking time and power level required, begin with low cooking times and power levels until the food is sufficiently heated evenly throughout.

Additionally:

- a. Do not place sealed containers in the oven. Babies bottles fitted with a screw cap or teat are considered to be sealed containers.
- b. Do not use excessive amount of time.
- c. When boiling liquids in the oven, use a wide-mouthed container.
- d. Stand at least for 20 seconds at the end of cooking to avoid delayed eruptive boiling of liquids.
- e. Stir the liquid before and during cooking. Use extreme care when handling the container or inserting a spoon or other utensil into the container.

This oven is for home food preparation only and should only be used for heating, cooking and defrosting food and beverage.

It is not suitable for commercial, laboratory use, or heating therapeutic devices eg. Wheat bags.

Never operate the oven whilst any object is caught or jammed between the door and the oven.

Do not try to adjust or repair the oven yourself.

It is hazardous for anyone other than a qualified service technician trained by SHARP to carry out any service or repair operation. Especially those which involve the removal of a cover which gives protection against exposure to microwave energy are very hazardous.

Do not operate the oven if it is not working correctly or damaged until it has been repaired by a qualified service technician trained by SHARP. It is particularly important that the oven door closes properly and that there is no damage to:

(1) Door (warped), (2) Hinges and Latches (broken or loosened), (3) Door Seals, Sealing Surfaces and oven cavity (buckled or deformed), (4) Burn marks on the door seal faces.

Do not bump, or catch utensils, loose clothes and your accessories on the door safety latches when removing food from the oven.

Never poke an object, particularly a metal object, through a grille or between the door and the oven while the oven is operating.

Never tamper with or deactivate the door safety latches.

Always use oven gloves to prevent burns when handling utensils that are in contact with hot food. Enough heat from the food can transfer through utensils to cause skin burns.

Should the power supply cord become damaged, it must be replaced with a special cord supplied by a SERVICE CENTRE APPROVED BY SHARP and it must be replaced by a qualified service technician trained by SHARP in order to avoid a hazard.

If the oven lamp fails please consult your dealer or a qualified service technician trained by SHARP.

Avoid steam burns by directing steam away from the face and hands.

Slowly lift the furthest edge of a dish's cover including microwave plastic wrap etc., and carefully open popcorn and oven cooking bags away from the face.

Make sure that the power supply cord is undamaged, and that it does not run under the oven or over any hot surfaces or sharp edges.

To prevent the turntable from breaking:

- a. Before cleaning the turntable with water, leave the turntable to cool.
- b. Do not place anything hot on a cold turntable.
- c. Do not place anything cold on a hot turntable.

Do not place anything on the outer cabinet.

Do not store food or any other items inside the oven.

Make sure the utensil does not touch the interior walls during cooking.

Only allow children to use the oven without supervision when adequate instructions have been given so that the child is able to use the oven in a safe way and understands the hazards of improper use.

This appliance is not intended for use by persons (including children) with reduced physical, sensory or mental capabilities, or lack of experience and knowledge, unless they have been given supervision or instruction concerning use of the appliance by a person responsible for their safety.

Children should be supervised to ensure that they do not play with the appliance.



SPECIAL NOTES & WARNING

	DO	DON'T
Eggs, fruits, vegetables, nuts, seeds, sausages and oysters	<ul style="list-style-type: none"> * Puncture egg yolks and whites and oysters before cooking to prevent "explosion". * Pierce skins of potatoes, apples, squash, hot dogs, sausages and oysters so that steam escapes. 	<ul style="list-style-type: none"> * Cook eggs in shells. This prevents "explosion", which may damage the oven or injure yourself. * Cook hard/soft boiled eggs. * Overcook oysters. * Dry nuts or seeds in shells.
Popcorn	<ul style="list-style-type: none"> * Use specially bagged popcorn for the microwave oven. * Listen while popping corn for the popping to slow to 1-2 seconds. 	<ul style="list-style-type: none"> * Pop popcorn in regular brown bags or glass bowls. * Exceed maximum time on popcorn package.
Baby food	<ul style="list-style-type: none"> * Transfer baby food to small dish and heat carefully, stirring often. Check for suitable temperature to prevent burns. * Remove the screw cap and teat before warming baby bottles. After warming shake thoroughly. Check for suitable temperature. 	<ul style="list-style-type: none"> * Heat disposable bottles. * Overheat baby bottles. Only heat until warm. * Heat bottles with nipples on. * Heat baby food in original jars.
General	<ul style="list-style-type: none"> * Food with filling should be cut after heating, to release steam and avoid burns. * Use a deep bowl when cooking liquids or cereals to prevent boiling over. 	<ul style="list-style-type: none"> * Heat or cook in closed glass jars or airtight containers. * Deep fat fry. * Heat or dry wood, herbs, wet papers, clothes or flowers. * Operate the oven without a load (i.e. an absorbing material such as food or water) in the oven cavity.
Liquids (Beverages)	<ul style="list-style-type: none"> * For boiling or cooking liquids see WARNING on page 2 to prevent explosion and delayed eruptive boiling. 	<ul style="list-style-type: none"> * Heat for longer than recommended time. See REHEATING-FOOD CHART on page10.
Canned foods	<ul style="list-style-type: none"> * Remove food from can. 	<ul style="list-style-type: none"> * Heat or cook food while in cans.
Sausage rolls, Pies, Christmas pudding	<ul style="list-style-type: none"> * Cook for the recommended time. (These foods have high sugar and/or fat contents.) 	<ul style="list-style-type: none"> * Overcook as they may catch fire.
Meats	<ul style="list-style-type: none"> * Use a microwave proof roasting rack to collect drained juices. 	<ul style="list-style-type: none"> * Place meat directly on the turntable for cooking.
Utensils	<ul style="list-style-type: none"> * Check the utensils are suitable for MICROWAVE cooking before you use them. 	<ul style="list-style-type: none"> * Use metal utensils for MICROWAVE cooking. Metal reflects microwave energy and may cause an electrical discharge known as arcing.
Aluminium foil	<ul style="list-style-type: none"> * Use to shield food to prevent over cooking. * Watch for sparking. Reduce foil or keep clear of cavity walls. 	<ul style="list-style-type: none"> * Use too much. * Shield food close to cavity walls. Sparking can damage the cavity.
Browning dish	<ul style="list-style-type: none"> * Place a suitable insulator such as a microwave and heat proof dinner plate between the turntable and the browning dish. 	<ul style="list-style-type: none"> * Exceed the preheating time recommended by the manufacturer. Excessive preheating can cause the glass turntable to shatter and/or damage internal parts of the oven.

OVEN AND ACCESSORIES

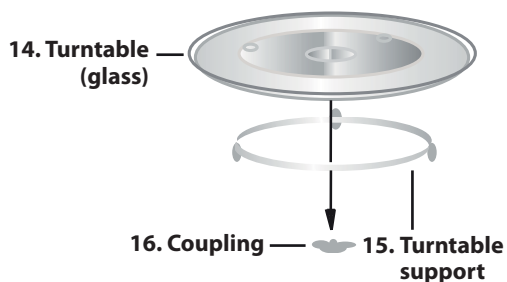
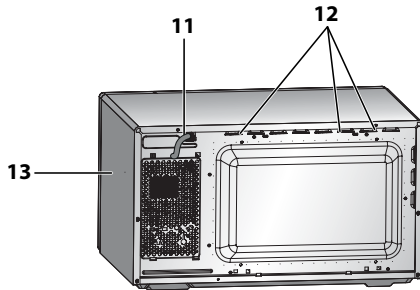
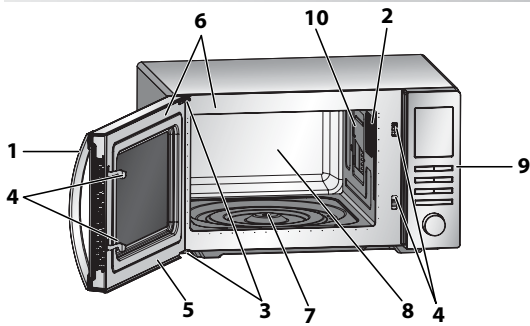

OVEN

1. Door handle
2. Oven lamp
3. Door hinges
4. Door safety latches
5. Door
6. Door seals and sealing surfaces
7. Turntable motor shaft
8. Oven cavity
9. Control panel
10. Waveguide cover (DO NOT REMOVE)
11. Power supply cord
12. Ventilation openings
13. Outer cabinet

ACCESSORIES:

Check to make sure the following accessories are provided:

(14) Turntable (15) Turntable support (16) Coupling

- Place the coupling into the turntable motor shaft and then place the turntable support in the centre of the oven floor so that it can freely rotate around the coupling. Place the turntable onto the turntable support so that it locates firmly into the coupling.
- To avoid turntable damage, ensure dishes and containers are lifted clear of the turntable rim when removing them from the oven.

NOTE: When you order accessories, please mention two items: part name and model name to your dealer or SHARP authorised service agent.







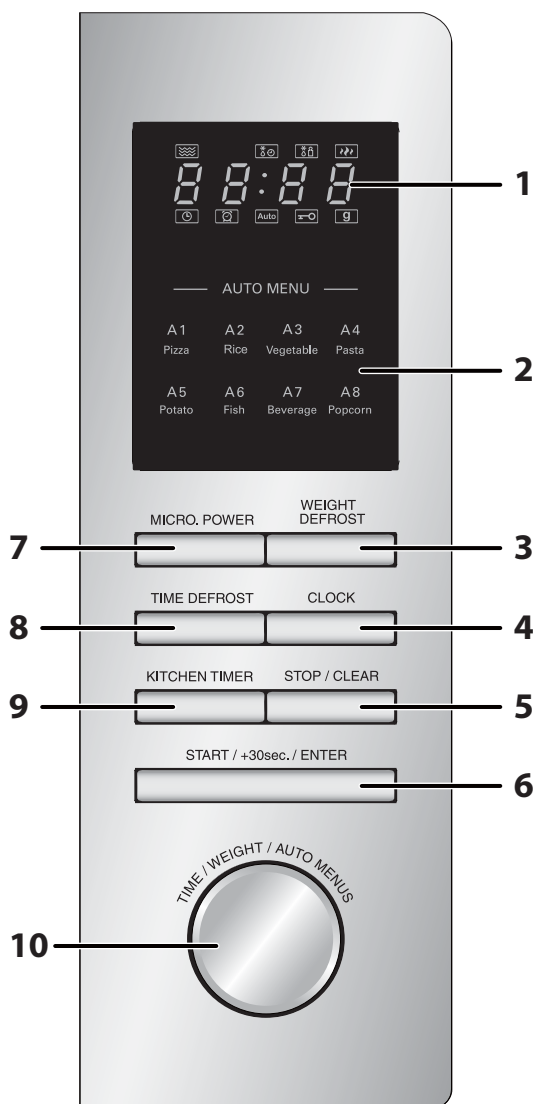

INSTALLATION INSTRUCTIONS

1. Remove all packing materials from the oven cavity, (**do not remove the waveguide cover**), and the feature sticker from the outside of the door, if there is one. Check the unit for any damage, such as a misaligned door, damaged door seals around the door or dents inside the oven cavity or on the door. If there is any damage, please do not operate the oven until it has been checked by a **SERVICE CENTRE APPROVED BY SHARP** and repaired, if necessary.
2. Accessories provided
 - 1) Turntable 2) Turntable support
 - 3) Coupling 4) Operation manual
3. Ensure that the coupling is installed. Place the turntable support on the oven floor, then place the turntable onto the turntable support and coupling, ensuring it is located firmly. Refer to the diagram above. **NEVER** operate the oven without the turntable.
4. This oven is designed for countertop or cabinet use as well. It should not be installed in any area where excessive heat and steam are generated, for example, next to a conventional oven unit. The oven should be installed so as not to block ventilation openings. Allow a space of at least 10 cm on the top, 5 cm on both sides and at the rear of the oven for adequate air circulation.
WARNING: The electrical outlet must be readily accessible so that the unit can be unplugged easily in an emergency.
5. Neither the manufacturer nor the distributors can accept any liability for damage to the machine or personal injury for failure to observe the correct electrical connecting procedure.
 The A.C. voltage must be single phase 230 – 240V, 50Hz.
6. This appliance must be earthed.
7. Operate the oven from a general purpose domestic outlet.
 If a generator is used, do not operate the oven with non-sinusoidal outputs.

CONTROL PANEL



1. DIGITAL DISPLAY and INDICATORS

-  MICROWAVE indicator
-  TIME DEFROST indicator
-  WEIGHT DEFROST indicator
-  POWER LEVEL indicator
-  CLOCK indicator
-  KITCHEN TIMER indicator
-  AUTO MENU indicator
-  CHILD LOCK indicator
-  WEIGHT indicator

2. Auto Menu options

- A1: Pizza
- A2: Rice
- A3: Vegetables
- A4: Pasta
- A5: Potato
- A6: Fish
- A7: Beverage
- A8: Popcorn

3. WEIGHT DEFROST button

4. CLOCK button

5. STOP/CLEAR button

6. START / +30sec./ENTER button

7. MICRO. POWER button

8. TIME DEFROST button

9. KITCHEN TIMER

10. ENTRY dial

Rotate to enter the cooking time, time of day, power level, weight and to select an auto menu



BEFORE OPERATION

Plug in the oven. The oven display will display: "0:00", an audible signal will sound once.

This model has a clock function and the oven uses less than 1.0 W in stand by mode.

SETTING THE CLOCK

Your oven has a 24 hour clock feature. To set the clock:

1. Press the **CLOCK** button once. The hour figure will flash and the clock indicator will illuminate.
2. Rotate the **ENTRY** dial until the correct hour is displayed, the input time should be within 0-23.
3. Press the **CLOCK** button, the minute figure will flash.
4. Rotate the **ENTRY** dial until the correct minutes are displayed, the input time should be within 0-59.
5. Press the **CLOCK** button to confirm the time. The icon ":" of the digital time will flash on the display and the clock indicator will disappear.

NOTES:

- If the clock is set, when cooking is complete, the display will show the correct time of day. If the clock has not been set, the display will show "0:00".
- To check the time of day during a cooking process, press the **CLOCK** button and the LED will display the time of day for 2-3 seconds. This does not affect the cooking process.
- In the process of clock setting, if the **STOP/CLEAR** button is pressed, the oven will go back to the former setting.
- If the electrical power supply to your microwave oven is interrupted, the display will intermittently show "0:00" after the power is reinstated. If this occurs during cooking, the programme will be erased, as will the time of day.

MICROWAVE POWER LEVEL

Power Level	Press the POWER LEVEL key	Display (Percentage)
HIGH	x1	P100
	x2	P90
MEDIUM HIGH	x3	P80
	x4	P70
MEDIUM	x5	P60
	x6	P50
MEDIUM LOW (DEFROST)	x7	P40
	x8	P30
LOW	x9	P20
	x10	P10
	x11	P0

- Press the **MICRO. POWER** button once, P100 will be displayed and at the same time the microwave indicator and power level indicator will illuminate on the display.
- Press **MICRO. POWER** or rotate the **ENTRY** dial to change the power level until the display indicates the desired level.
- Press the **START/+30sec./ENTER** button to confirm the setting, enter the cooking time and then press the **START/ +30sec./ENTER** button again to start the oven.
- To check the power level during cooking, press the **MICRO. POWER** button, the current power level will be displayed for 3 seconds. The oven will continue to count down although the display will show the power level.
- If "P0" is selected, the oven will work with the fan but no power. You can use this level to remove the odour.

Generally the following recommendations apply:

P100/ P90 - (HIGH) used for fast cooking or reheating e.g. for casseroles, hot beverages, vegetables etc.

P80/ P70 - (MEDIUM HIGH) used for longer cooking of dense foods such as roast joints, meat loaf and plated meals, also for sensitive dishes such as sponge cakes. At this reduced setting, the food will cook evenly without over cooking at the sides.

P60/ P50 - (MEDIUM) for dense foods which require a long cooking time when cooked conventionally, e.g. beef casserole, it is advisable to use this power setting to ensure the meat will be tender.

P40/ P30 - (MEDIUM LOW) to defrost, select this power setting, to ensure that the dish defrosts evenly. This setting is also ideal for simmering rice, pasta, dumplings and cooking egg custard.

P20/ P10 - (LOW) For gentle defrosting, e.g. cream gateaux or pastry.

KITCHEN TIMER FUNCTION

You can use the kitchen timer function in instances where microwave cooking is not involved, for example, to time boiled eggs cooked on conventional hob or to monitor the standing time for cooked/defrosted food.

Example:

To set the timer for 5 minutes.

1. Press **KITCHEN TIMER** button once.
2. Rotate **ENTRY** dial to select time .
3. Press the **START/ +30sec/ENTER** key to start the timer.
4. Check the display. (The display will count down through the programmed time.)

When the timer arrives at 0:00, an audible signal will sound 5 times and the LED will then display the time of day. You can enter any time up to 95 minutes. To cancel the **KITCHEN TIMER** whilst counting down, simply press the **STOP/CLEAR** button.

NOTE: The **KITCHEN TIMER** function cannot be used whilst cooking.

MANUAL OPERATION

Opening the door:

To open the oven door, pull the door handle.

Starting the oven:

Depending on the food type and the required end results, either place food into a suitable container, then place the container onto the turntable, alternatively place foods directly onto the turntable. Close the door and press the **START/ +30sec./ENTER** button after selecting the desired cooking mode.

Once the cooking programme has been set if the **START/ +30sec./ENTER** button is not pressed in 1 minute, the setting will be cancelled. The **START/ +30sec./ENTER** button must be pressed to continue cooking if the door is opened during cooking. An audible signal will sound once when pressing the button, if inefficiently pressed there will be no sound.

Use the **STOP/CLEAR** button to:

1. Erase a mistake during programming.
2. Stop the oven temporarily during cooking.
3. Cancel a programme during cooking, press the **STOP/CLEAR** button twice.
4. To set and to cancel the child lock .

MICROWAVE COOKING

Your oven can be programmed for up to 95 minutes (95:00). The input unit of cooking /defrosting time varies from 5 seconds to 95 minutes. It depends on the total length of the cooking/defrosting time as shown on the table.

Cooking Time	Increasing Unit
0-1 minute	5 seconds
1-5 minutes	10 seconds
5-10 minutes	30 seconds
10-30 minutes	1 minute
30-95 minutes	5 minutes

MANUAL COOKING/MANUAL DEFROSTING

- Enter the cooking time and use the microwave power levels P100 to P10 to cook or defrost .
- Stir or turn the food, where possible, 2 - 3 times during cooking.
- After cooking, cover the food and leave to stand, where recommended.
- After defrosting, cover the food in foil and leave to stand until thoroughly defrosted.

MICROWAVE COOKING

Example:

To cook for 2 minutes and 30 seconds on P80 (80%) microwave power.

1. Press the **MICRO. POWER** button. P100 will be displayed.
2. Rotate the **ENTRY** dial to select the power level for P80.
3. Press the **START/ +30sec./ENTER** button to confirm the setting.
4. Enter the cooking time by rotating the **ENTRY** dial.



5. Press the **START/ +30sec./ENTER** button to start cooking. (The display will count down through the programmed cooking time.)



NOTE:

- When the oven starts, the oven lamp will illuminate and the turntable will rotate clockwise or anticlockwise.
- If the door is opened during cooking/defrosting to stir or turn over food, the cooking time on the display will stop automatically. Cooking/defrosting time starts to count down again when the door is closed and the **START/ +30sec./ENTER** button is pressed.
- When cooking/defrosting is complete, the time of day will reappear on the display, if the clock has been set.
- If you wish to know the power level during cooking, press the **MICRO. POWER** button. The current power level will be displayed for 3 seconds.

AUTO MENU FUNCTION

The **AUTO MENU** programme automatically calculates the correct cooking mode and cooking time of foods. Follow the example below for guidance on how to operate this function.

Example: To cook fish with a weight of 250g by using the **AUTO MENU** function.

1. Rotate the **ENTRY** dial to select the desired auto menu.
2. Press the **START/ +30sec./ENTER** button to confirm the setting.
3. Enter the desired weight by rotating the **ENTRY** dial.



4. Press the **START/ +30sec./ENTER** button to start cooking. (The display will count down through the programmed cooking time.)



NOTES:

- The weight or quantity of the food can be input by rotating the **ENTRY** dial until the desired weight/quantity ('g' or ml) illuminates on the display. Enter the weight of the food only. Do not include the weight of the container.
- For food weighing more or less than the weights/quantities given in the **AUTO MENU** chart cook by manual operation.

OTHER CONVENIENT FUNCTIONS

1. SEQUENCE COOKING

This function allows you to cook using up to 2 different stages which can include manual cooking times or time defrost as well as a weight defrost function. Once programmed there is no need to interfere with the cooking operation as the oven will automatically move onto the next stage. An audible signal will sound once after the first stage. If the defrost function is needed within sequence cooking, please note that this should always be the first stage of sequence cooking.

NOTE: AUTO MENU cannot be set as one of the multiple sequences.

Example: If you want to cook food for 20 minutes on P100 microwave power and then for 5 minutes with P80 microwave power. The steps are as follows:

1. Press the **MICRO. POWER** button, P100 will appear in the LED display.
2. Press the **START/+30sec./ENTER** button once to confirm the setting.
3. Enter the cooking time by rotating the **ENTRY** dial until the display shows "20:00" minutes.
4. Press the **MICRO. POWER** button, P100 will appear in the LED display.
5. Press the **MICRO. POWER** button twice or rotate the **ENTRY** dial to select the microwave power to P80.
6. Press the **START/+30sec./ENTER** button once more to confirm the setting.
7. Enter the cooking time by rotating the **ENTRY** dial until the display shows "5:00" minutes.
8. Press the **START/ +30sec./ENTER** button to start cooking.

2. +30sec FUNCTION / Direct Start

Direct start

You can directly start cooking on P100 microwave power level for 30 seconds by pressing the **START/ +30sec./ENTER** button. The cooking process will start immediately and each time the button is pressed this will increase the cooking time by 30 sec.

NOTE: The cooking time may be extended to a maximum of 95 minutes.

3. CHILD LOCK:

Use to prevent unsupervised operation of the oven by children.

a. To set the CHILD LOCK:

In the stand-by mode, press **STOP/CLEAR** button for 4 seconds. There will be a long beep denoting entering the children-lock state and the  indicator will illuminate together with the current clock time. If the clock has not been set the display status will be as follows:

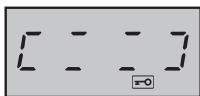

b. To cancel the CHILD LOCK:

In the stand-by mode, press **STOP/CLEAR** button for 4 seconds. There will be a long "beep" denoting that the lock is released.

WEIGHT DEFROST FUNCTION

WEIGHT DEFROST

The microwave oven is pre-programmed with a timer and power level so that foods such as pork, beef and chicken can be easily defrosted.

The weight range for this is from 100g – 2000g in 500g steps (100g,500g,1000g,1500g,2000g). Follow the example below for guidance on how to operate this function.

Example: To defrost a meat joint weighing 1kg using **WEIGHT DEFROST**.

Place the meat in a microwave safe defrosting dish with rack and place onto the turntable.

1. Press the **WEIGHT DEFROST** button once.
2. Enter the desired weight by rotating the **ENTRY** dial until the display shows:
3. Press the **START/ +30sec./ENTER** button to start defrosting. (The display will count down through defrosting time)

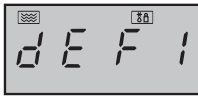

NOTE:

- The size and shape of the piece of meat can cause variations in defrosting results.
- Frozen foods are defrosted from -18°C.
- Before freezing foods, ensure food is fresh and of good quality.
- If necessary, shield small areas of meat or poultry with flat pieces of aluminium foil. This will prevent the areas from becoming warm during defrosting. Ensure the foil does not touch the oven walls.
- Food weight should be rounded up to the nearest 100g, for example, 650g to 700g.
- After defrosting an audible signal will sound five times and the LED will then display time of day, if the clock has been set. If the clock has not been set, the display will only show "0:00" when defrosting is complete.
- Turn meat over halfway through cooking time.

TIME DEFROST FUNCTION

TIME DEFROST

This function quickly defrosts food while enabling you to choose a suitable defrost period, depending on the food type. Follow the example below for guidance on how to operate this function. The time range is 0:05 – 95:00.

Example: To defrost food for 10 minutes.

1. Press the **TIME DEFROST** button.
2. Enter the cooking time by rotating the **ENTRY** dial until the display shows: 10:00
3. Press the **START/ +30sec./ENTER** button to start defrosting. (The display will count down through defrosting time)



Notes for Time Defrost:

- The preset microwave power level can not be changed.
- Before freezing foods, ensure food is fresh and of good quality.
- If necessary, shield small areas of meat or poultry with flat pieces of aluminium foil. This will prevent the areas from becoming warm during defrosting. Ensure the foil does not touch the oven walls.
- After defrosting an audible signal will sound five times and the LED will then display the time of day, if the clock has been set. If the clock has not been set, the display will only show "0:00" when defrosting is complete.





AUTO MENU CHART

Auto Menu	Display	Cooking method	WEIGHT/ PORTION / UTENSILS	Procedure
Chilled pizza	A-1	100% Micro	2 slices, 4 slices. 1 slice = Approx. 90g. (initial temp. 3°C) Plate	Place the pizza slices onto a microwave safe plate. Do not cover. Place the plate onto the centre of the turntable.
White Rice	A-2	100% Micro	Rice Hot Tap Water 1 cup 2 cups 2 cups 4 cups 4 cups 6 cups Microwave safe deep bowl	Pre-wash the rice under running water until the water runs clear. Place rice in an appropriately sized microwave safe bowl and add the hot tap water. Do not cover. When the microwave beeps, stir and press START to resume cooking. After cooking, stand for 2 minutes before serving.
Fresh vegetables e.g. cauliflower, carrots, broccoli	A-3	100% Micro	200g, 300g, 400g (initial temp 3°C) Microwave safe dish and lid/cling wrap	Cut vegetables into evenly sized pieces. Place the vegetables into a microwave safe dish and cover with a lid or plastic wrap. Place the dish on the centre of the turntable. Stir halfway through cooking.
Pasta (dried pasta e.g. Fusilli, Farfalle, Rigatoni)	A-4	100% Micro	Pasta Cold Tap Water 1Cup 2 1/2 Cups 2Cups 4 1/2 Cups 4Cups 8 Cups	Place the pasta in an appropriately sized microwave safe bowl and add the hot tap water. Do not cover. Place the bowl on the centre of the turntable. When microwave beeps, stir and press START to resume cooking. After cooking, stand for 2 minutes for before serving.
Jacket potatoes	A-5	100% Micro	1, 2, and 3 Potatoes. 1 Potato = Approx. 180-220g (Initial temp 20°C)	Use potatoes that are of a similar size. Pierce the potato several times on all sides and place directly onto the turntable. When the microwave beeps, turnover the potatoes and press START to resume cooking. Allow to stand before consuming.
Fish (fillet)	A-6	80% Micro	250g, 350g, 450g (initial temp. 3°C) Flan dish and vented microwave cling film or suitable lid	Place the fish into a microwave safe dish and place onto the centre of the turntable. When the microwave beeps, turnover fish and press START to resume cooking.
Beverage	A-7	100% Micro	1 (250ml) 2 (500ml) (initial temp.3°C)	Place the mug/s onto the outside rim of the turntable. Stir after cooking.
Popcorn	A-8	100% Micro	100g	Place the popcorn bag as instructed on the packaging onto the centre of the turntable.

- The results when using the Auto Menus depend on variations such as the shape, size and initial temperature of the food and your personal preference in regards to cooking results. If you are not satisfied with the programmed result, please adjust the cooking time to match your requirement.

REHEATING ADVICE

For the reheating of foods, follow the advice and guidelines below to ensure food is thoroughly reheated before serving.

<p>Plated meals</p>	<p>Remove any poultry or meat portions, reheat these separately, see below. Place smaller items of food to the centre of the plate, larger and thicker foods to the edge. Cover with vented microwave cling film and reheat on 70%, stir/rearrange halfway through reheating. NOTE: Ensure the food is thoroughly reheated before serving.</p>	
<p>Sliced meat</p>	<p>Cover with vented microwave cling film and reheat on 50%. Rearrange at least once to ensure even reheating. NOTE: Ensure the meat is thoroughly reheated before serving.</p>	
<p>Poultry portions</p>	<p>Place thickest parts of the portions to the outside of the dish, cover with vented microwave cling film and reheat on 70%. Turn over halfway through reheating. NOTE: Ensure the poultry is thoroughly reheated before serving.</p>	
<p>Casseroles</p>	<p>Cover with vented microwave cling film or a suitable lid and reheat on 50%. Stir frequently to ensure even reheating. NOTE: Ensure the food is thoroughly reheated before serving.</p>	

To achieve the best results when reheating, select a suitable microwave power level appropriate to the type of food. e.g. A bowl of vegetables can be reheated using 100%, while a lasagne which contains ingredients that cannot be stirred, should be reheated using 50%.

NOTES:

- Remove food from foil or metal containers before reheating.
- Reheating times will be affected by the shape, depth, quantity and temperature of food together with the size, shape and material of the container.

⚠ WARNING:
Never heat liquids in narrow-necked containers, as this could result in the contents erupting from the container and may cause burns.

- To avoid overheating and fire, special care must be taken when reheating foods with a high sugar or fat content, e.g. mince pies or Christmas pudding.
- Never heat oil or fat for deep frying as this may lead to overheating and fire.
- Canned potatoes should not be heated in the microwave oven, follow the manufacturer's instructions on the can.

⚠ WARNING:
The contents of feeding bottles and baby food jars are to be stirred or shaken and the temperature is to be checked before consumption to avoid burns.



CARE AND CLEANING

Disconnect the power supply cord before cleaning or leave the door open to inactivate the oven.

CLEAN THE OVEN AT REGULAR INTERVALS - Keep the oven clean and remove any food deposits, or it could lead to deterioration of the surface. This could adversely affect the life of the appliance and possibly result in a hazardous situation.

Exterior:

The outside may be cleaned with mild soap and warm water, wipe clean with a damp cloth. Avoid the use of harsh abrasive cleaners. Keep the ventilation openings free of dust.

Door:

Wipe the door and window on both sides, the door seals and adjacent parts frequently with a damp cloth to remove any spills or splatters. Do not use abrasive cleaners.

Touch Control Panel:

Wipe the panel with a cloth dampened slightly with water only.

Do not scrub or use any sort of chemical cleaners. Avoid the use of excess water.

Interior walls:

To clean the interior surfaces, wipe with a soft cloth and warm water. After use wipe the waveguide cover in the oven with a soft damp cloth to remove any food splashes. Built-up splashes may overheat and begin to smoke or catch fire. Do not remove the waveguide cover. **DO NOT USE A COMMERCIAL OVEN CLEANER, ABRASIVE OR HARSH CLEANERS AND SCOURING PADS ON ANY PART OF YOUR MICROWAVE OVEN. NEVER SPRAY OVEN CLEANERS DIRECTLY ONTO ANY PART OF YOUR OVEN.**

Avoid using excess water. After cleaning the oven, ensure any water is removed with a soft cloth.

Turntable/Roller Stay:

Wash with mild soapy water and dry thoroughly.



SERVICE CALL CHECK

Please check the following before calling for service:

1. Place one cup of water (approx. 250 ml) in a glass measure in the oven and close the door securely.

Press the **START/+30sec./ENTER** button four times.

A. Does the oven lamp come on? YES _____ NO _____

B. Does the cooling fan work? YES _____ NO _____

(Put your hand over the rear ventilation openings.)

C. Does the turntable rotate? YES _____ NO _____

(The turntable can rotate clockwise or counterclockwise. This is quite normal.)

D. After two minutes, did an audible signal sound and COOK indicator go off? YES _____ NO _____

E. Is the water inside the oven hot? YES _____ NO _____

If "NO" is the answer to any of the above questions, please check your wall socket and the fuse in your meter box.

If both the wall socket and the fuse are functioning properly, CONTACT YOUR NEAREST SERVICE CENTRE APPROVED BY SHARP.



SPECIFICATIONS

AC Line Voltage	Single phase 230–240V, 50Hz
AC Power Required	1450W
Output Power	900 W* (IEC test procedure)
Microwave Frequency	2450 MHz (Class B/Group 2)**
Outside Dimensions (W x H x D)	513 x 306 x 429mm
Turntable	315mm
Weight	15kg

* When tested in accordance with AS/NZS 2895.1:2007

** This is the classification of ISM (Industrial, Scientific and Medical) equipment described in the International Standard CISPR11.

Defrost Times for Meat, Poultry, Bread and Pies

1. Remove wrapping and place frozen item on a shallow microwave safe plastic defrost rack. If necessary, shield thin areas with aluminium foil to prevent the item from cooking while defrosting
2. Defrost by following the steps in the “Microwave Time” column.
3. Set the microwave to 30% power.
4. When turning over, re-shield any warm areas so it continues to defrost without cooking

CUT	MICROWAVE TIME	STANDING TIME
BEEF (Roast) Steaks Minced Beef	6-8 minutes / 500g 7-9 minutes / 500g 7-9 minutes / 500g	20 minutes or until defrosted 5 – 10 minutes 5 – 10 minutes
PORK (Roast) Chops Ribs Minced Pork	7-9 minutes / 500g 9-11 minutes / 500g 7-9 minutes / 500g 8-10 minutes / 500g	20 minutes or until defrosted 5 – 10 minutes 5 – 10 minutes 5 – 10 minutes
LAMB (Roast) Chops	7-8 minutes / 500g 8-10 minutes / 500g	20 minutes or until defrosted 5 – 10 minutes
POULTRY Chicken (Whole) Pieces	7-9 minutes / 500g 8-9 minutes / 500	20 minutes or until defrosted 5 – 10 minutes

BREAD / PIES	MICROWAVE TIME	PROCEDURE
2 Slices of Bread	50 seconds	Place between paper towel and place directly on the turntable.
4 Slices of Bread	1 minute 20 seconds	
1 Bread Roll	1 minutes 10 seconds	
2 Bread Rolls	2 minutes	

MANUAL CHART GUIDES

Microwave: Fresh Vegetable Chart

1. Cover required dishes with plastic wrap or a lid.
2. Drain any remaining water after standing before serving.

Vegetable	Amount	Microwave Time at 100%	Cooking Procedure
Asparagus (halved)	250g	4 – 5 minutes	Place in a shallow microwave safe dish with 1 tablespoon water. Cover. Stand for 3 minutes
Beans (top and tailed)	500g	5 – 7 minutes	Place in a shallow microwave safe dish with 1 tablespoon of water. Cover. Stand for 3 minutes
Broccoli (uniform florets)	500g	5 – 7 minutes	Place in a shallow microwave safe dish with 1 tablespoon water. Cover. Stand for 3 minutes
Brussels Sprouts	250g	4 – 6 minutes	Place in a shallow microwave safe dish with 1 tablespoon water. Cover. Stand for 3 minutes
Cabbage (shredded)	500g	7 – 9 minutes	Place in a shallow microwave safe dish with 2 tablespoons of water. Cover. Stand for 3 minutes
Carrots (sliced)	500g	6 – 8 minutes	Place in a shallow microwave safe dish. Cover. Stand for 3 minutes (cook for longer for less crunch)
Cauliflower (uniform florets)	500g	6 – 8 minutes	Place in a shallow microwave safe dish with 1 tablespoon of water. Cover. Stand for 3 minutes
Corn on the Cob	2 pieces	6½ – 8½ minutes	Place in a shallow microwave safe dish. Cover. Stand for 3 minutes.
Mushrooms (quartered)	500g	5 – 7 minutes	Place in a shallow microwave safe dish with 2 tablespoons of butter. Cover. Stand for 3 minutes
Potatoes	4 medium	10 – 12 minutes	Peel and cut potatoes into eights. Cook in a dish with 1 cup water. Cook covered. Stand for 3 minutes.
Pumpkin (2cm cubes)	500g	6 – 8 minutes	Place in a shallow microwave safe dish. Cover. Stand for 3 minutes
Spinach (shredded)	250g	6 – 8 minutes	Place in a shallow microwave safe dish with 2 tablespoons of water. Cover. Stand for 3 minutes
Snow Peas (top and tailed)	250g	3 – 4 minutes	Place in a shallow microwave safe dish with 1 tablespoon of water. Cover. Stand for 3 minutes
Squash (whole)	250g	4 – 5 minutes	Pierce with a fork. Place in a shallow microwave safe dish. Cover. Stand for 3 minutes
Sweet Potato (2cm cubes)	500g	7 – 9 minutes	Place in a shallow microwave safe dish with 2 tablespoons water. Cover. Stand for 3 minutes
Zucchini (sliced)	500g	5 – 7 minutes	Place in a shallow microwave safe dish with 1 tablespoon of water. Cover. Stand for 3 minutes

Frozen Vegetable Chart

1. Place vegetables in a medium/large microwave safe bowl and cover with plastic wrap.
2. Halfway through cooking, stir the vegetables to ensure even cooking.
3. Allow to stand for 2 minutes before draining any water and serving.

Vegetable	Weight	Microwave Time (100%)	Special Procedures
Beans (green, cut)	500g	9 – 10 minutes	
Broccoli	500g	9 – 10 minutes	Break apart as soon as possible. Arrange with flower towards the centre.
Carrots (whole)	500g	9 – 11 minutes	
Cauliflower	500g	9 – 11 minutes	Break apart as soon as possible. Arrange with flower towards the centre.
Corn on the Cob	4 pieces	7 – 8 minutes	
Peas (green)	500g	9 – 10 minutes	
Spinach	250g	5 – 6 minutes	Break apart as soon as possible.
Mixed Vegetables (i.e. carrots, beans and corn kernels)	500g	9 – 11 minutes	Break apart as soon as possible.

Rice and Pasta Cooking Chart

1. Wash and strain rice before measuring amounts.
2. Place rice/pasta in a medium/large microwave safe bowl with water. Cook uncovered, stirring halfway through cooking. Allow to stand for 2 minutes before straining any remaining water and serving.

Food		Other Ingredients	Cooking Time
Pasta	1 Cup	2 cups Hot Water	15 minutes
	2 Cups	4 cups Hot Water	18 minutes
	4 Cups	6 cups Hot Water	25 minutes
White Rice	1 Cup	2 cups Hot Water	19 minutes
	2 Cups	4 cups Hot Water	22 minutes
	4 Cups	6 cups Hot Water	30 minutes
Quick Oats	1 Cup	1½ cups Milk	5 minutes

Scrambled Egg Guide

Place butter, eggs and milk in a small/medium microwave safe bowl. Beat with a fork until well combined and yolks of eggs are completely stirred in. Cook uncovered, stirring halfway through cooking.

Egg(s)	Butter	Milk	Cooking Medium High (80%)
1	1 tsp	1 tbsp	1½ minutes
2	2 tsp	1 tbsp	2½ minutes
3	1 tbsp	2 tbsp	3½ minutes
4	1 tbsp	¼ cup	5 minutes







MANUAL CHART GUIDES

Reheating / Defrosting Convenience Food Chart

FOOD	WEIGHT	COOKING TIME AND POWEL LEVEL	SPECIAL INSTRUCTIONS	STANDING TIME
Beverage (refrigerated) 250mL per cup	1 cup 2 cups	1 minute / 50 seconds / 100% 3½ minutes / 100%	Stir after heating.	-
Canned Food (room temp.) (e.g. Spaghetti, Baked Beans)	1 cup 2 cups	5 minutes / 50% 9 minutes / 50%	Place food in bowl. Cover with plastic wrap and pierce 5 times with a skewer. Stir halfway.	1-3 minutes
Canned Soup (room temp) 250mL per cup (thin soup)	1 cup 2 cups	2 minutes / 100% 3½ minutes / 100%	Place food in bowl. Cover with plastic wrap or lid. Stir halfway.	-
Meat Pie (refrigerated) Individual 180g each	1 pie 4 pies	6½ minutes / 50% 15 minutes / 50%	Place directly on turntable, face side down. Cover with paper towel. Turn over halfway.	3 minutes
Frozen Rice/Pasta Dinners (e.g. Lasagne, Risotto)	300-500g	10 minutes / 100%	Remove from foil container. Cover with plastic wrap or lid. Allow to stand	2 minutes
Dinner Plate (refrigerated) 350g-400g per serve	1 serve	7 minutes / 80%	Slice potato. Cover plate with plastic wrap and pierce 5 times with a skewer. Place directly on turntable. Allow to stand.	3 minutes
Casserole (refrigerated) 300g serve	1 serve	3½ minutes / 100%	Place in a bowl, cover with plastic wrap. Place directly on turntable. Stir halfway. Allow to stand, then stir.	1-3 minutes
Croissants (frozen)	1 2	2 minutes / 30% 3 minutes / 30%	Place between paper towels. Place directly on the turntable.	-
Fruit Pie individual (frozen) 135g each	1 2	5½ minutes / 30% 9 minutes / 30%	Remove from foil container. Place on a plate and then onto the turntable. Allow to stand.	2 minutes
Danish Pastry whole (frozen)	400g	5 minutes / 80% then 4½ minutes / 30%	Remove from foil container. Place on dinner plate. Allow to stand.	2 minutes

NOTE: Room Temperature +20°C
Refrigerator Temperature +3°C
Frozen Temperature -18°C

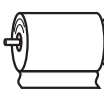
COOKING AND UTENSIL GUIDE

Utensil	Use	Advice
GLASSWARE/CERAMIC (HEAT RESISTANT) 	YES	<p>GLASSWARE</p> <ul style="list-style-type: none"> • Ordinary glass is not suitable for cooking but may be used for short periods for heating foods. <p>CERAMIC</p> <ul style="list-style-type: none"> • Most ovenproof china, and ceramics, are suited. • Avoid dishes that are decorated with gold or silver leaf. • Avoid using antique pottery. • If unsure, check with the manufacturer.
METAL COOKWARE 	NO	<ul style="list-style-type: none"> • Metal cookware should be avoided when cooking in the microwave oven. • Microwave energy is reflected by metal.
PLASTIC WRAP/ OVEN BAGS (MICROWAVE SAFE ONLY) 	YES	<ul style="list-style-type: none"> • Plastic wrap can be used to cover food. • Some shrinkage of the wrap may occur, over an extended cooking time. • When removing wrap, lift it in such a way to avoid steam burns. • Do not tie oven bags with metal twist ties, substitute with string. • For cooking food with high fat content, do not bring the wrap in contact with the food as it may melt.
ALUMINIUM FOIL 	FOR SHIELDING	<ul style="list-style-type: none"> • Small amounts may be used to shield certain parts of meat and fish when cooking or defrosting. • Remove food in foil trays, if possible, and place in a microwave safe dish. • If not possible, place the foil tray onto a heat proof plate allowing 2.5 cm between the walls of the oven.
STRAW AND WOOD 	NO	<ul style="list-style-type: none"> • Excessive over heating of these materials may cause a fire in the microwave oven.
PAPER 	YES	<ul style="list-style-type: none"> • Paper towels and waxed paper are suitable to use to prevent splatters. • These are suitable for use when reheating foods or for short cooking times.
PLASTIC COOKWARE MICROWAVE SAFE 	YES	<ul style="list-style-type: none"> • Ideal for cooking, reheating and defrosting. • Some microwave safe plastic cookware are not suitable for cooking foods with high fat and sugar content.
BROWNING DISH	YES	<ul style="list-style-type: none"> • Ensure that the preheating time of the dish is not exceeded. • Ensure that a microwave heat proof dinner plate or suitable insulator be placed between the turntable and the browning dish.
THERMOMETERS • MICROWAVE SAFE • CONVENTIONAL	YES NO	

HELPFUL HINTS

1. THE ARRANGEMENT

Arrange foods carefully. Place thickest areas toward outside of dish.



3. COVERING

Cover foods in the microwave if you would normally cover the food in your ordinary oven, or to retain moisture. Cover foods such as Vegetables, Casseroles, or when Reheating.
Use to cover foods:

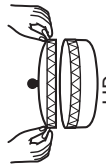

LID



PLASTIC WRAP



PAPER TOWEL

5. SHIELDING

Shield using small pieces of aluminium foil to shield thin areas of meat, fish and poultry or edges of cakes to prevent overcooking.



CHICKEN



FISH

7. STIRRING

Stir foods from the outside to the centre of the dish, once or twice during cooking if possible.

Eg. Casseroles and Sauces.



9. DENSITY

The depth to which microwaves penetrate food varies depending on the food's density. Porous foods like minced beef or mashed potatoes microwave faster than dense ones like steak or whole potatoes.

2. TURNING

Foods such as poultry and joints of meat should be turned over after half the cooking time.

4. PIERCING

Pierce potatoes, eggs, tomatoes or any foods with a skin or membrane to allow steam to escape.



TOMATO



EGG

6. STANDING TIME

Standing time is important. After cooking or defrosting ensure adequate standing time. This allows the food to continue cooking or heating. Refer to cooking guides for each menu or according to manufacturers instructions.

8. SIZE

Small pieces cook faster than large ones. To speed up cooking, cut pieces smaller than 5 cm so microwaves can penetrate to the centre from all sides. For even cooking, make all the pieces the same size.

10. FAT AND BONE

Marbling within meat, or a thin, even layer of fat on a roast, speeds cooking. Large fatty areas or excess drippings in dish attract energy away from meat, and slows cooking. Centre bones do not affect cooking, but bone on the side of meat conducts heat to the areas next to it.

11. STARTING TEMPERATURE

Frozen or refrigerated foods take longer to heat than food at room temperature. Cooking times in this book are based on normal storage temperatures. Since rooms, refrigerators and freezers differ in temperature, check cooking result at the minimum time.



13. CONDENSATION

Condensation is a normal part of microwave cooking. The humidity and moisture in food will influence the amount of condensation in the oven. Generally, covered foods will not cause as much condensation as uncovered foods. Ensure that the ventilation openings are not blocked.

12. QUANTITY

Microwave cooking times are directly related to the amount of food in the oven. Because energy is absorbed by the food itself, one potato or a single piece of chicken cooks rapidly. When the energy is divided among several items, cooking takes more time.

14. GENERAL

Your microwave oven is capable of heating food and beverages very quickly therefore, it is very important that you select the appropriate cooking time and power level for the type and quantity of food to be heated. If you are unsure of the cooking time and power level required, begin with low cooking times and power levels until the food is sufficiently heated evenly throughout.

SHARP