

SENCOR®

SMG 540BK
SMG 640SL



MEAT GRINDER

Translation of the original manual



SENCOR®

**SMG 540BK
SMG 640SL**



A

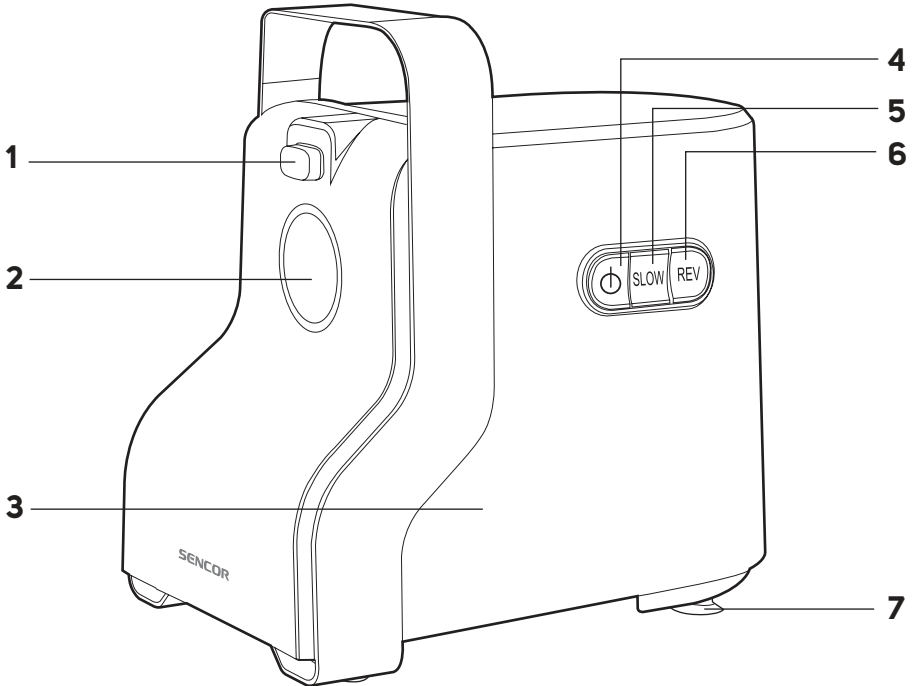

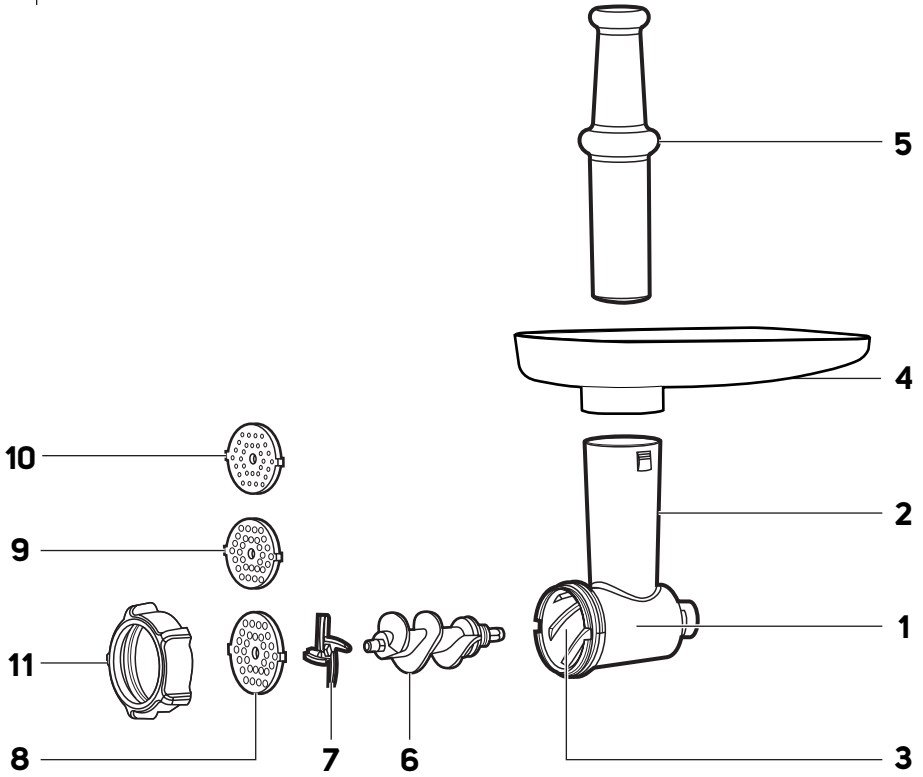
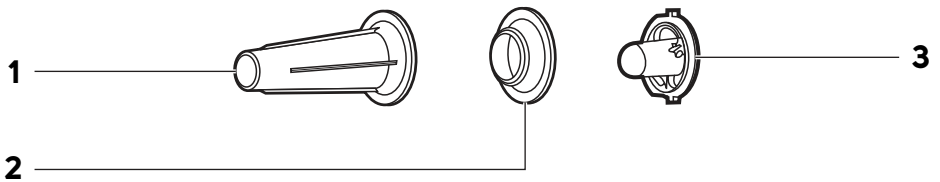
B**C**

D

8

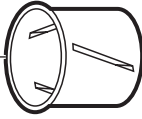

7

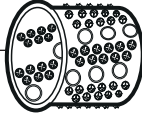

6

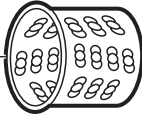

5

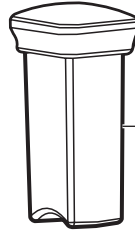
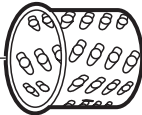

4

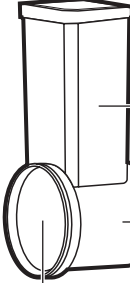

2

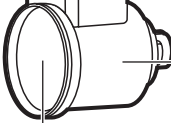

1

3

E

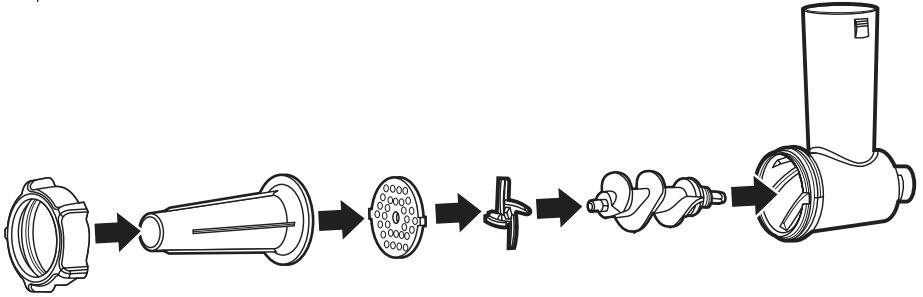
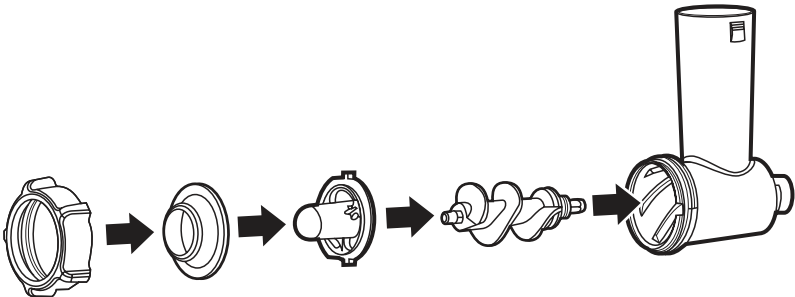

F**G**

EN Meat grinder

Important safety instructions

READ CAREFULLY AND STORE FOR FUTURE USE.

- This appliance may not be used by children. Keep the appliance and its power cord away from children.
- The appliance may be used by persons with reduced physical, sensory or mental capabilities or with a lack of experience and knowledge, if they are supervised or have been instructed to use the appliance in a safe manner and understand the potential dangers.
- Children must not play with the appliance.
- In the event that the power cord is damaged, have it repaired at a professional service centre to prevent causing a dangerous situation. It is forbidden to use the appliance if it has a damaged power cord.
- Incorrect use may result in a risk of injury.
- Pay special attention to the grinding blade, especially when removing and cleaning it. The cutting edges of the grinding blade are sharp and there is risk of serious injury.
- The parts of the appliance and accessories that come into contact with food must be cleaned according to the instructions in this user's manual.
- Always disconnect the appliance from the power supply when leaving it without supervision and before assembly, disassembly or cleaning.

- Before replacing the accessories or accessible parts that move during use, turn the appliance off and disconnect it from the power supply.
- This appliance is designed for household use. This appliance is intended for processing a standard amount of food in the household. Do not use it for other purposes, for which it is not intended.
- Do not use the appliance in an industrial or laboratory environment or outdoors.
- Before connecting this appliance to an electrical power socket, make sure that the voltage stated on its rating label corresponds to the voltage in your power socket. Connect the appliance only to a properly grounded socket. Do not use an extension cord.
- Fully unwind the power cord before use.
- Do not connect and disconnect the appliance's power cord to and from the power socket with wet hands.
- Ensure that the power plug contacts do not come into contact with water or any other liquid. If precisely this happens, carefully dry the power plug before using it again.
- Do not disconnect the appliance from the power socket by pulling on the power cord. This could damage the cord or the el. power socket. Disconnect the power cord from the power socket by pulling on the plug.
- Do not place heavy items on the power cord. Make sure the power cord does not hang over the edge of a table and that it is not touching a hot surface or sharp objects.
- Keep the power cord dry.
- Do not wind the power cord around the appliance.
- Only use the appliance with the original accessories that came with it.
- Before every use, check the selected accessory for damage. Never use the appliance with a damaged accessory.
- Only place the appliance on an even, dry and stable surface.
- Do not place the appliance or its accessories on an electric or gas stove or in its vicinity, on the edge of a table or on an unstable surface.
- Do not place the appliance and its accessories near heaters, open fires or other sources of heat.
- Make sure that the appliance is correctly assembled before putting it into operation.
- Do not touch moving rotating parts during operation. Otherwise, this could result in injury.
- Always adhere to the operating time and the time intended for the cooling down of the appliance prior to it being started again. These times are provided in this user's manual in the relevant chapter.
- Do not use the appliance in continuous operation for longer than 5 minutes. Allow it to cool down for 10 minutes.
- Do not turn on the appliance when it is empty. Incorrect use of the appliance may negatively affect its lifetime.
- Do not use the appliance for crushing bones, nuts or other hard foods. Before using it, remove any bones, skin, cartilage, etc.
- Never process frozen food. Frozen food must be defrosted prior to being processed in the appliance.
- To prevent the appliance from clogging, push down gently on the pusher when adding the food into the feed tube.
- Always use the pusher supplied with the appliance. Never use your fingers or other items to push ingredients through the feed tube while the appliance is running.
- Do not perform any maintenance on the appliance other than cleaning the individual components as described in this user's manual.
- Never use an appliance that is damaged in any way.
- Do not use the appliance if it has fallen on the floor, if it was submerged in water, if it is not functioning correctly or if it is damaged in any other way.
- Always turn off the appliance and disconnect it from the power socket when not using it, when leaving it without supervision and before removing or replacing accessories, and before cleaning, maintenance or storage.
- To prevent the risk of injury by electrical shock, never submerge the motor base unit and its power cord in water or any other liquid, or wash these parts under running water.
- In order to prevent a hazardous situation arising, do not repair the appliance yourself or modify it in any way. Have all repairs performed at an authorised service centre. By tampering with the appliance, you risk voiding your legal rights arising from unsatisfactory performance or quality warranty.

EN Meat grinder

User's manual

- Thank you for purchasing a SENCOR brand product and we hope that you will be happy with it.
- Prior to using this appliance, please read the user's manual thoroughly, even in cases, when one has already familiarised themselves with previous use of similar types of appliances. Only use the appliance in the manner described in this user's manual. Keep this user's manual in a safe place where it can be easily retrieved for future use.
- We recommend saving the original cardboard box, packaging material, purchase receipt and responsibility statement of the vendor or warranty card for at least the duration of the legal liability for unsatisfactory performance or quality. In the event of transportation, we recommend that you pack the appliance in the original box from the manufacturer.



Warning:

No part of this appliance is designed to be washed in a dishwasher!
When cleaning the cross blade and the graters, be very careful not to injure yourself on their sharp edges.



Warning:

Do not rinse the motor base unit or its power cord under water or submerge it in water. Prevent water from entering into the buttons.

DESCRIPTION OF THE APPLIANCE

- | | |
|---|--|
| A1 Grinder or grating attachment lock/release button | A4 On/Off button |
| A2 Hole for mounting the grinder or the grating attachment | A5 SLOW button (slow rotation) |
| A3 Motor base unit | A6 REV button (reverse rotation) |
| | A7 Anti-slip feet |

DESCRIPTION OF ACCESSORIES – MEAT GRINDER

- | | |
|----------------------------|--------------------------------------|
| B1 Grinder | B7 Cross blade |
| B2 Feed tube | B8 Coarse grinding plate |
| B3 Grinding chamber | B9 Fine grinding plate |
| B4 Feeder tray | B10 Extra fine grinding plate |
| B5 Pusher | B11 Screw ring |
| B6 Screw shaft | |

DESCRIPTION OF ACCESSORIES – SAUSAGE STUFFER ATTACHMENT

- | | |
|--|-------------------------------------|
| C1 Sausage stuffer attachment | C3 Shaper (for making Kebbe) |
| C2 Separator (for making Kebbe) | |

DESCRIPTION OF ACCESSORIES – GRATER ATTACHMENT

- | | |
|-------------------------------------|---|
| D1 Grater attachment | D6 Grater for fine grating |
| D2 Feed tube | D7 Grater for hard cheese and nuts |
| D3 Chamber | D8 Grater for making slices |
| D4 Pusher | |
| D5 Grater for coarse grating | |

PURPOSE OF USE

- The grinder is intended for processing meat, poultry, fish, fruits and vegetables. Enables the grinding of all types of meats free of bones, sinew and skin.
- The grating attachment can be used for chopping, peeling, grating and slicing practically all types of fruits and vegetables. The grating attachments are used for the processing of fruit, vegetables, cheese and similar types of food.

BEFORE FIRST USE

- Before first use, take the appliance and its accessories out of the packaging material and remove all promotional labels and stickers. Check that neither the appliance nor any of its parts is damaged.
- Before first use, wash all parts that come into contact with food in hot water using neutral dishwashing detergent. Then rinse these parts with clean water and allow them to dry naturally or dry them out their using a wiping cloth.

LOCATION

- Place the motor base unit on an even, dry, clean and stable surface within reach of a power socket.
- Ensure that there is sufficient free work space around the motor base unit.

ASSEMBLY

Meat grinder (fig. E)

1. Push and hold down the grinder lock/release button and place the grinder against the hole in the motor base unit.
2. Tilt the grinder to the right (at an angle of approx. 45°) and insert it into the hole.
3. Turn the grinder anti-clockwise to secure it in place.
4. Release the grinder lock/release button.
5. Insert the screw shaft into the grinding chamber. Rotate it slightly so that it slides into the holes in the motor base unit.
6. Put the cross blade on to the screw shaft so that the cutting edge faces forwards.
7. Attach the required grinding plate so that the notch in the grinding chamber slides into the groove in the grinding plate.
8. Finally, screw on the screw ring and tighten it firmly.
9. Insert the tray into the feed tube.

Grinder for stuffing sausages (fig. F)

1. Assemble the grinder according to steps 1–7 as described in the section "**Meat grinder**".
2. Place the sausage stuffer attachment on to the grinding plate.
3. Finally, screw on the screw ring and tighten it firmly.
4. Insert the tray into the feed tube.

Grinder for making kebbe (fig. G)

1. Assemble the grinder according to steps 1–5 as described in the section "**Meat grinder**".
2. Put the shaper on to the screw shaft and then the separator.
3. Finally, screw on the screw ring and tighten it firmly.
4. Insert the tray into the feed tube.

Grinder with the grating attachment

1. Push and hold down the lock/release button and place the grating attachment against the hole in the motor base unit.
2. Tilt the grating attachment to the right (at an angle of approx. 45°) and insert it into the hole.
3. Turn the attachment anti-clockwise to secure it in place.
4. Release the lock/release button.
5. Depending on the preferred grating fineness, select a grater and insert it into the grating chamber of the attachment. Turn the grater clockwise to lock it in the chamber.
6. Insert the pusher into the feed tube of the attachment.

**Warning:**

When handling the cross blade or the graters, be very careful not to injure yourself on their cutting edges.

OPERATION

- Check that the grater is correctly assembled.
- Place the ingredients that you wish to process on to the feeder tray.

**Warning:**

Never attempt to grind frozen meat or other types of frozen food, meat with bones, cartilage, sinewy pieces of meat, pits, fruit stones, nuts in shells, etc. It is necessary to allow frozen food to defrost completely before grinding it.

- Underneath the grinder, place an appropriate bowl or plate, into which the processed food will fall.
- Insert the power plug into a power socket.
- Turn on the grinder using the On/Off button and the grinder will start running.
- Gradually place the food into the feed tube, and using the pusher, push it down into the grinding chamber. To prevent the grinder from clogging, do not overfill the feed tube. Push down gently on the pusher.

**Warning:**

Never use fingers or other items to push the ingredients in. For this, always use the provided pusher.

- In the event that the feed tube becomes clogged, first turn off the grinder using the On/Off button and attempt to release it using reverse rotation. If reverse rotation does not release the grinder, disconnect it from the power socket, take the grinder off the base unit and clean it out. If necessary, completely disassemble the grinder, clean it out and reassemble it. Mount it back on to the motor base unit and continue working.

**Warning:**

The maximum continuous operating time of the appliance is 5 minutes. Then allow it to cool down for approximately 10 minutes.

- When you have finished using it, stop the base unit using the On/Off button and disconnect the power cord from the power socket. Ensure that the rotating parts have stopped rotating, take the grinder off the motor unit base and disassemble it into its individual parts. Then clean all used parts according to the instructions in chapter "CLEANING AND MAINTENANCE".

REVERSE ROTATION

- In the event that the grinder behaves in an unusual manner (e.g. it is noisier or vibrating, the grinding chamber is clogged), turn it off by pressing the On/Off button.
- Then press the **REV** button (reverse rotation). The screw shaft will start rotating in reverse direction and the grinding chamber will start emptying itself.
- If this does not happen, disconnect the base unit from the power socket, completely disassemble the grinder, clean it out and reassemble it. Mount it back on to the motor base unit and continue working.

SLOW ROTATION

- Press the **SLOW** button to start the slow rotation. The screw shaft will rotate at a lower speed than during normal operation.
- The lower speed is suitable, e.g. for stuffing sausages and making kebabs.

TIPS AND ADVICE**Grinding**

- Before grinding, remove any bones, cartilage and tendons from the meat. Cut the meat into pieces measuring approximately 20 x 20 x 40 mm. Allow the meat to defrost completely before any further processing.
- Cut fruit and vegetables into pieces that will freely pass through the feed tube. Peel fruit or vegetables as required and remove any stones, kernels, etc.

Stuffing sausages

- Prepare a ground meat mixture and a casing for stuffing. Place the casing into lukewarm water for 10 minutes before filling it. Slide the wet casing on to the attachment. Leave a few free centimetres at the end of the casing and then tie it or skewer it.

Grating

- Cut the food into pieces that will freely pass through the feed tube. Peel fruit or vegetables as required and remove any stones, kernels, etc.

DISASSEMBLING

- Check that the grinder is turned off and the power cord plug is disconnected from the power socket.
- Press and hold the lock/release button.
- Turn the grinder/attachment clockwise to an angle of approximately 45° and slide it off the hole of the motor base unit.
- Release the lock/release button.

CLEANING AND MAINTENANCE

- The grinder must be cleaned after every use.
- Disconnect the power plug from the power socket and allow the appliance to cool down before cleaning it.
- For cleaning, do not use cleaning products with an abrasive effect, solvents, etc. that could damage the appliance. No part of this appliance is intended for washing in a dishwasher.

**Warning:**

To prevent the risk of injury by electrical shock, do not submerge the appliance, power cord or power plug in water or any another liquid.

Grinder/grating attachment

- Disassemble the grinder or the grating attachment into its individual parts. Clean the all the removed parts from food remains, wash in warm water with dish washing detergent and rinse under clean running water. Then allow them to dry naturally or dry them out thoroughly using a wiping cloth.
- Remains of unground meat may remain in the grinding chamber that are hard to clean away. To make their removal easier, you can grind a piece of bread or bread roll. We recommend disassembling the grinding attachment in a kitchen sink or a larger bowl to prevent potentially soiling the work surface. If the grinder or the grating attachment is used for an extended period of time, it is possible that the base unit may be hot to touch. Allow it to cool down before cleaning it.



Warning:

No part of this appliance is designed to be washed in a dishwasher!
When cleaning the cross blade and the graters, be very careful not to injure yourself on their sharp edges.

Motor base unit

- Wipe the motor base and the hole for mounting the grinder or grating attachment using a dry wiping cloth.

Storage

- When not using the appliance for an extended period of time, disconnect the power plug from the power socket, allow the appliance to cool down and clean it according to the instructions in chapter "Cleaning and maintenance".
- Before storing it, check that the appliance and all its accessories are thoroughly clean and dry.
- Store the appliance in a dry, clean and well-ventilated location not exposed to extreme temperatures and out of children's reach.

TECHNICAL SPECIFICATIONS

| | |
|--------------------------|------------------------|
| Rated voltage range..... | 220–240 V~ |
| Rated frequency..... | 50–60 Hz |
| Rated power input..... | 700 W |
| Maximum power input..... | 2100 W |
| Capacity | 100 kg/h (SMG 5400BK) |
| | 130 kg/h (SMG 6400SL) |
| Noise level..... | 92 dB(A) (SMG 5400BK) |
| | 93 dB (A) (SMG 6400SL) |

The declared noise emission level of the appliance is 92 dB(A) (SMG 5400BK); 93 dB (A) (SMG 6400SL), which represents a level A of acoustic power with respect to a reference acoustic power of 1 pW.

Safety class for electrical shock protection:



Class II – Electrical shock protection is provided by double or heavy-duty insulation.

We reserve the right to change text and technical specifications.

INSTRUCTIONS AND INFORMATION REGARDING THE DISPOSAL OF USED PACKAGING MATERIALS

Dispose of used packaging material at a site designated for waste in your municipality.

DISPOSAL OF USED ELECTRICAL AND ELECTRONIC EQUIPMENT



This symbol on products or original documents means that used electric or electronic products must not be added to ordinary municipal waste. For proper disposal, renewal and recycling, hand these products over at determined collection points. Alternatively, in some European Union states or other European countries you may return your products to the local retailer when buying an equivalent new product. Correct disposal of this product helps save

valuable natural resources and prevents potential negative effects on the environment and human health, which could result from improper waste disposal. Ask your local authorities or collection facility for more details. In accordance with national regulations penalties may be imposed for the incorrect disposal of this type of waste.

For business entities in European Union states

If you want to dispose of electrical or electronic equipment, ask your retailer or supplier for the necessary information.

Disposal in other countries outside the European Union.

This symbol is valid in the European Union. If you wish to dispose of this product, request the necessary information about the correct disposal method from the local council or from your retailer.



This product meets all the basic requirements of EU directives related to it.



FAST ČR, a.s.
U Sanitasu 1621
CZ-251 01 Říčany
www.sencor.eu